

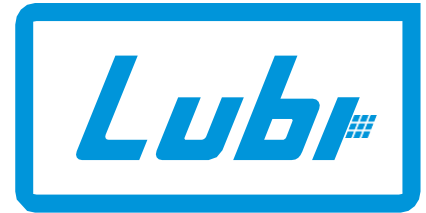

Self-Priming Mud Pumps
50 Hz



PUMPS • MOTORS
ISO 9001 Company



Pumping Solution

Available with Your Trusted Partner for Water Treatment Solutions:



Product data

Introduction	3
Applications	3
Features and benefits	3
Operating conditions	4
Pumped liquids	4
Pump location	4
Curve conditions	4
Motor	4

Construction

Sectional drawing (Close coupled with motor)	5
Sectional drawing (Bare pump)	6

Performance curves/

Technical data

LBM 110, 310, 320	7
LBM 130, 330	8
LBM 355	9
LBM 10, 20, 410	10
LBM 30, 430	11
LBM 55, 50, 70, 455	12
LBM 105, 4105, 125	13
LBM 56, 75, 106	14
LBM 205, 255	15

Introduction

The Lubi **LBM** series are self-priming, horizontal, single-stage, centrifugal, end-suction pumps.

Pumps are available from 0.75 to 2.2 kW in single-phase and from 0.75 to 7.5 kW in three-phase power supply.

Motor and pump are close coupled in a convenient and compact design for quick installation in limited space. They are also available as bare pump unit which are suitable for coupling with motor / engine.

The pump is fitted with a gland packing and single piece pump-motor shaft (in close coupled version). Mechanical shaft seal is available in 0.75 kW models.

The pumps have suction port above pump axis and radial discharge port.

The pumps have non-clogging open type impeller which can handle liquids with solids up to 20 mm grain size.

The pumps are engineered to draw from liquid sources below ground level or from sources which have no positive pressure to naturally prime the pump.

These pumps are inherently designed to allow the pump to re-prime itself typically under lift conditions. Only first time priming is required to remove the air from system.

The pump will re-prime itself even if partially filled with liquid and with completely empty suction pipe.

These pumps are very effective to eliminate the need for foot valves, vacuum and ejector pumps which can become clogged or be impractical to use for prolonged or remote operation.

Applications

Industries: Petrochemical, fertilizers, pharmaceutical, dyes & intermediate industries, effluent treatment plants, food processing plants, sewage plants, starch, paper, sugar plants, thermic fluid circulations, fatty acid distillation plants.

Public utilities: For pumping muddy water, sewage and polluted liquids, dewatering of swimming pools.

Civil engineering: Flood drainage, sewage pumping, fire fighting, dewatering of canals and ponds.

Construction industries: Dewatering of excavation, small pits, basements, trenches, construction sites.

Marine: Loading and unloading, dewatering of docks & vessels, bilge pumping.

Waste treatment: Pumping polluted, hot or corrosive waste water containing sand, mud or solids, in suspension, dosing neutralizing liquid, pumping out settled sludge.

Agriculture: Surface irrigation, liquid manure oxygenation, distribution of liquid animal feed, washing.

Any other applications where priming is to be avoided.

Features and benefits

Following are the main features and benefits offered by the LBM pumps.

Excellent quick automatic pumping action without foot valve up to 8 metres at mean sea level

Compact design

Easy and simple installation

User-friendly operation

Low noise level

Reliable and robust construction

Reliable water supply

Back pull-out design which simplifies inspection and maintenance

Rotating parts are dynamically balanced which ensure vibration free performance and enhanced life

Better efficiency due to good hydraulic design

Automatic air release during priming

Can withstand wide voltage fluctuations

Class-F motor insulation which can handle higher motor temperature

Thermally protected motors which prevents motor from burn out

Non-clogging impeller flow design which can handle suspended solids up to 20 mm

Construction: Bare pump/Motor coupled/Engine-coupled.

Operating conditions

Flow range	: Up to 305 m ³ /h
Head range	: Up to 37 metres
Ambient temperature	: Max. +50°C
Liquid temperature range:	0°C to +90°C
Total suction lift	: Up to 8 metres

Pumped liquids

These pumps are designed for liquids which are non-aggressive and non-explosive, muddy water, with or without solids up to 20 mm grain size or fibres.

Pump location

The pumps have been designed to operate in a non-aggressive and non-explosive atmosphere.

The relative humidity should not exceed 95%.

Curve conditions

The conditions below apply to the curves shown the following pages.

Tolerances in accordance with ISO 9906, Annex A.

The motors used for the measurement are standard motors.

Test results with clean cold water, without gas content. Measurements have been made with airless water at a temperature of 20°C.

Head and power values valid for liquids with density = 1.0 kg/dm³ & kinematic viscosity = max 1 mm²/s (1 cSt).

The QH curves apply to a rated motor speed of 2900 min⁻¹ or 1450 min⁻¹ as mentioned on the performance curves.

Motor

The pump is fitted with a Totally Enclosed Fan Cooled, 2-pole or 4-pole induction motors which performance comply with IS:325.

Ratings	: 1 phase - 0.75 to 2.2 kW 3 phase - 0.75 to 18.5 kW
Rated speed	: 2900, 1450 rpm
Enclosure class	: IP 55
Insulation class	: F
Standard voltages	: 1 phase, 230 V (Tolerance +5% / -15%) 3 phase, 400 V
Supply frequency	: 50 Hz
Duty / Rating	: S1 / Continuous
Direction of rotation	: Clockwise as seen from the motor rear end (LBM 110, 310, 320, 130, 330, 10, 20, 30, 50, 70, 56, 75, 106) Anti-clockwise as seen from the motor rear end (LBM 355, 55, 105).

Single-phase motors have built-in thermal overload protection.

Three-phase motors must be connected to a motor starter according to local regulations.

Sectional drawing (Close coupled with motor)

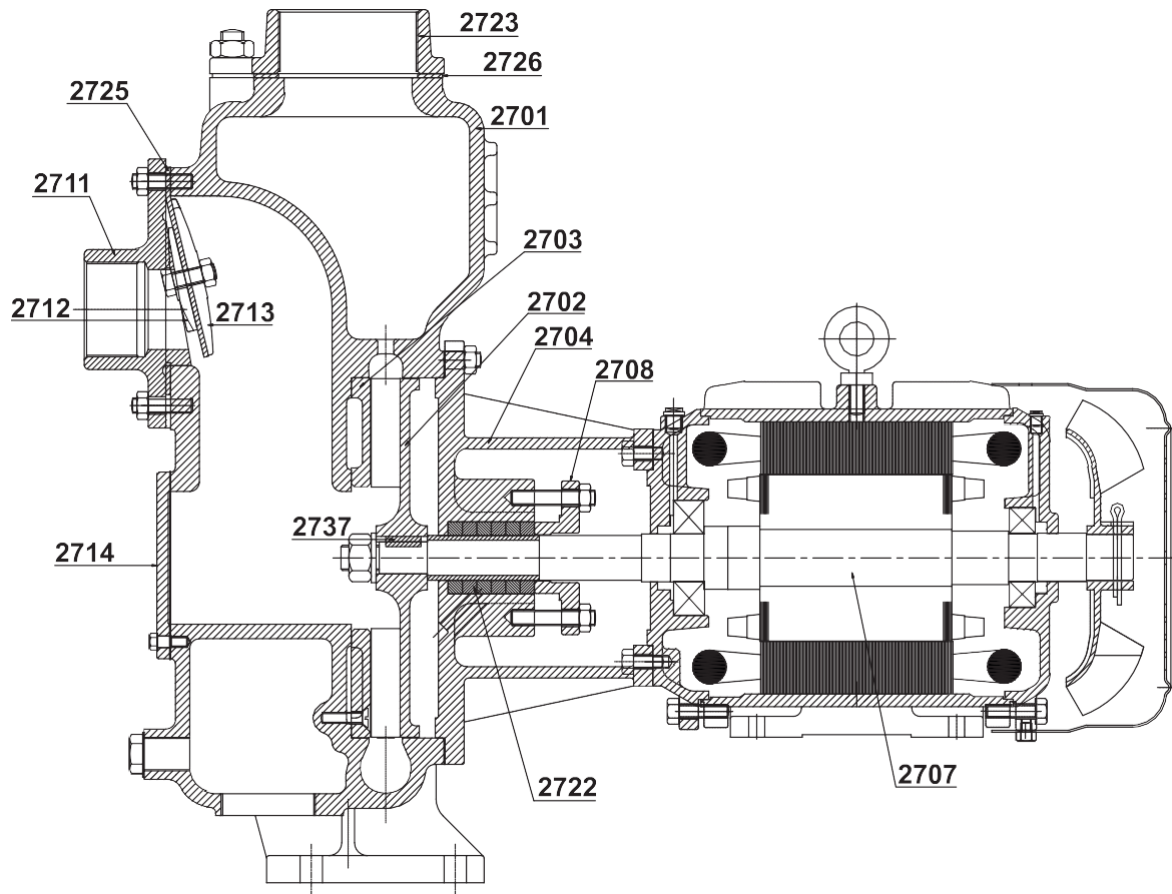

Materials

Pos.	Component	Material	Pos.	Component	Material
2701	Volute	Cast iron	2713	Front support pad	Cast iron
2702	Impeller	Cast iron	2714	Cover	Cast iron
2703	Volute ring	Cast iron	2722	Sleeve	S.S AISI 410/Bronze
2704	Adaptor	Cast iron	2723	Flange	Cast iron
2707	Shaft	Carbon steel	2725	Rubber packing	Rubber
2708	Gland	Cast iron	2726	Rubber packing	Rubber
2711	Suction flange	Cast iron	2737	Key	Carbon steel
2712	Back support pad	Cast iron			

Sectional drawing (Bare pump)

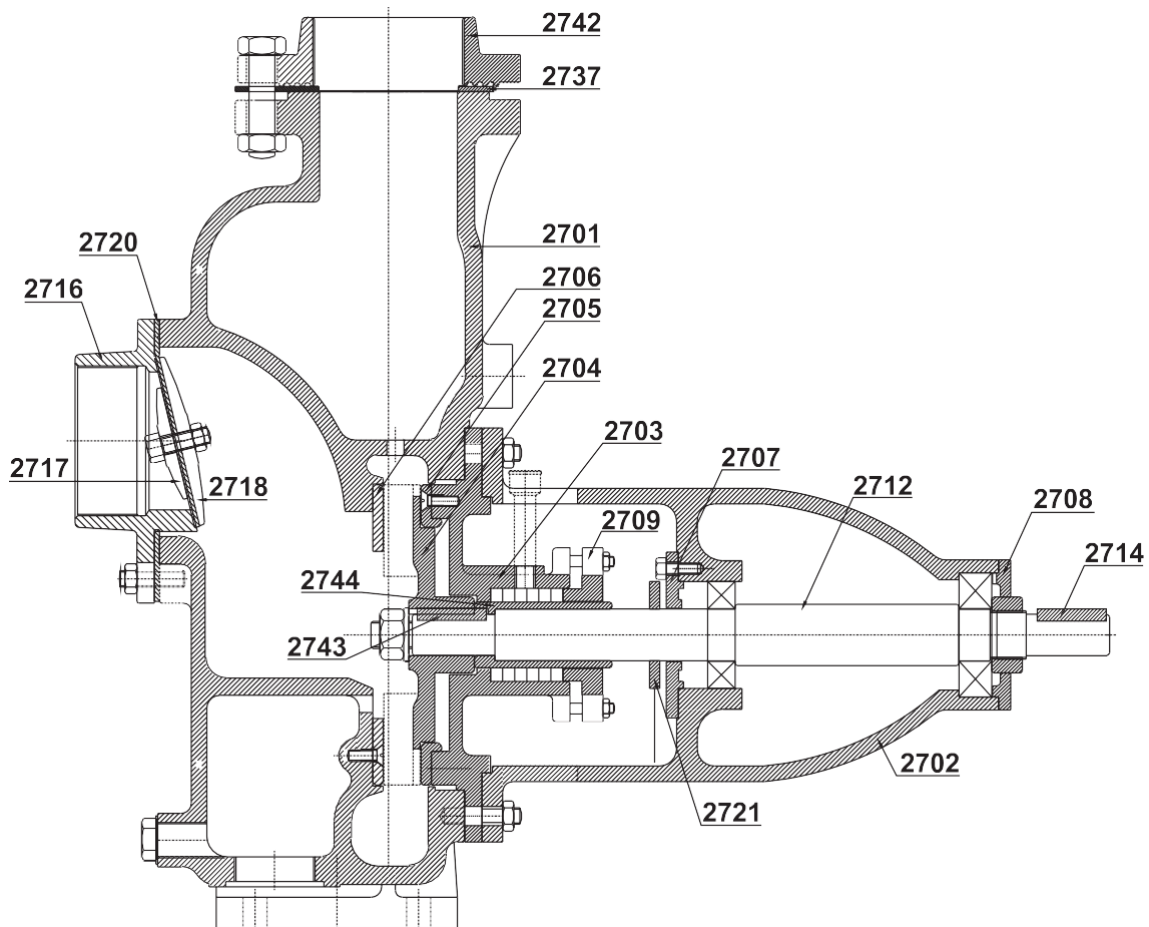

Materials

Pos.	Component	Material	Pos.	Component	Material
2701	Volute	Cast iron	2714	Key	Carbon steel
2702	Adaptor	Cast iron	2716	Suction flange	Cast iron
2703	Back plate	Cast iron	2717	Back support pad	Cast iron
2704	Impeller	Cast iron	2718	Front support pad	Cast iron
2705	Back plate ring	Cast iron	2720	Rubber packing	Rubber
2706	Volute ring	Cast iron	2721	Water thrower	Rubber
2707	Bearing cover	Cast iron	2737	Rubber packing	Rubber
2708	Bearing cover	Cast iron	2742	Square flange	Cast iron
2709	Gland	Cast iron	2743	Key	Carbon steel
2712	Shaft	Carbon steel	2744	Sleeve	S.S AISI 410/Bronze

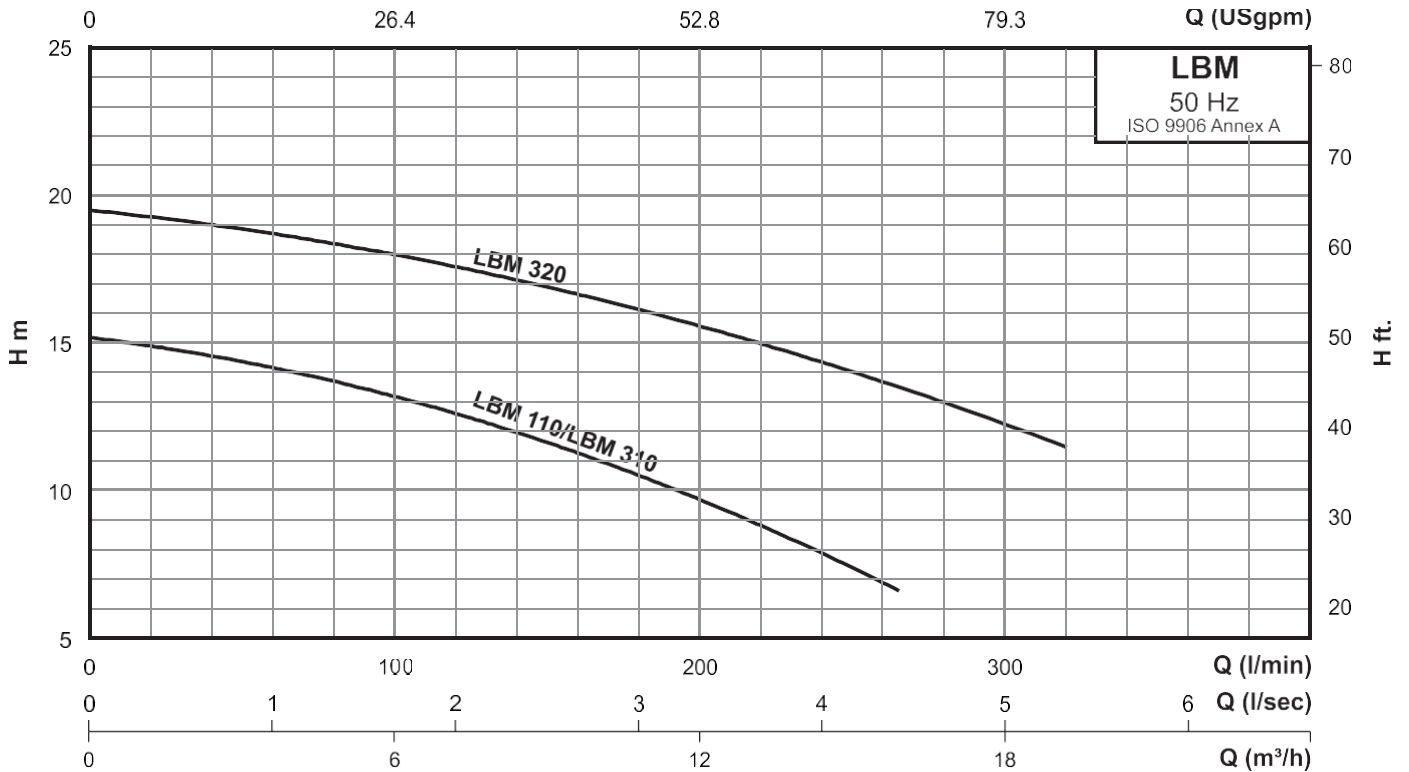

Performance data at n = 2900 rpm

Model		Power		Q m³/h	6	9	12	15	18
Single-phase	Three-phase	[kW]	[HP]	Q l/min	100	150	200	250	300
LBM 110	LBM 310	0.75	1.00	H	13.2	11.6	9.7	7.5	-
-	LBM 320	1.50	2.00	mts.	18	16.9	15.5	14	12.2

Dimensional sketches

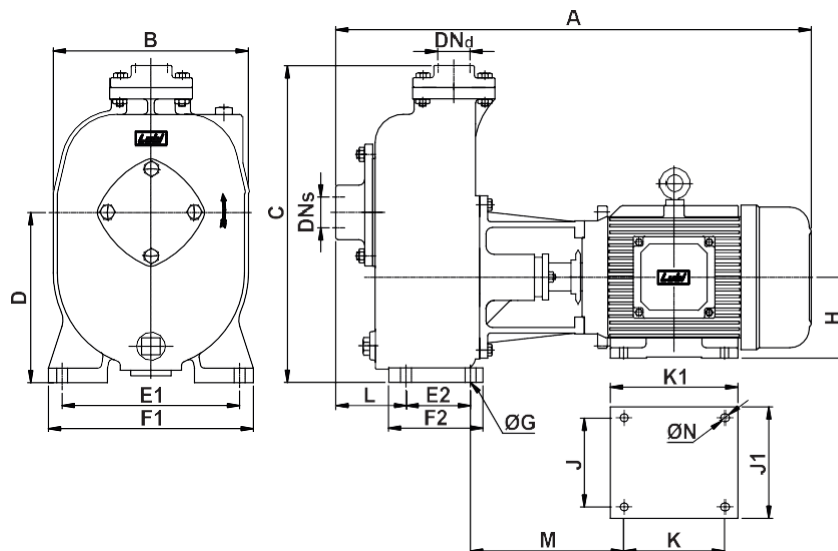

Dimensions & weights

Model		Power		DNs	DNd	Dimensions [mm]															Gross weight [kg]	Gross volume [m³]			
Single-phase	Three-phase	[kW]	[HP]			A	B	C	D	E1	E2	F1	F2	ØG	L	M	K	K1	J	J1	H	ØN			
LBM 110	LBM 310	0.75	1.00	1½"	1½"	466	189	353	206	110	-	142	89	11	213	-	-	-	-	-	-	-	-	60.0	0.130
-	LBM 320	1.50	2.00	1½"	1½"	590	242	395	211	220	80	254	118	14	91	192	125	158	140	168	90	10	91.0	0.230	

Note: All dimensions in mm unless otherwise noted.

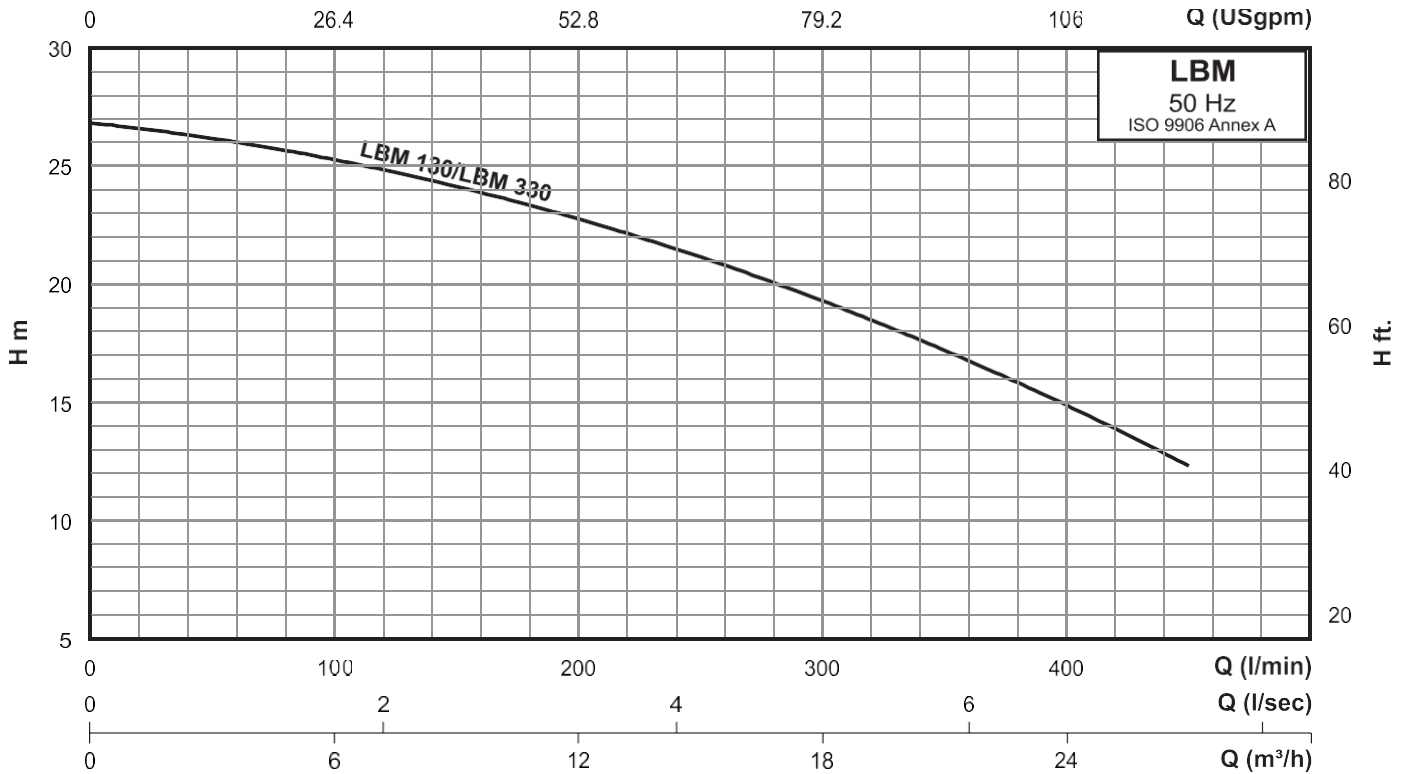

Performance data at n = 2900 rpm

Model		Power		Q m³/h	6	12	18	24	27
Single-phase	Three-phase	[kW]	[HP]	Q l/min	100	200	300	400	450
LBM 130	LBM 330	2.20	3.00	H mts.	25.3	22.9	19.4	15	12.5

Dimensional sketches

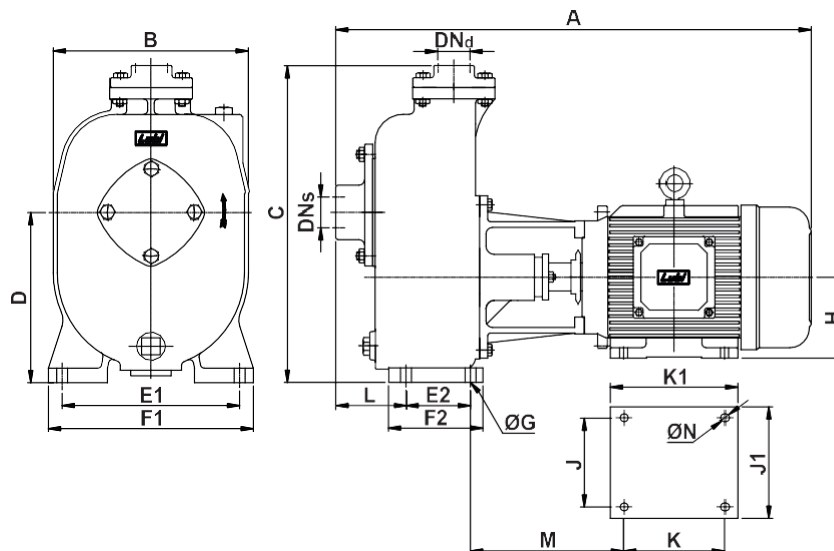

Dimensions & weights

Model		Power		DN _s	DN _d	Dimensions [mm]																Gross weight [kg]	Gross volume [m³]	
Single-phase	Three-phase	[kW]	[HP]			A	B	C	D	E1	E2	F1	F2	ØG	L	M	K	K1	J	J1	H	ØN		
-	LBM 330	2.20	3.00	2"	2"	631	250	428	210	220	80	258	118	14	98	205	140	170	160	195	100	12	102.0	0.230
LBM 130	-	2.20	3.00	2"	2"	631	250	428	210	220	80	258	118	14	98	210	140	180	190	230	112	12	102.0	0.230

Note: All dimensions in mm unless otherwise noted.

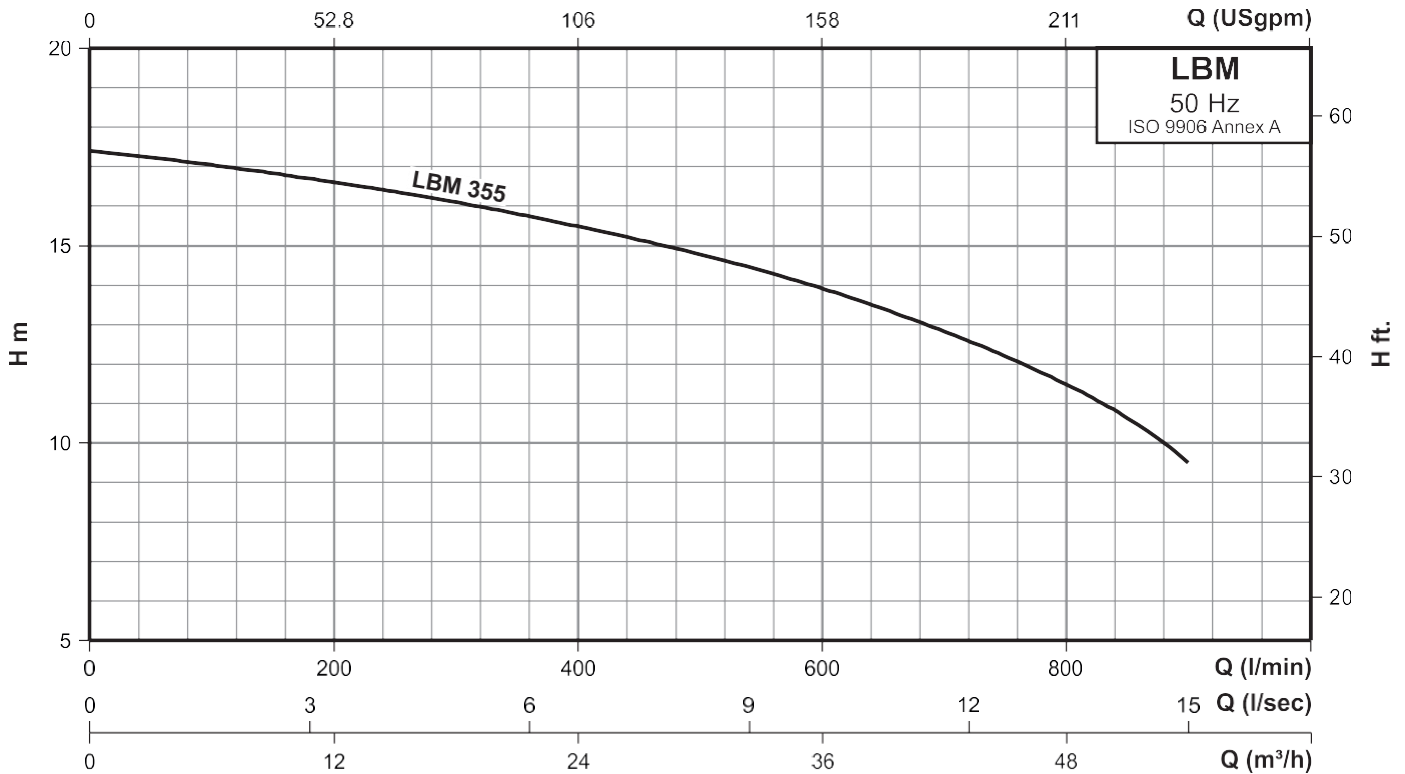

Performance data at n = 1450 rpm

Model	Power		Q m³/h	12	24	36	48	54
	[kW]	[HP]						
Three-phase			Q l/min	200	400	600	800	900
LBM 355	3.70	5.00	H mts.	16.5	15.5	14	11.5	9.5

Dimensional sketches

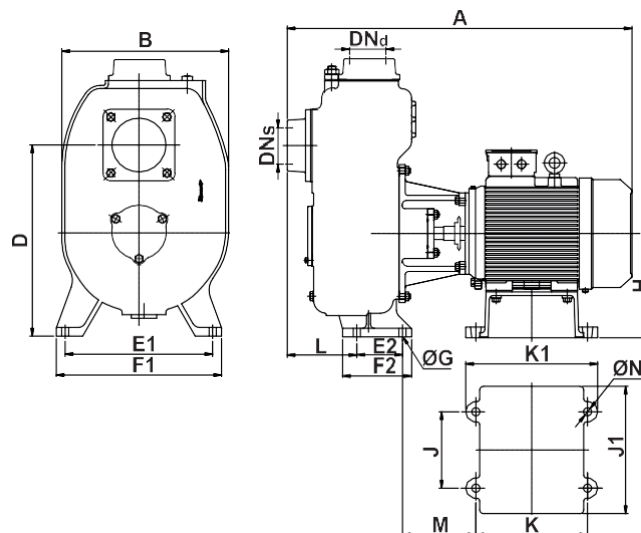

Dimensions & weights

Model	Power		DN _s	DN _d	Dimensions [mm]																Gross weight [kg]	Gross volume [m³]	
	[kW]	[HP]			A	B	C	D	E1	E2	F1	F2	ØG	L	M	K	K1	J	J1	H			ØN
LBM 355	3.70	5.00	3"	3"	679	328	546	376	290	90	325	136	14	137	144	220	260	150	250	205	16	169.0	0.345

Note: All dimensions in mm unless otherwise noted.

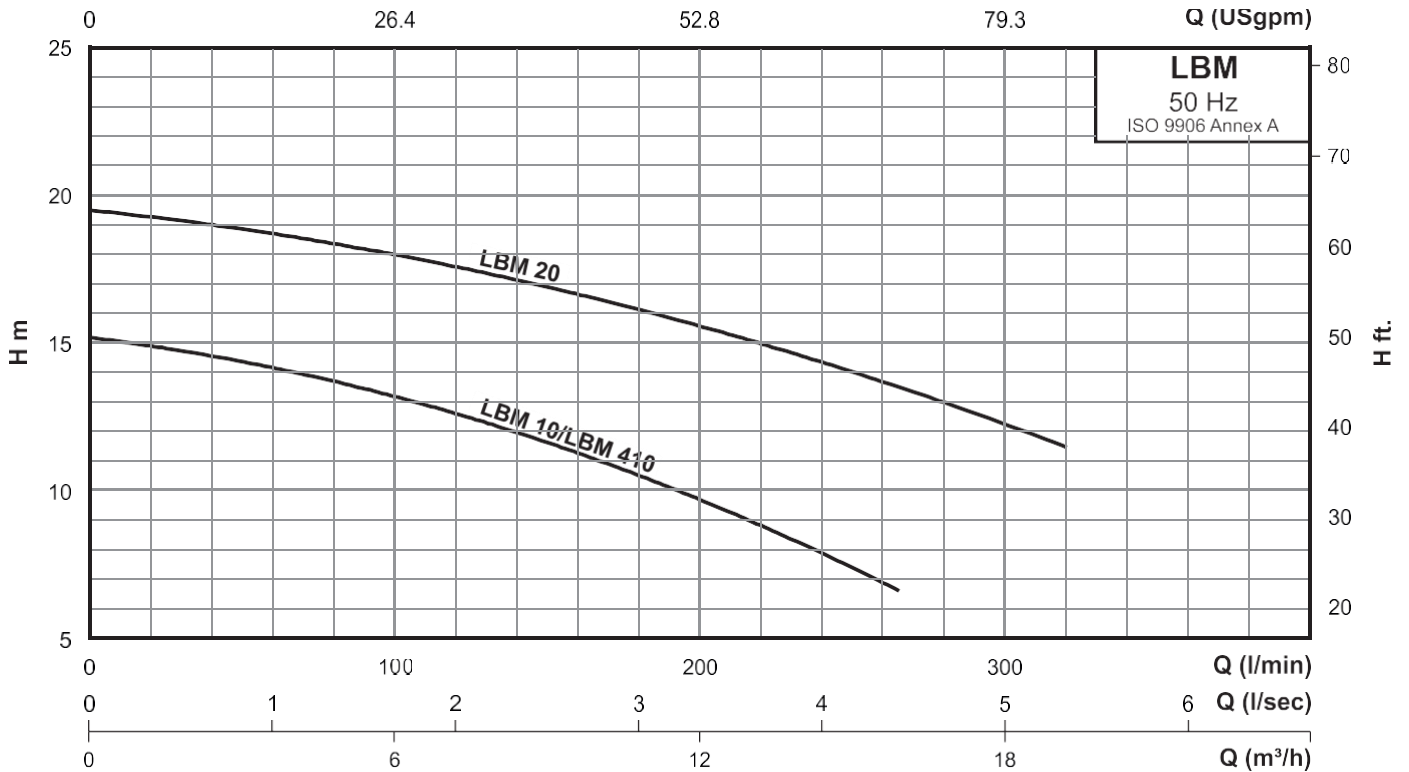

Performance data at n = 2900 rpm

Model	Power		Q m³/h	6	9	12	15	18
	[kW]	[HP]						
LBM 10/LBM 410	0.75	1.00	Q l/min	100	150	200	250	300
LBM 20	1.50	2.00	H mts.	13.2	11.6	9.7	7.4	-
				18	16.9	15.5	14	12.2

Dimensional sketches

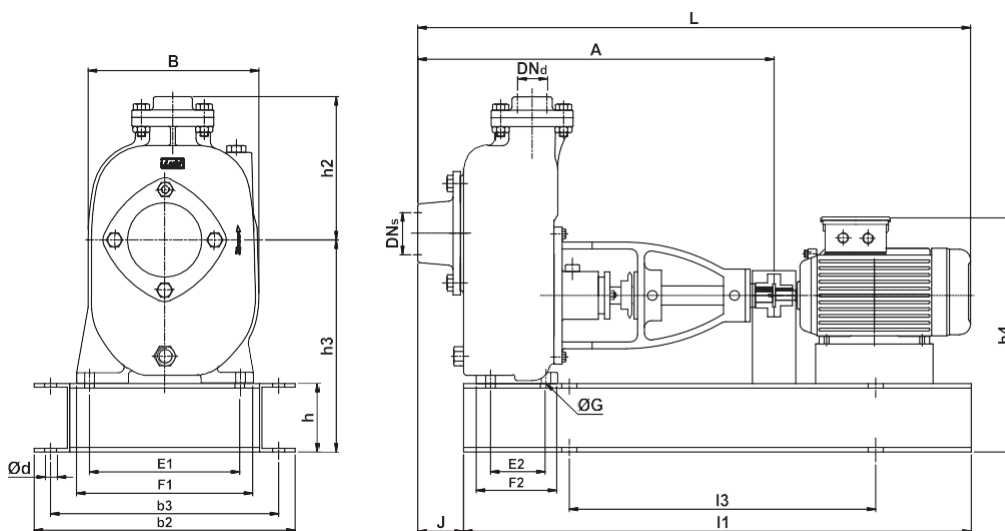

Dimensions & weights

Model	Power		DNs	DNd	Dimensions [mm]																Gross weight [kg]	Gross volume [m³]		
	[kW]	[HP]			A	B	E1	E2	F1	F2	ØG	J	h2	L	I1	I3	b2	b3	Ød	h			h3	h4
LBM 10	0.75	1.00	1½"	1½"	436	189	103	133	145	197	11	59	149	729	598	448	265	222	22	100	306	295	127.0	0.221
LBM 20	1.50	2.00	1½"	1½"	526	242	220	80	254	117	14	53	183	848	722	572	374	324	22	100	311	324	148.0	0.337

Note: All dimensions in mm unless otherwise noted.
LBM 410 is diesel engine driven pumpset.

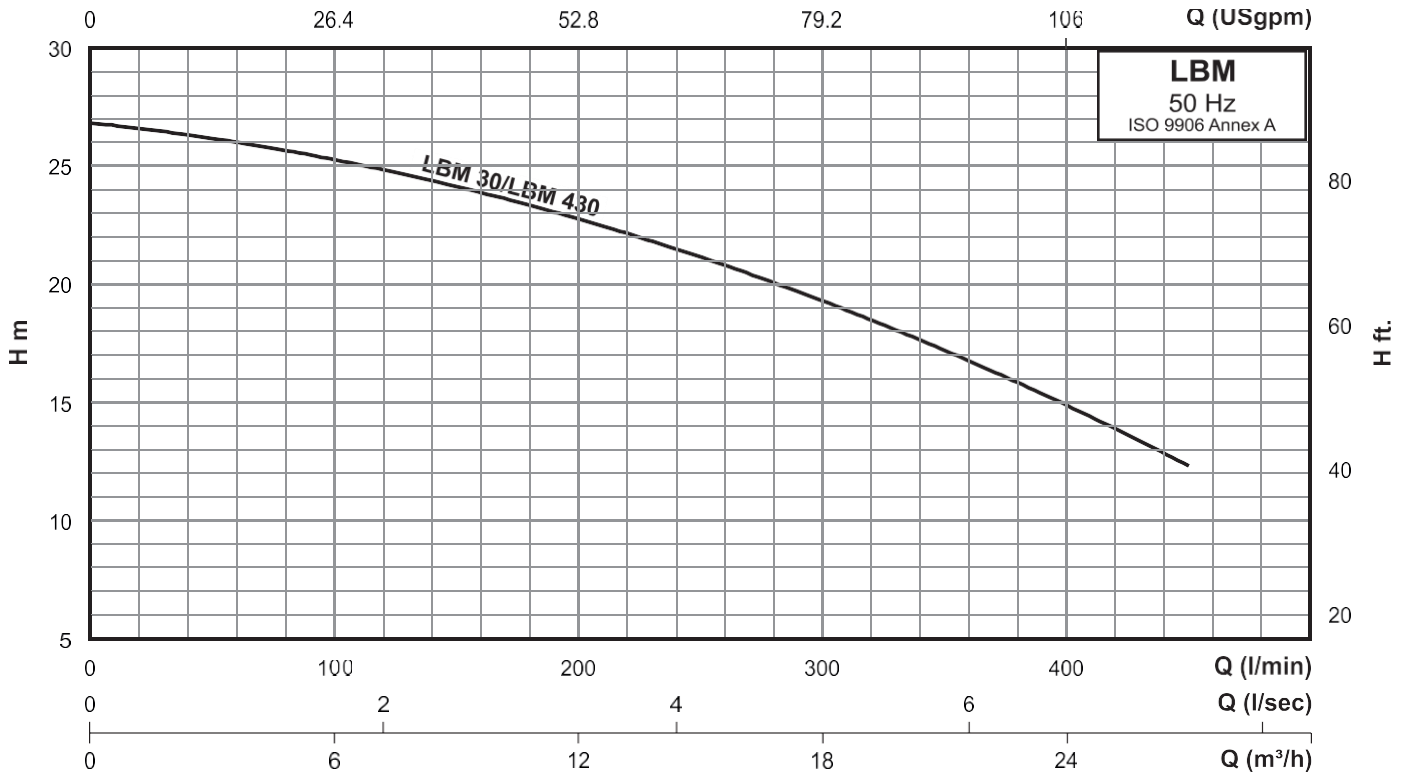

Performance data at n = 2900 rpm

Model	Power		Q m³/h	6	12	18	24	27
	[kW]	[HP]	Q l/min	100	200	300	400	450
LBM 30/LBM 430	2.20	3.00	H mts.	25.3	22.9	19.4	15	12.5

Dimensional sketches

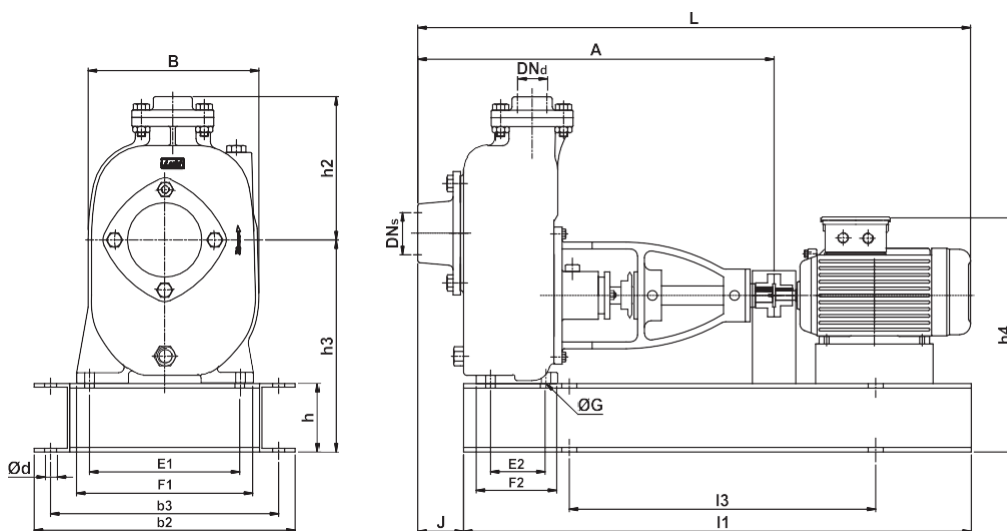

Dimensions & weights

Model	Power		DNs	DNd	Dimensions [mm]																Gross weight [kg]	Gross volume [m³]		
	[kW]	[HP]			A	B	E1	E2	F1	F2	ØG	J	h2	L	I1	I3	b2	b3	Ød	h			h3	h4
LBM 30	2.20	3.00	2"	2"	537	250	220	80	258	118	14	58.5	219	874	741	591	378	328	22	100	310	323	167.0	0.367

Note: All dimensions in mm unless otherwise noted.
LBM 430 is diesel engine driven pumpset.

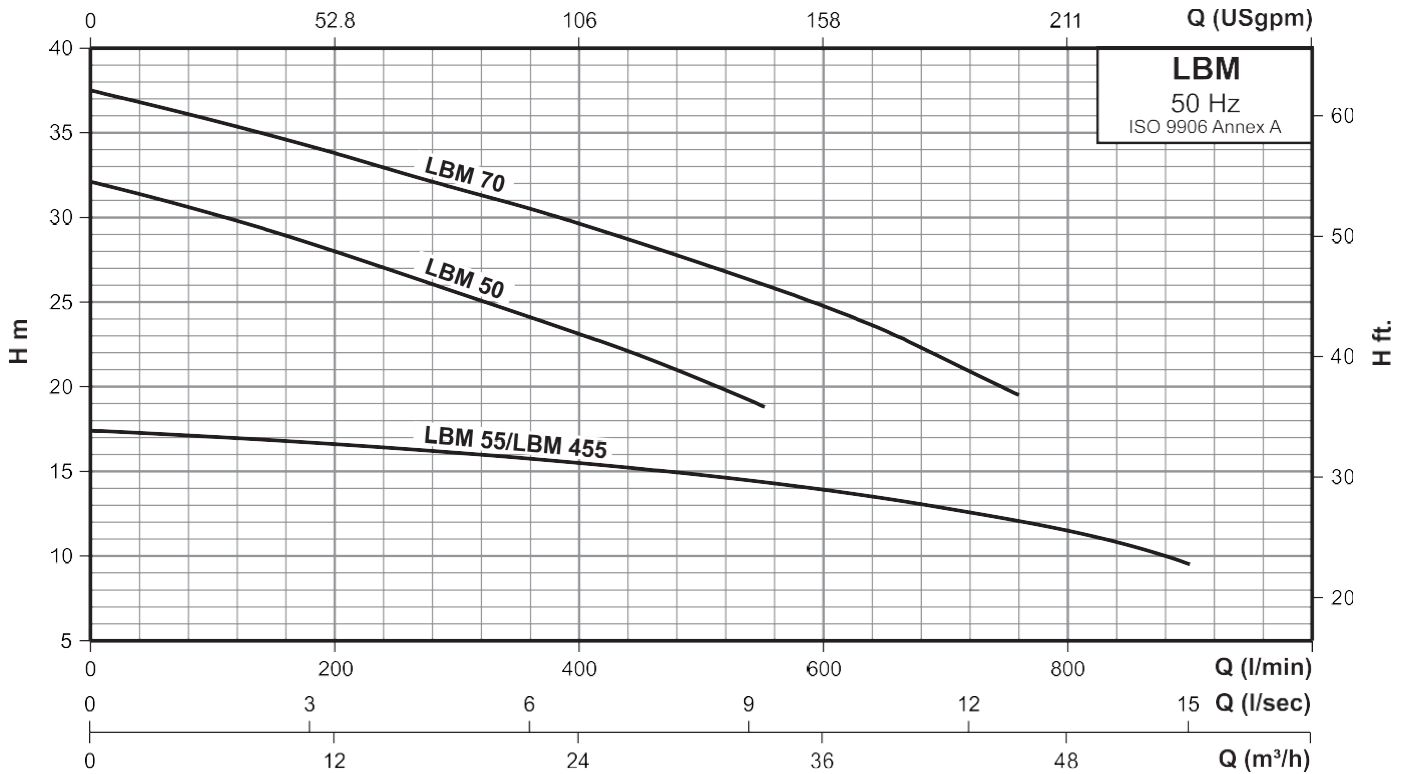

Performance data at n = 2900 rpm for LBM 50, LBM 70 and n = 1450 rpm for LBM 55

Model	Power		Q m³/h	12	24	36	48	54
	[kW]	[HP]						
LBM 55/LBM 455	3.70	5.00	Q l/min	200	400	600	800	900
LBM 50	3.70	5.00	H mts.	16.5	15.5	14	11.5	9.5
LBM 70	5.50	7.50		28	23	-	-	-
				33.8	29.7	24.8	-	-

Dimensional sketches

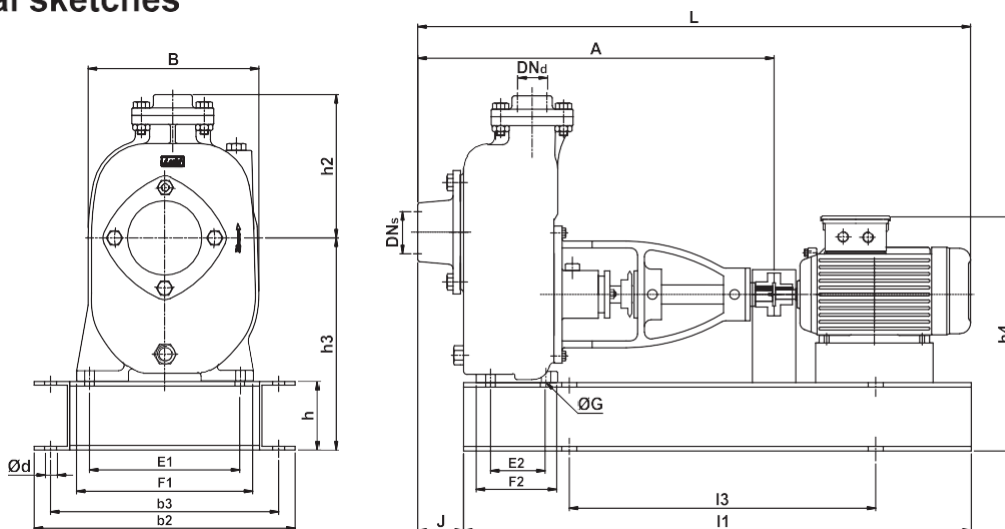

Dimensions & weights

Model	Power		DNs	DNd	Dimensions [mm]																Gross weight [kg]	Gross volume [m³]		
	[kW]	[HP]			A	B	E1	E2	F1	F2	ØG	J	h2	L	I1	I3	b2	b3	Ød	h			h3	h4
LBM 55	3.70	5.00	3"	3"	586	328	290	90	325	136	14	56	170	988	834	634	445	395	22	100	476	471	246.0	0.539
LBM 50	3.70	5.00	3"	3"	601	285	260	95	300	140	14	68	246	975	825	625	420	375	22	100	382	426	227.0	0.499
LBM 70	5.50	7.50	3"	3"	601	285	260	95	300	140	14	68	246	1064	878	678	420	370	22	100	382	462	265.0	0.538

Note: All dimensions in mm unless otherwise noted.
LBM 455 is diesel engine driven pumpset.

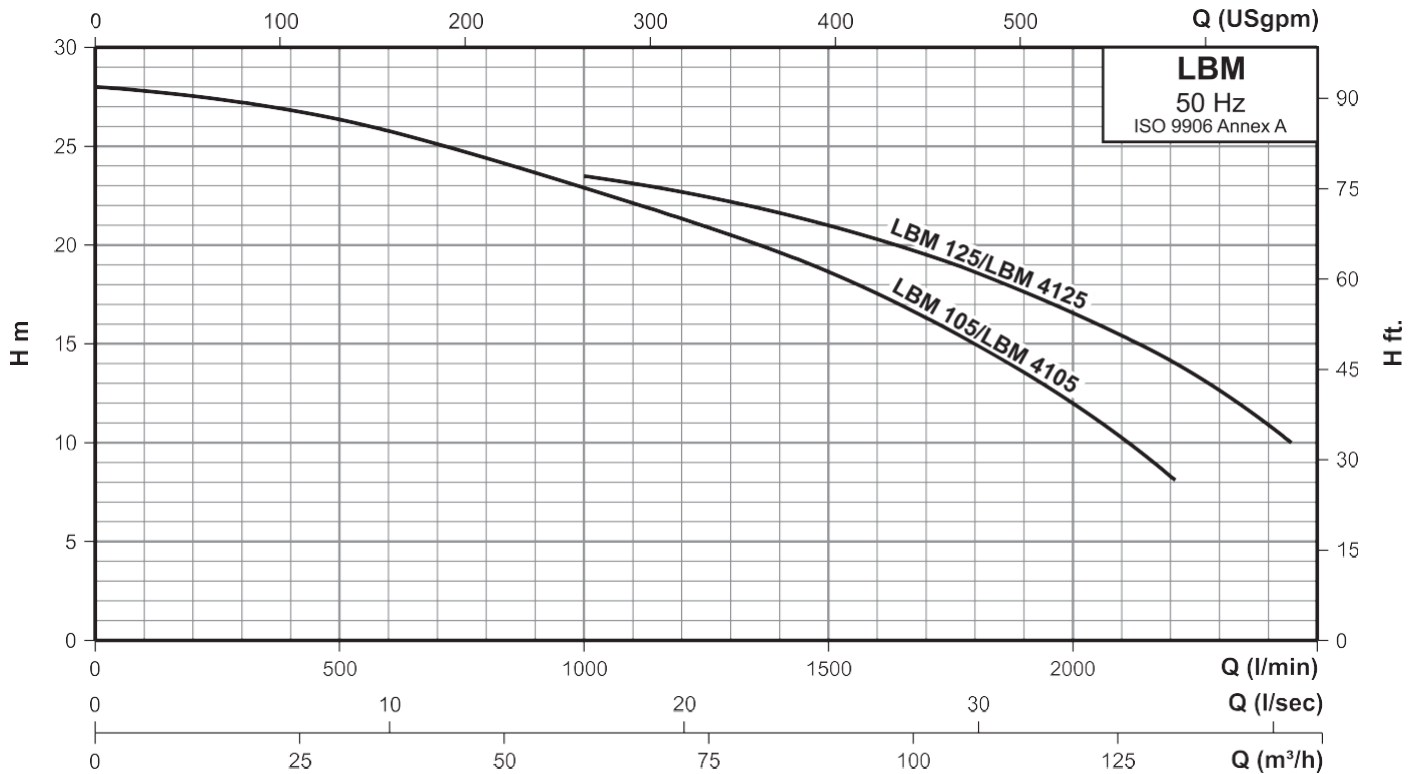

Performance data at n = 1450 rpm

Model	Power		Q m³/h	60	72	90	108	120	132	132
	[kW]	[HP]		Q l/min	1000	1200	1500	1800	2000	2200
LBM 105/LBM 4105	7.50	10.0	H mts.	22.9	21.4	18.6	15.2	12	8.2	8.2
LBM 125/LBM 4125	9.30	12.5		23.5	22.6	21	18.6	16.6	14.1	10.8

Dimensional sketches

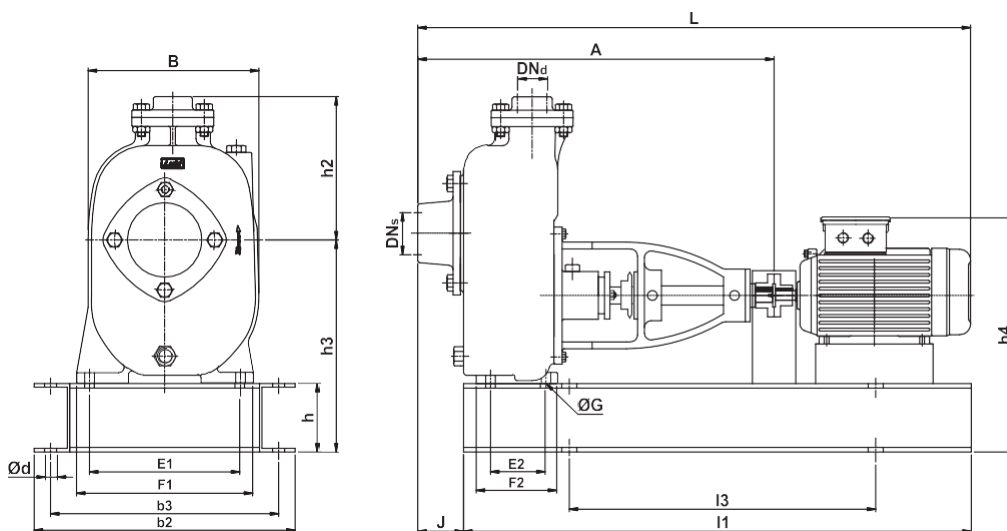

Dimensions & weights

Model	Power		DNs	DNd	Dimensions [mm]																Gross weight [kg]	Gross volume [m³]		
	[kW]	[HP]			A	B	E1	E2	F1	F2	ØG	J	h2	L	I1	I3	b2	b3	Ød	h			h3	h4
LBM 105	7.50	10.0	4"	4"	721	456	375	100	425	150	14	203	155	1222	900	700	545	495	22	100	593	500	426.0	0.856
LBM 125	9.30	12.5	4"	4"	671	446	380	100	425	150	14	125	219	1272	1006	403	545	495	22	100	590	592	448.0	1.040

Note: All dimensions in mm unless otherwise noted.

LBM 4105 & 4125 are diesel engine driven pumpset.

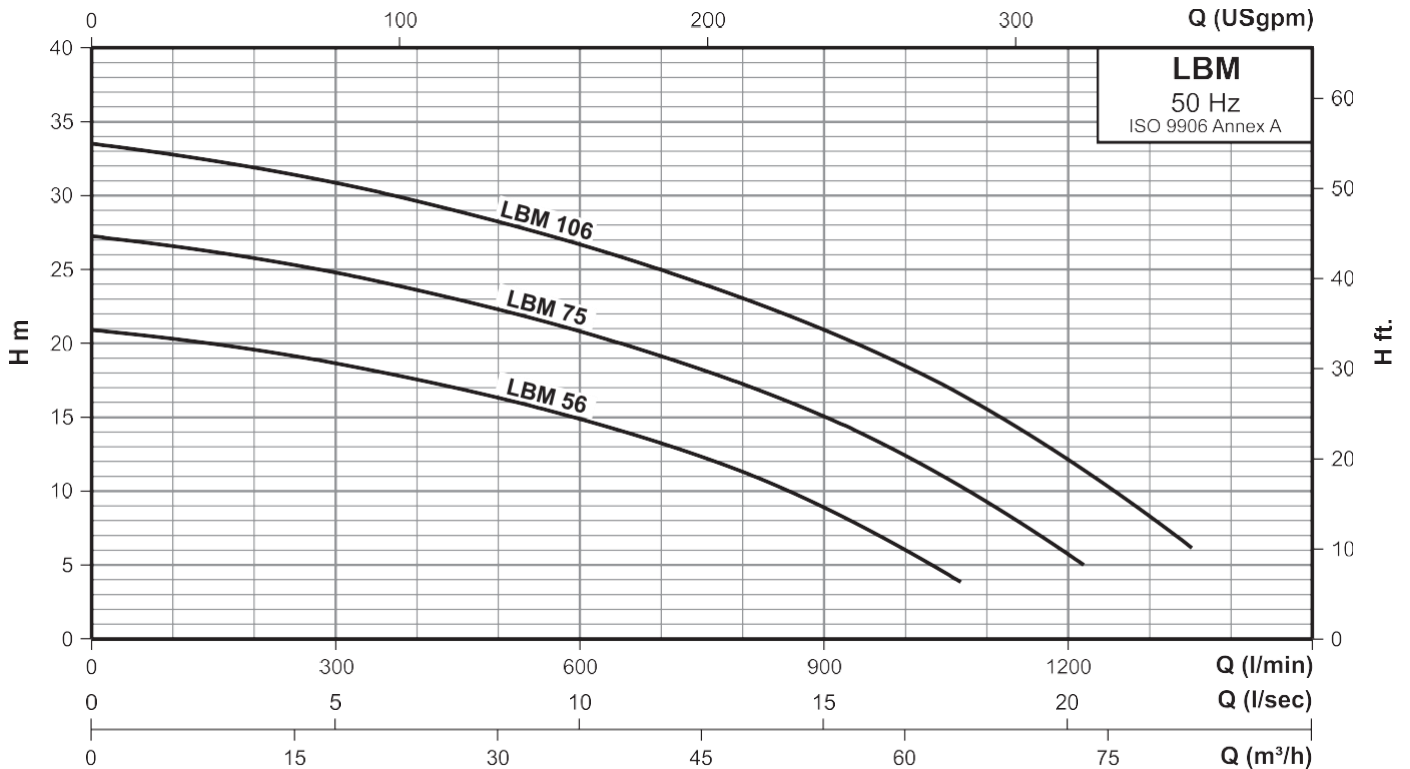

Performance data at n = 1450 rpm

Model	Power		Q m³/h	30	36	42	48	54	60	66	72	78
	[kW]	[HP]		Q l/min	500	600	700	800	900	1000	1100	1200
LBM 56	3.70	5.00	H mts.	16.4	14.9	13.2	11.3	9	6	-	-	-
LBM 75	5.50	7.50		22.3	20.9	19.1	17.2	15	12.4	9.2	5.9	-
LBM 106	7.50	10.0		28.2	26.8	25	23	21	18.5	15.6	12.1	8.3

Dimensional sketches

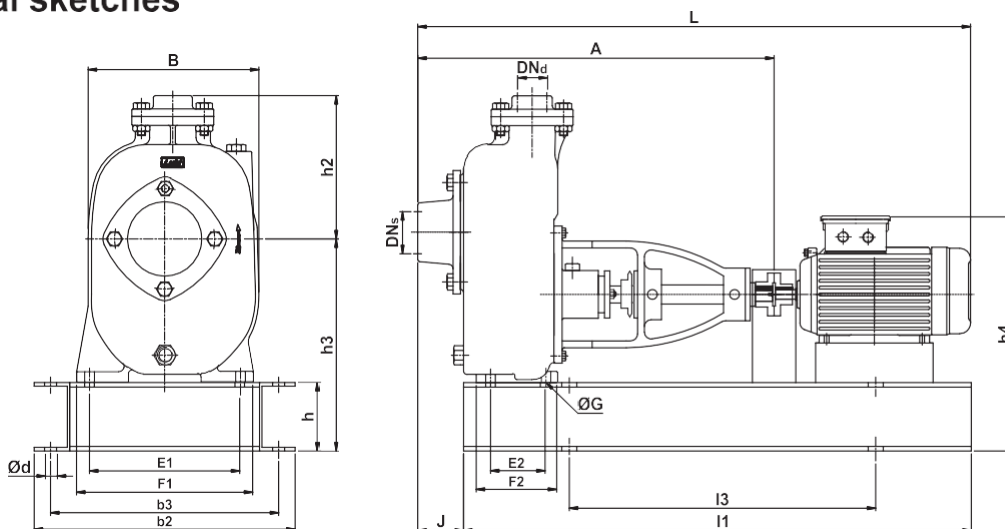

Dimensions & weights

Model	Power		DNs	DNd	Dimensions [mm]																Gross weight [kg]	Gross volume [m³]		
	[kW]	[HP]			A	B	E1	E2	F1	F2	ØG	J	h2	L	I1	I3	b2	b3	Ød	h			h3	h4
LBM 56	3.70	5.00	3"	3"	612	391	342	100	382	150	14	75	271	1012	835	635	492	442	22	100	490	482	290.0	0.680
LBM 75	5.50	7.50	3"	3"	612	391	342	100	382	150	14	75	271	1073	874	674	492	442	22	100	490	510	324.0	0.715
LBM 106	7.50	10.0	3"	3"	612	391	342	100	382	150	14	75	271	1111	912	712	492	442	22	100	490	510	360.0	0.738

Note: All dimensions in mm unless otherwise noted.

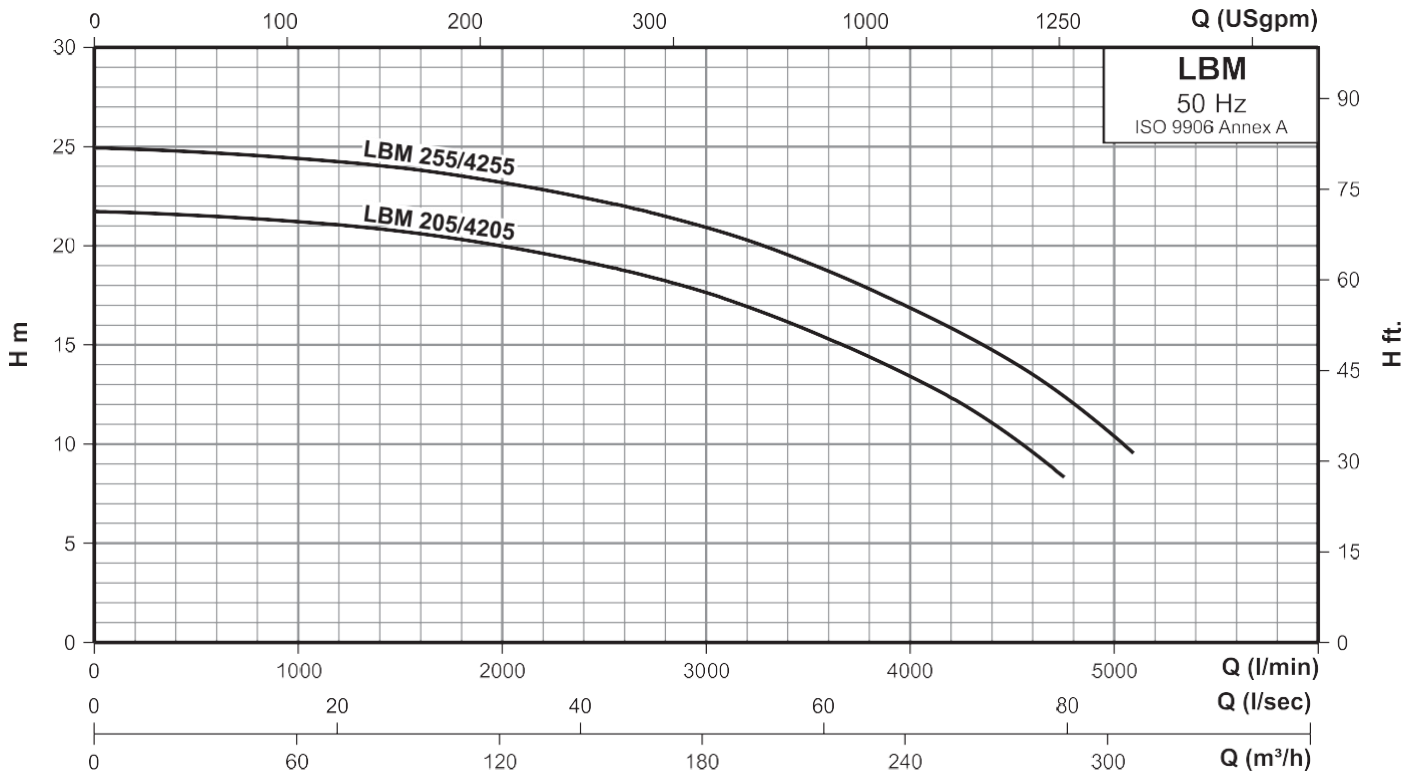

Performance data at n = 1450 rpm

Model	Power		Q m³/h Q l/min H mts.	60	90	120	150	180	210	240	270	300
	[kW]	[HP]		1000	1500	2000	2500	3000	3500	4000	4500	5000
LBM 205/LBM 4205	15.0	20.0		21.1	20.7	20	18.9	17.6	15.7	13.3	10.3	-
LBM 255/LBM 4255	18.5	25.0		24.3	23.8	23	22.1	20.8	18.9	16.7	14.1	10.3

Dimensional sketches

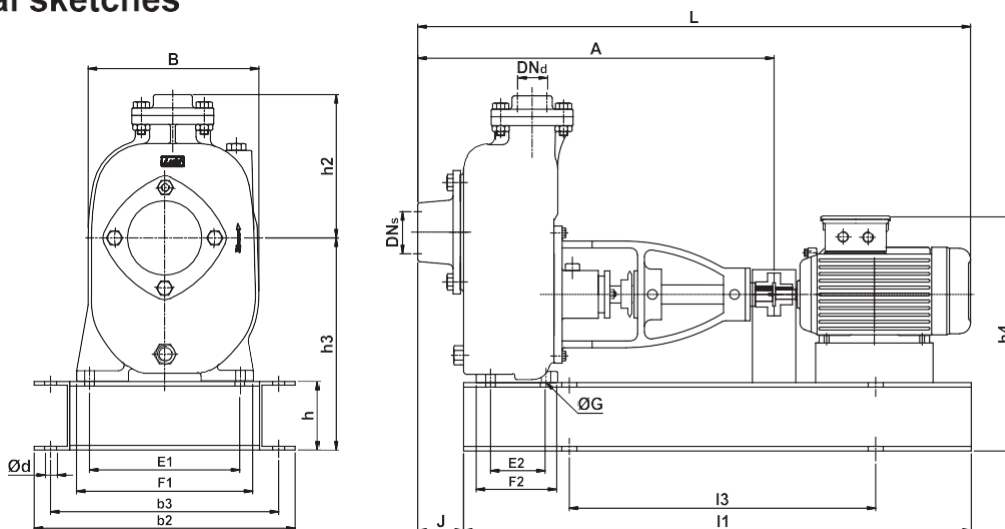

Dimensions & weights

Model	Power		DNs	DNd	Dimensions [mm]																Gross weight [kg]	Gross volume [m³]		
	[kW]	[HP]			A	B	E1	E2	F1	F2	ØG	J	h2	L	I1	I3	b2	b3	Ød	h			h3	h4
LBM 205	15.0	20.0	6"	6"	752	479	380	140	458	200	14	168	243	1395	1086	443	598	533	22	125	710	653	566.0	1.250
LBM 255	18.5	25.0	6"	6"	752	479	380	140	458	200	14	168	294	1476	1100	450	598	533	22	125	710	704	668.0	1.520

Note: All dimensions in mm unless otherwise noted.

LBM 4105 & 4125 are diesel engine driven pumpset.



Available with Your Trusted Partner for Water Treatment Solutions:



Workshop: 14-15, Panchratna Industrial Estate, Opp Satyam Mall, Sumip Composite-3 Lane, B/h VR Pilsulfate, Changodar-382213
Office: B-214, Nilkanth Palace, 100 feet Anandnagar Road, Satelite, Ahmedabad-380015
Phone: 9227418504/7227061661 | Email: sales@fiplco.com | Website: www.fiplco.com

