



Vertical multistage centrifugal pumps
50 Hz



PUMPS • MOTORS
ISO 9001 Company



Pumping Solution

Available with Your Trusted Partner for Water Treatment Solutions:





Photographs of a few Manufacturing Units



Management Service

CERTIFICATE

The Certification Body
of TÜV SÜD Management Service GmbH
Trading as TÜV SÜD South Asia Private Limited

certifies that



LUBI INDUSTRIES LLP [DIV.05]

A - 2, Lubi Industrial Park, Vadsar Khatraj Road, Vadsar
Dist. Gandhinagar- 382 721, Gujarat, INDIA

has established and applies
a Quality Management System for:

"Manufacturing, Supply and Service of Stainless Steel
Fabricated Submersible Pump Sets, Horizontal and Vertical
Multistage Centrifugal Pump Sets."

An audit was performed, Report No. 707021650.

Proof has been furnished that the requirements
according to

ISO 9001:2008

are fulfilled. The certificate is valid in conjunction
with the main-certificate from 2014-02-04 until 2017-02-03.

Certificate Registration No. 12 100 47334/02 TMS

Product Compliance Management
Munich, 2014-02-10



Deutsche
Akkreditierungsstelle
D-2M 14143-01-03

ZERTIFIKAT ♦ CERTIFICATE ♦ 認證證書 ♦ CERTIFICADO ♦ CERTIFICAT

Declaration of Conformity

We, **Lubi** hereby declare under our sole responsibility that the products **LCR**, **LCRI** and **LCRN** to which this declaration relates, are in conformity with these Council Directives on the approximation of the laws of the EC Member States:

- Machinery Directive (2006/42/EC).
Standard used: EN 809: 2009.
- Electromagnetic compatibility (2004/108/EC).
Standards used: EN 61000-6-2 and EN 61000-6-3.

Nosotros, **Lubi** declaramos bajo nuestra entera responsabilidad que los productos **LCR**, **LCRI** y **LCRN**, a los cuales se refiere esta declaración, están conformes con las Directivas del Consejo en la aproximación de las leyes de los Estados Miembros del EM:

- Directiva de Maquinaria (2006/42/CE).
Normas aplicada: EN 809: 2009.
- Compatibilidad electromagnética (2004/108/CE).
Normas aplicadas: EN 61000-6-2 y EN 61000-6-3.

Nous, **Lubi** déclarons sous notre seule responsabilité, que les produits **LCR**, **LCRI** et **LCRN**, auxquels se réfère cette déclaration, sont conformes aux Directives du Conseil concernant le rapprochement des législations des Etats membres CE relatives aux normes énoncées cidessous:

- Directive Machines (2006/42/CE).
Norme utilisées: EN 809: 2009.
- Compatibilité électromagnétique (2004/108/CE).
Normes utilisées: EN 61000-6-2 et EN 61000-6-3.

J.J. Amin

Technical Director



Contents

Vertical multistage centrifugal pumps

Product Data

Introduction	6	LCR 32	60
Performance range - LCR, LCRI, LCRN	6	LCRI, LCRN 32	62
Minimum cost of ownership	7	LCR 45	64
Applications	7	LCRI, LCRN 45	66
Product range	8	LCR 64	68
Pump	11	LCRI, LCRN 64	70
Motor	11	LCR 90	72
Terminal box positions	11	LCRI, LCRN 90	74
Ambient temperature	11	LCR 120	76
Viscosity	11	LCRN 120	78
		LCR 150	80
		LCRN 150	82

Construction

LCR 1s, 1, 2, 3, 4, 5, 10, 15 and 20	12
LCRI, LCRN 1s, 1, 2, 3, 4, 5, 10, 15 and 20	12
LCR 32, 45, 64 and 90	13
LCRI, LCRN 32, 45, 64 and 90	13
LCR 120 and 150	14
LCRN 120 and 150	14
Type keys	15

Operating and inlet pressures

Maximum operating pressure and temperature range	16
Operating range of the shaft seal	16
Maximum inlet pressure	17

Selection and sizing

Selection of pumps	18
Minimum inlet pressure	20
How to read the curve charts	21
Guidelines to performance curves	21

Pumped liquids

Pumped liquids	22
----------------	----

Motor data

Standard motors for LCR, LCRI, LCRN - 50 Hz	23
---	----

Performance curves/technical data

LCR 1s	24
LCRI, LCRN 1s	26
LCR 1	28
LCRI, LCRN 1	30
LCR 2	32
LCRI, LCRN 2	34
LCR 3	36
LCRI, LCRN 3	38
LCR 4	40
LCRI, LCRN 4	42
LCR 5	44
LCRI, LCRN 5	46
LCR 10	48
LCRI, LCRN 10	50
LCR 15	52
LCRI, LCRN 15	54
LCR 20	56
LCRI, LCRN 20	58

Product data

LCR, LCRI, LCRN

Vertical multistage centrifugal pumps

Introduction

This data booklet deals with LCR, LCRI and LCRN pumps.

LCR, LCRI and LCRN pumps are vertical multistage centrifugal pumps. The vertical in-line design enables the pump to be installed in a horizontal plane single system where the suction and discharge connections are in the same horizontal plane and have the same pipe sizes. This design provides a more compact pump design saving space and easy pipework.

Lubi LCR pumps come with various sizes and various numbers of stages to provide the flow and the pressure for different site conditions.

LCR pumps are suitable for a wide variety of applications from pumping of potable water to the pumping of chemicals.

LCR pumps are available in various material versions according to the pumped liquid.



Fig. 1 LCR, LCRI and LCRN pumps

Performance range - LCR, LCRI, LCRN

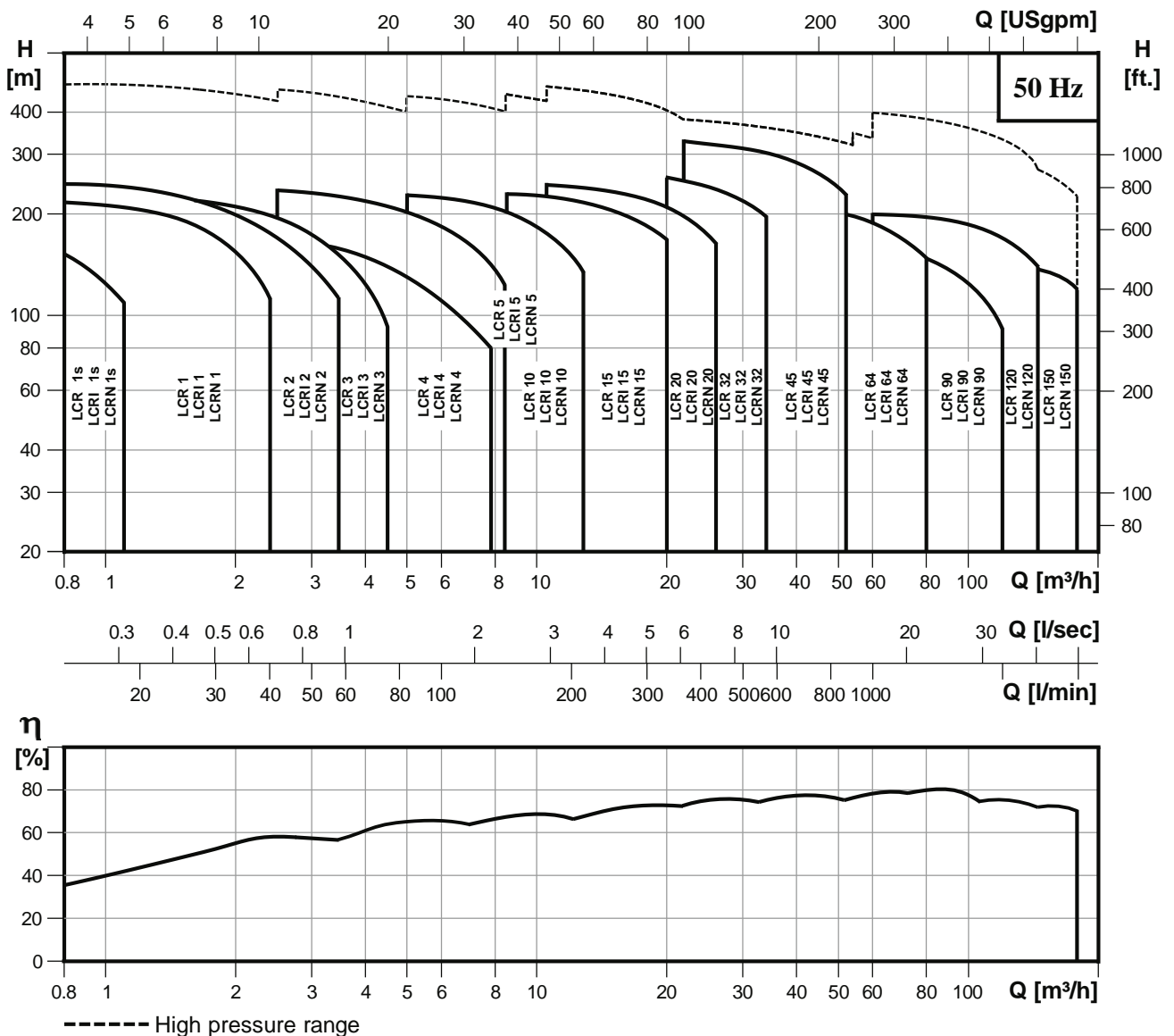

Product data

Vertical multistage centrifugal pumps Minimum cost of ownership

LCR, LCRI, LCRN

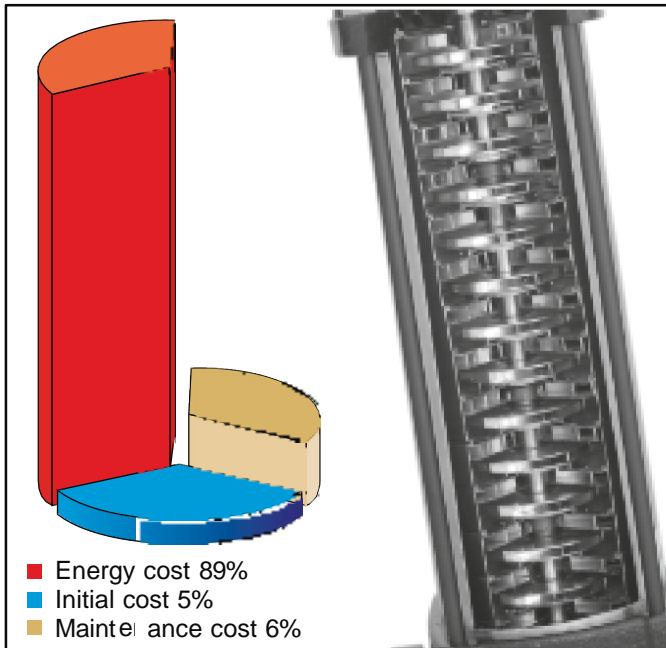

The initial cost of purchasing a pump is fraction of the total cost of owning and operating a pump over its entire life span.

Energy cost + Maintenance cost contribute to a 95% of the total cost of ownership and out of this 89% is energy cost. This is where Lubi LCR pump can make a difference against other pumps.

When pumps are running round the clock even a 10% increase in pump efficiency will quickly transform into significant saving in energy cost month after month over the entire life span of the pump.

Applications

Application	LCR, LCRI	LCRN
Water supply Filtration and transfer at waterworks Distribution from waterworks Pressure boosting in mains Pressure boosting in high-rise buildings, hotels, etc. Pressure boosting for industrial water supply	● ●	●● ●●
Industry Pressure boosting in... Process-water systems Washing and cleaning systems Vehicle washing tunnels Fire-fighting systems Liquid transfer in... Cooling and air-conditioning systems (refrigerants) Boiler feed and condensate systems Machine tools (cooling lubricants) Aquafarming Transfer of... Oils and alcohols Acids and alkalis Glycol and coolants	● ● ● ● ● ●	● ●● ●● ●● ●● ●
Water treatment Ultra-filtration systems Reverse osmosis systems Softening, ionizing, demineralizing systems Distillation systems Separators Swimming baths	● ●	● ● ●
Irrigation Field irrigation (flooding) Sprinkler irrigation Drip-feed irrigation	●	●●

● Recommended version.

●● Alternative version.

Product data

LCR, LCRI, LCRN

Vertical multistage centrifugal pumps

Product range

Range	LCR 1s	LCR 1	LCR 2	LCR 3	LCR 4
Nominal flow rate [m ³ /h]	0.8	1	2	3	4
Temperature range [°C]	-20 to +120	-20 to +120	-20 to +120	-20 to +120	-20 to +120
Temperature range [°C] - on request	-40 to +180	-40 to +180	-40 to +180	-40 to +180	-40 to +180
Max. Pump efficiency [%]	35	48	48	58	60
LCR pumps					
Flow range [m ³ /h]	0.3-1.1	0.7-2.4	1-3.5	1.2-4.5	2-7.9
Max.pressure [bar]	21	22	25	24	22
High pressure [bar] - on request	-	47	47	47	47
Motor power [kW]	0.37-1.1	0.37-2.2	0.37-3	0.37-3	0.37-4
Version					
LCR:					
Cast iron and	●	●	●	●	●
Stainless steel EN 1.4301/AISI 304					
LCRI:					
Stainless steel EN 1.4301/AISI 304	●	●	●	●	●
LCRN:					
Stainless steel EN 1.4401/AISI 316	●	●	●	●	●
LCR pipe connection**					
Oval flange (BSP)	Rp 1	Rp 1	Rp 1	Rp 1	Rp 1½
Oval flange (BSP) - on request	Rp 1¼	Rp 1¼	Rp 1¼	Rp 1¼	Rp 1
Flange	DN 32	DN 32	DN 32	DN 32	DN 32
Flange - on request	-	-	-	-	-
LCRI pipe connection**					
Oval flange (BSP)	Rp 1	Rp 1	Rp 1	Rp 1	Rp 1½
Oval flange (BSP) - on request	Rp 1¼	Rp 1¼	Rp 1¼	Rp 1¼	Rp 1
Flange	DN 32	DN 32	DN 32	DN 32	DN 32
Flange - on request	-	-	-	-	-
LCRN pipe connection**					
Oval flange (BSP)	Rp 1	Rp 1	Rp 1	Rp 1	Rp 1½
Oval flange (BSP) - on request	Rp 1¼	Rp 1¼	Rp 1¼	Rp 1¼	Rp 1
Flange	DN 32	DN 32	DN 32	DN 32	DN 32
Flange - on request	-	-	-	-	-
Mechanical shaft seal					
Bellow type shaft seal	2 to 27 stage	2 to 27 stage	2 to 18 stage	2 to 25 stage	2 to 16 stage
Bellow type shaft seal material	Carbon/Sic/ SS 316/EPDM	Carbon/Sic/ SS 316/EPDM	Carbon/Sic/ SS 316/EPDM	Carbon/Sic/ SS 316/EPDM	Carbon/Sic/ SS 316/EPDM
	Carbon/Sic/ SS 316/FKM*	Carbon/Sic/ SS 316/FKM*	Carbon/Sic/ SS 316/FKM*	Carbon/Sic/ SS 316/FKM*	Carbon/Sic/ SS 316/FKM*
Cartridge type shaft seal	30 to 36 stage	30 to 36 stage	22 to 26 stage	27 to 36 stage	19 to 22 stage
Cartridge type shaft seal material	Carbon/Sic/ SS 316/FKM	Carbon/Sic/ SS 316/FKM	Carbon/Sic/ SS 316/FKM	Carbon/Sic/ SS 316/FKM	Carbon/Sic/ SS 316/FKM
	Sic/Sic/ SS 316/FKM*	Sic/Sic/ SS 316/FKM*	Sic/Sic/ SS 316/FKM*	Sic/Sic/ SS 316/FKM*	Sic/Sic/ SS 316/FKM*

Recommended version.

●● Alternative version.

* Available on request.

** All pumps are supplied with counter flanges.

Product data

LCR, LCRI, LCRN

Vertical multistage centrifugal pumps

Product range

Range	LCR 5	LCR 10	LCR 15	LCR 20	LCR 32
Nominal flow rate [m ³ /h]	5	10	15	20	32
Temperature range [°C]	-20 to +120	-20 to +120	-20 to +120	-20 to +120	-30 to +120
Temperature range [°C] - on request	-40 to +180	-40 to +180	-40 to +180	-40 to +180	-40 to +180
Max. Pump efficiency [%]	66	70	72	72	78
LCR pumps					
Flow range [m ³ /h]	2.5-8.5	5-13	9-24	11-29	15-40
Max.pressure [bar]	24	22	23	25	28
High pressure [bar] - on request	47	47	47	47	39
Motor power [kW]	0.37-5.5	0.37-7.5	1.1-15	1.1-18.5	1.5-30
Version					
LCR:					
Cast iron and Stainless steel EN 1.4301/AISI 304	●	●	●	●	●
LCRI:					
Stainless steel EN 1.4301/AISI 304	●	●	●	●	●●
LCRN:					
Stainless steel EN 1.4401/AISI 316	●	●	●	●	●
LCR pipe connection**					
Oval flange (BSP)	Rp 1¼	-	-	-	-
Oval flange (BSP) - on request	Rp 1	-	-	-	-
Flange	DN 32	DN 40	DN 50	DN 50	DN 65
Flange - on request	-	DN 50	-	-	DN 80
LCRI pipe connection**					
Oval flange (BSP)	Rp 1¼	-	-	-	-
Oval flange (BSP) - on request	Rp 1	-	-	-	-
Flange	DN 32	DN 40	DN 50	DN 50	DN 65
Flange - on request	-	DN 50	-	-	DN 80
LCRN pipe connection**					
Oval flange (BSP)	Rp 1¼	-	-	-	-
Oval flange (BSP) - on request	Rp 1	-	-	-	-
Flange	DN 32	DN 40	DN 50	DN 50	DN 65
Flange - on request	-	DN 50	-	-	DN 80
Mechanical shaft seal					
Bellow type shaft seal	2 to 24 stage	1 to 16 stage	1 to 12 stage	1 to 12 stage	-
Bellow type shaft seal material	Carbon/Sic/ SS 316/EPDM	Carbon/Sic/ SS 316/EPDM	Carbon/Sic/ SS 316/EPDM	Carbon/Sic/ SS 316/EPDM	-
	Carbon/Sic/ SS 316/FKM*	Carbon/Sic/ SS 316/FKM*	Carbon/Sic/ SS 316/FKM*	Carbon/Sic/ SS 316/FKM*	-
Cartridge type shaft seal	26 to 36 stage	18 to 22 stage	14 to 17 stage	14 to 17 stage	All stages
Cartridge type shaft seal material	Carbon/Sic/ SS 316/FKM	Carbon/Sic/ SS 316/FKM	Carbon/Sic/ SS 316/FKM	Carbon/Sic/ SS 316/FKM	Carbon/Sic/ SS 316/FKM
	Sic/Sic/ SS 316/FKM*	Sic/Sic/ SS 316/FKM*	Sic/Sic/ SS 316/FKM*	Sic/Sic/ SS 316/FKM*	Sic/Sic/ SS 316/FKM*

Recommended version.

●● Alternative version.

* Available on request.

** All pumps are supplied with counter flanges.

Product data

LCR, LCRI, LCRN

Vertical multistage centrifugal pumps

Product range

Range	LCR 45	LCR 64	LCR 90	LCR 120	LCR 150
Nominal flow rate [m ³ /h]	45	64	90	120	150
Temperature range [°C]	-30 to +120	-30 to +120	-30 to +120	-30 to +120	-30 to +120
Temperature range [°C] - on request	-40 to +180	-40 to +180	-40 to +180	-40 to +180	-40 to +180
Max. Pump efficiency [%]	79	80	81	75	72
LCR pumps					
Flow range [m ³ /h]	22-58	30-85	45-120	60-160	75-180
Max.pressure [bar]	26	20	20	21	19
High pressure [bar] - on request	40	39	39	41	39
Motor power [kW]	3-45	4-45	5.5-45	11-75	11-75
Version					
LCR:					
Cast iron and Stainless steel EN 1.4301/AISI 304	●	●	●	●	●
LCRI:					
Stainless steel EN 1.4301/AISI 304	●●	●●	●●	-	-
LCRN:					
Stainless steel EN 1.4401/AISI 316	●	●	●	●	●
LCR pipe connection**					
Oval flange (BSP)	-	-	-	-	-
Oval flange (BSP) - on request	-	-	-	-	-
Flange	DN 80	DN 100	DN 100	DN 125	DN 125
Flange - on request	DN 100	DN 125	DN 125	DN 150	DN 150
LCRI pipe connection**					
Oval flange (BSP)	-	-	-	-	-
Oval flange (BSP) - on request	-	-	-	-	-
Flange	DN 80	DN 100	DN 100	DN 125	DN 125
Flange - on request	DN 100	DN 125	DN 125	DN 150	DN 150
LCRN pipe connection**					
Oval flange (BSP)	-	-	-	-	-
Oval flange (BSP) - on request	-	-	-	-	-
Flange	DN 80	DN 100	DN 100	DN 125	DN 125
Flange - on request	DN 100	DN 125	DN 125	DN 150	DN 150
Mechanical shaft seal					
Bellow type shaft seal	-	-	-	-	-
Bellow type shaft seal material	-	-	-	-	-
	-	-	-	-	-
Cartridge type shaft seal					
Cartridge type shaft seal material	All stages Carbon/Sic/ SS 316/FKM	All stages Carbon/Sic/ SS 316/FKM	All stages Carbon/Sic/ SS 316/FKM	All stages Carbon/Sic/ SS 316/FKM	All stages Carbon/Sic/ SS 316/FKM
	Sic/Sic/ SS 316/FKM*	Sic/Sic/ SS 316/FKM*	Sic/Sic/ SS 316/FKM*	Sic/Sic/ SS 316/FKM*	Sic/Sic/ SS 316/FKM*

Recommended version.

●● Alternative version.

* Available on request.

** All pumps are supplied with counter flanges.

Product data

Vertical multistage centrifugal pumps

Pump

The LCR pumps are non-self-priming, vertical multistage centrifugal pumps.

The pump consists of a base and a pump head. The chamber stack and the outer sleeve are secured between the pump head and the base by means of tiebolts. The base has suction and discharge connections on the same level (in-line).

All pumps are equipped with a maintenance-free mechanical shaft seal.

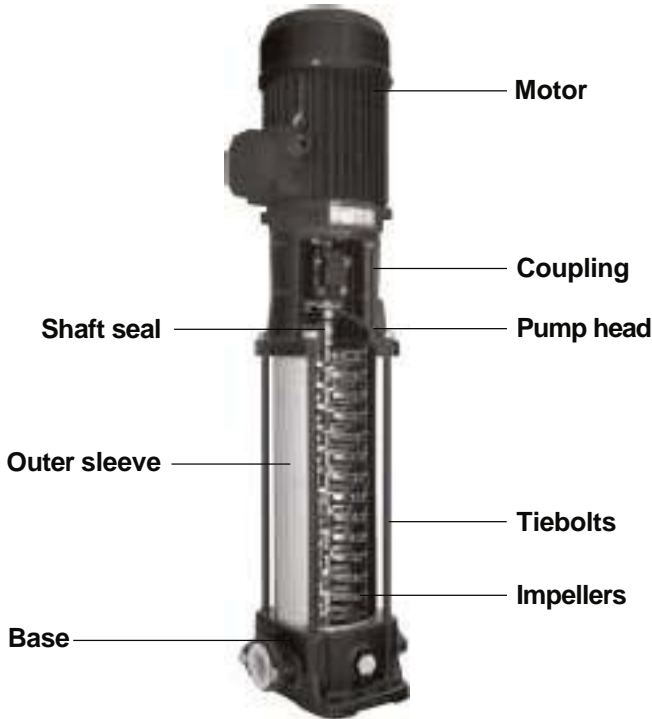

Fig. 2 LCR pump

Motor

LCR, LCRI and LCRN pumps are fitted with a totally enclosed, fan-cooled, 2-pole motor with principal dimensions in accordance with the EN standards.

Electrical tolerances according to EN 60034.

From 0.37 to 2.2 kW Lubi offers LCR pumps fitted with single-phase motors (1 x 220-230/240 V).

Electrical data

LCR, LCRI, LCRN pumps

	LUBI motor
Mounting designation	Up to 4 kW: V 18 From 5.5 kW: V 1
Insulation class	F
Efficiency class	EFF 2
Enclosure class	IP 55
Supply voltage (Tolerance: ±10%)	P ₂ : 0.37-1.5 kW: 3 x 220-240/380-415 V, 50 Hz P ₂ : 2.2-75 kW: 3 x 380-415 V, 50 Hz
Supply frequency	50 Hz

LCR, LCRI, LCRN

Terminal box positions

As standard the terminal box is mounted on the suction side of the pump.

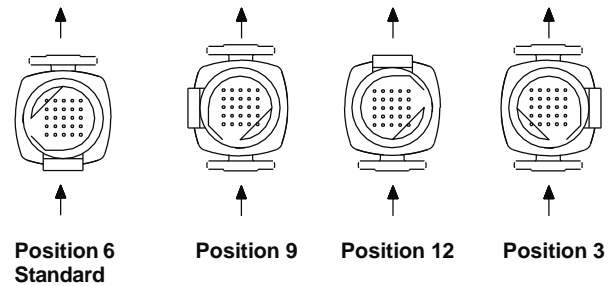

Fig. 3 Terminal box positions

Ambient temperature

If the ambient temperature exceeds 40°C or the pump is installed at an altitude exceeding 1000 m above sea level, the motor must not be fully loaded due to the risk of overheating. Overheating may result from excessive ambient temperature or the low density and consequently low cooling effect of the air.

In such cases, it may be necessary to use a motor with a higher rated output.

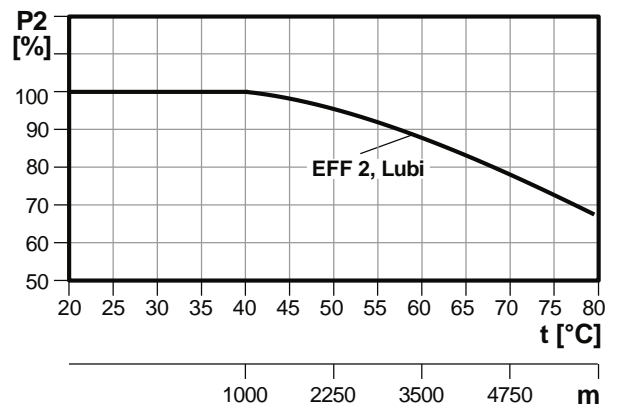

Fig. 4 Relationship between motor output (P₂) and ambient temperature

Viscosity

The pumping of liquids with densities or kinematic viscosities higher than those of water will cause a considerable pressure drop, a drop in the hydraulic performance and a rise in the power consumption.

In such situations the pump should be equipped with a larger motor. If in doubt, contact Lubi.

Construction

Vertical multistage centrifugal pumps

LCR 1s, 1, 2, 3, 4, 5, 10, 15 and 20



Sectional drawing

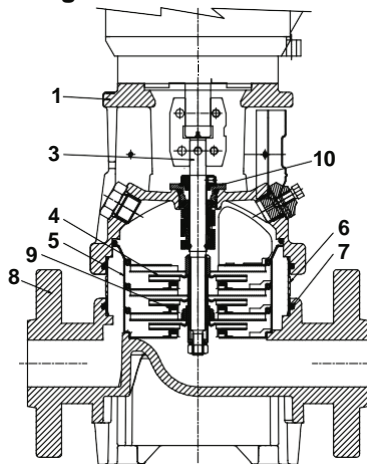

Materials: LCR

Nos.	Designation	Materials	EN/DIN	AISI/ASTM
1	Pump Head	Cast iron EN-GJL-200	EN-JL1030	ASTM 25B
3	Shaft	Stainless steel	1.4401	AISI 316 AISI 431
4	Impeller	Stainless steel	1.4301	AISI 304
5	Chamber	Stainless steel	1.4301	AISI 304
6	Outer sleeve	Stainless steel	1.4301	AISI 304
7	O-ring for outer sleeve	EPDM or FKM		
8	Base	Cast iron EN-GJL-200	EN-JL1030	ASTM 25B
9	Neck ring	PTFE		
10	Shaft seal*	Bellow type/ Cartridge type Rubber parts		

* For more details on shaft seal see, page 8 to 10.

LCR, LCRI, LCRN

LCRI, LCRN 1s, 1, 2, 3, 4, 5, 10, 15 and 20



Sectional drawing

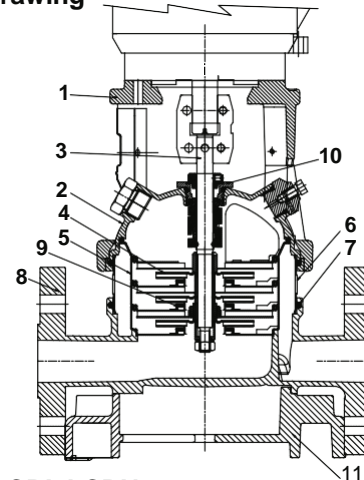

Materials: LCRI, LCRN

Nos.	Designation	Materials	EN/DIN	AISI/ASTM
1	Pump head	Cast iron EN-GJL-200	EN-JL1030	ASTM 25B
3	Shaft	Stainless steel	1.4401 1.4460	AISI 316 AISI 329
7	O-ring for outer sleeve	EPDM or FKM		
9	Neck ring	PTFE		
10	Shaft seal*	Bellow type/ Cartridge type		
11	Base plate	Cast iron EN-GJL-200 Rubber parts	EN-JL1030	ASTM 25B

LCRI

2	Pump head cover	Stainless steel	1.4308	CF 8 eq. to AISI 304
4	Impeller	Stainless steel	1.4301	AISI 304
5	Chamber	Stainless steel	1.4301	AISI 304
6	Outer sleeve	Stainless steel	1.4301	AISI 304
8	Base	Stainless steel	1.4308	CF 8 eq. to AISI 304

LCRN

2	Pump head cover	Stainless steel	1.4408	CF 8M eq. to AISI 316
4	Impeller	Stainless steel	1.4401	AISI 316
5	Chamber	Stainless steel	1.4401	AISI 316
6	Outer sleeve	Stainless steel	1.4401	AISI 316
8	Base	Stainless steel	1.4408	CF 8M eq. to AISI 316

Construction

Vertical multistage centrifugal pumps

LCR 32, 45, 64 and 90



Sectional drawing

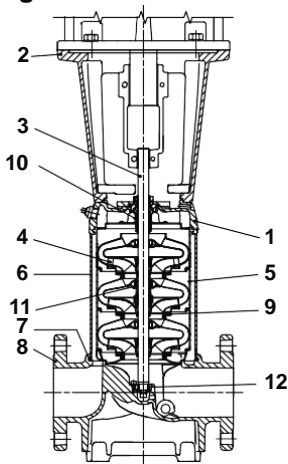

Materials: LCR

Nos.	Designation	Materials	EN/DIN	AISI/ASTM
1	Pump head	Cast iron EN-GJS-500-7	EN-JS1050	ASTM 80-55-06
2	Motor stool	Cast iron EN-GJL-200	EN-JL1030	ASTM 25B
3	Shaft	Stainless steel	1.4057	AISI 431
4	Impeller	Stainless steel	1.4301	AISI 304
5	Chamber	Stainless steel	1.4301	AISI 304
6	Outer sleeve	Stainless steel	1.4301	AISI 304
7	O ring for outer sleeve	EPDM or FKM		
8	Base	Cast iron EN-GJS-500-7	EN-JS1050	ASTM 80-55-06
9	Neck ring	Carbon- graphite filled PTFE		
10	Shaft seal*	Cartridge type		
11	Bearing ring	Bronze		
12	Bottom bearing ring Rubber parts	Sic/Sic EPDM or FKM		

* For more details on shaft seal, see page 8 to 10.

LCR, LCRI, LCRN

LCRI, LCRN 32, 45, 64 and 90



Sectional drawing

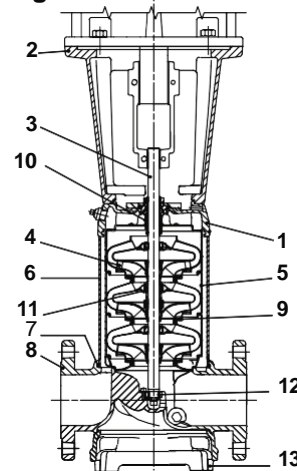

Materials: LCRI, LCRN

Nos.	Designation	Materials	EN/DIN	AISI/ASTM
2	Motor stool	Cast iron EN-GJL-200	EN-JL1030	ASTM 25B
3	Shaft	Stainless steel	1.4462	
7	O-ring for outer sleeve	EPDM or FKM		
9	Neck ring	Carbon- graphite filled PTFE		
10	Shaft seal*	Cartridge type		
11	Bearing ring	Carbon- graphite filled PTFE		
12	Bottom bearing ring	Sic/Sic		
13	Base plate Rubber parts	Cast iron EN-GJS-500-7 EPDM or FKM	EN-JS1050	ASTM 80-55-06

LCRI

1	Pump head	Stainless steel	1.4308	CF 8 eq. to AISI 304
4	Impeller	Stainless steel	1.4301	AISI 304
5	Chamber	Stainless steel	1.4301	AISI 304
6	Outer sleeve	Stainless steel	1.4301	AISI 304
8	Base	Stainless steel	1.4308	CF 8 eq. to AISI 304

LCRN

1	Pump head	Stainless steel	1.4408	CF 8M eq. to AISI 316
4	Impeller	Stainless steel	1.4401	AISI 316
5	Chamber	Stainless steel	1.4401	AISI 316
6	Outer sleeve	Stainless steel	1.4401	AISI 316
8	Base	Stainless steel	1.4408	CF 8M eq. to AISI 316

Construction

Vertical multistage centrifugal pumps

LCR 120 and 150



Sectional drawing

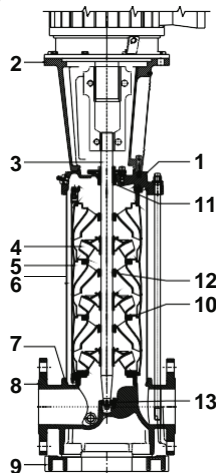

Materials: LCR

Nos.	Designation	Materials	EN/DIN	AISI/ASTM
1	Pump head	Cast iron EN-GJS-500-7	EN-JS1050	A 536 65-45-12
2	Motor stool (11-45 kW)	Cast iron EN-GJL-200	EN-JL1030	A48-30 B
	Motor stool (55-75 kW)	Cast iron EN-GJS-500-7	EN-JS1050	A 536 65-45-12
3	Shaft	Stainless steel	1.4057	AISI 431
4	Impeller	Stainless steel	1.4301	AISI 304
5	Chamber	Stainless steel	1.4301	AISI 304
6	Outer sleeve	Stainless steel	1.4301	AISI 304
7	O ring for outer sleeve	EPDM or FKM		
8	Base	Cast iron EN-GJS-500-7	EN-JS1050	A 536 65-45-12
9	Base plate	Cast iron EN-GJS-500-7	EN-JS1050	A 536 65-45-12
10	Neck ring	Carbon- graphite filled PTFE/NBR		
11	Shaft seal*	Cartridge type		
12	Support bearing	Carbon- graphite filled PTFE		
13	Bearing ring	Tungsten carbide		
	Rubber parts	EPDM or FKM		

* For more details on shaft seal, see page 8 to10.
 Ø22 mm shaft - 11 to 45 kW
 Ø32 mm shaft - 55 to 75 kW

LCR, LCRI, LCRN

LCRN 120 and 150



Sectional drawing

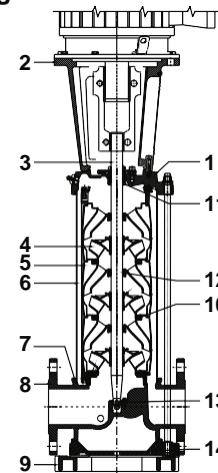

Materials: LCRN

Nos.	Designation	Materials	EN/DIN	AISI/ASTM
2	Motor stool (11-45 kW)	Cast iron EN-GJL-200	EN-JL1030	A48-30 B
	Motor stool (55-75 kW)	Cast iron EN-GJS-500-7	EN-JS1050	A 536 65-45-12
3	Shaft	Stainless steel	1.4462 1.4401	
7	O-ring for outer sleeve	EPDM or FKM		
9	Base plate	Cast iron EN-GJS-500-7	EN-JS1050	A 536 65-45-12
10	Neck ring	Carbon- graphite filled PTFE/NBR		
11	Shaft seal*	Cartridge type		
12	Support bearing	Carbon- graphite filled PTFE		
13	Bearing ring	Tungsten carbide		
14	Base plate	Cast iron EN-GJS-500-7	EN-JS1050	A 536 65-45-12
	Rubber parts	EPDM or FKM		

LCRN

1	Pump head	Stainless steel	1.4408	CF 8M eq. to AISI 316
4	Impeller	Stainless steel	1.4401	AISI 316
5	Chamber	Stainless steel	1.4401	AISI 316
6	Outer sleeve	Stainless steel	1.4401	AISI 316
8	Base	Stainless steel	1.4408	CF 8M eq. to AISI 316

* For more details on shaft seal, see page 8 to10.
 Ø22 mm shaft - 11 to 45 kW
 Ø32 mm shaft - 55 to 75 kW

Construction

Vertical multistage centrifugal pumps

LCR, LCRI, LCRN

Type keys

LCR, LCRI, LCRN

Example LCR 32 s 4 2 F D E H BQ E

Type range:

LCR, LCRI, LCRN

Flow rate [m³/h]

All impellers with reduced diameter (applies only to LCR, LCRI, LCRN 1s)

Number of impellers

Number of reduced diameter impellers

1 or 2 or no number if reduced diameter impellers are not provided

Code for pipe connection

Code for bearing materials

Code for rubber part materials

Code for type of shaft seals

Code for shaft seal face materials

Code for shaft seal rubber materials

Codes

Example

F D E H BQ E

Code for pipe connection

A Oval flange

F DIN flange*

G ANSI flange

J JIS flange

Code for bearing materials

D Carbon-graphite filled PTFE v/s Stainless steel AIS 304

E Carbon-graphite filled PTFE v/s Stainless steel AIS 316

X Ceramic v/s Tugsten carbide

Code for rubber part materials

E EPDM*

V Viton®***

Code for type of shaft seals

B Bellow type**

H Cartridge type**

Code for shaft seal face materials

B Carbon

Q Silicon carbide

Code for shaft seal rubber materials

E EPDM

V Viton®***

* Standard construction.

** For more details on shaft seal, see page 8 to 10.

*** Viton® is a registered trademark of DuPont Performance Elastomers L.L.C..

Operating and inlet pressures

Vertical multistage centrifugal pumps

LCR, LCRI, LCRN

Maximum operating pressure and temperature range

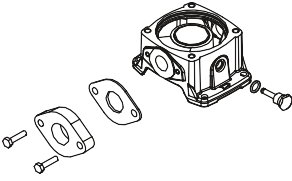
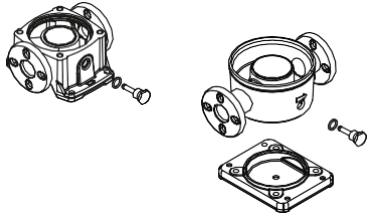
	 Oval flange		 DIN flange	
	Max. permissible operating pressure	Liquid temperature range	Max. permissible operating pressure	Liquid temperature range
LCR 1s	16 bar	-20°C to +120°C	25 bar	-20°C to +120°C
LCRI, LCRN 1s	16 bar	-20°C to +120°C	25 bar	-20°C to +120°C
LCR 1	16 bar	-20°C to +120°C	25 bar	-20°C to +120°C
LCRI, LCRN 1	16 bar	-20°C to +120°C	25 bar	-20°C to +120°C
LCR 2	16 bar	-20°C to +120°C	25 bar	-20°C to +120°C
LCRI, LCRN 2	16 bar	-20°C to +120°C	25 bar	-20°C to +120°C
LCR 3	16 bar	-20°C to +120°C	25 bar	-20°C to +120°C
LCRI, LCRN 3	16 bar	-20°C to +120°C	25 bar	-20°C to +120°C
LCR 4	16 bar	-20°C to +120°C	25 bar	-20°C to +120°C
LCRI, LCRN 4	16 bar	-20°C to +120°C	25 bar	-20°C to +120°C
LCR 5	16 bar	-20°C to +120°C	25 bar	-20°C to +120°C
LCRI, LCRN 5	16 bar	-20°C to +120°C	25 bar	-20°C to +120°C
LCR 10-1 to 10-16	-	-	16 bar	-20°C to +120°C
LCRI 10-1 to 10-16	-	-	16 bar	-20°C to +120°C
LCR, LCRI 10-17 to 10-22	-	-	25 bar	-20°C to +120°C
LCRN 10	-	-	25 bar	-20°C to +120°C
LCR, LCRI 15-1 to 15-10	-	-	16 bar	-20°C to +120°C
LCR, LCRI 15-12 to 15-17	-	-	25 bar	-20°C to +120°C
LCRN 15	-	-	25 bar	-20°C to +120°C
LCR, LCRI 20-1 to 20-10	-	-	16 bar	-20°C to +120°C
LCR, LCRI 20-12 to 20-17	-	-	25 bar	-20°C to +120°C
LCRN 20	-	-	25 bar	-20°C to +120°C
LCR, LCRI, LCRN 32-1-1 to 32-7	-	-	16 bar	-30°C to +120°C
LCR, LCRI, LCRN 32-8-2 to 32-14	-	-	30 bar	-30°C to +120°C
LCR, LCRI, LCRN 45-1-1 to 45-5	-	-	16 bar	-30°C to +120°C
LCR, LCRI, LCRN 45-6-2 to 45-11	-	-	30 bar	-30°C to +120°C
LCR, LCRI, LCRN 45-12-2 to 45-13-2	-	-	33 bar	-30°C to +120°C
LCR, LCRI, LCRN 64-1-1 to 64-5	-	-	16 bar	-30°C to +120°C
LCR, LCRI, LCRN 64-6-2 to 64-8-1	-	-	30 bar	-30°C to +120°C
LCR, LCRI, LCRN 90-1-1 to 90-4	-	-	16 bar	-30°C to +120°C
LCR, LCRI, LCRN 90-5-2 to 90-6	-	-	30 bar	-30°C to +120°C
LCR, LCRN 120	-	-	30 bar	-30°C to +120°C
LCR, LCRN 150	-	-	30 bar	-30°C to +120°C

Operating range of the shaft seal

The operating range of the shaft seal depends on operating pressure, pump type, type of shaft seal and liquid temperature. The following curves apply to clean water and water with anti-freeze liquids.

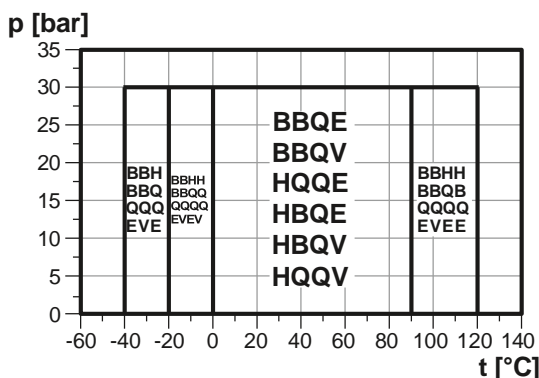

Shaft seal	Description	Max. Temperature range [°C]
BBQE	Bellow type shaft seal, Carbon/Sic/SS 316/EPDM	-40°C to +120°C
BBQV	Bellow type shaft seal, Carbon/Sic/SS 316/FKM	-40°C to +120°C
HQQE	Cartridge type shaft seal, Sic/Sic/SS 316/EPDM	-40°C to +120°C
HBQE	Cartridge type shaft seal, Carbon/Sic/SS 316/EPDM	0°C to +120°C
HBQV	Cartridge type shaft seal, Carbon/Sic/SS 316/FKM	0°C to +90°C
HQQV	Cartridge type shaft seal, Sic/Sic/SS 316/FKM	-20°C to +90°C

Fig. 5 Operating range of standard shaft seals

Operating and inlet pressures

LCR, LCRI, LCRN

Vertical multistage centrifugal pumps

Maximum inlet pressure

The following table shows the maximum permissible inlet pressure. However the current inlet pressure + the pressure against a closed valve **must** always be lower than the maximum permissible operating pressure.

If the maximum permissible operating pressure is exceeded, the conical bearing in the motor may be damaged and the life of the shaft seal reduced.

LCR, LCRI, LCRN 1s 1s-2 to 1s-36	10 bar
LCR, LCRI, LCRN 1 1-2 to 1-36	10 bar
LCR, LCRI, LCRN 2 2-2 to 2-11 2-13 to 2-26	10 bar 15 bar
LCR, LCRI, LCRN 3 3-2 to 3-29 3-31 to 3-36	10 bar 15 bar
LCR, LCRI, LCRN 4 4-2 to 4-10 4-12 to 4-22	10 bar 15 bar
LCR, LCRI, LCRN 5 5-2 to 5-16 5-18 to 5-36	10 bar 15 bar
LCR, LCRI, LCRN 10 10-1 to 10-6 10-7 to 10-22	8 bar 10 bar
LCR, LCRI, LCRN 15 15-1 to 15-3 15-4 to 15-17	8 bar 10 bar
LCR, LCRI, LCRN 20 20-1 to 20-3 20-4 to 20-17	8 bar 10 bar
LCR, LCRI, LCRN 32 32-1-1 to 32-4 32-5-2 to 32-10 32-11 to 32-14	4 bar 10 bar 15 bar
LCR, LCRI, LCRN 45 45-1-1 to 45-2 45-3-2 to 45-5 45-6-2 to 45-13-2	4 bar 10 bar 15 bar
LCR, LCRI, LCRN 64 64-1-1 to 64-2-2 64-2-1 to 64-4-2 64-4-1 to 64-8-1	4 bar 10 bar 15 bar
LCR, LCRI, LCRN 90 90-1-1 to 90-1 90-2-2 to 90-3-2 90-3 to 90-6	4 bar 10 bar 15 bar
LCR, LCRN 120 120-1 to 120-2-1 120-2 to 120-5-1 120-6-1 to 120-7	10 bar 15 bar 20 bar
LCR, LCRN 150 150-1-1 to 150-1 150-2-1 to 150-4-1 150-5-2 to 150-6	10 bar 15 bar 20 bar

Examples of operating and inlet pressures

The values for operating and inlet pressures shown in the table must not be considered individually but must always be compared, see the following examples:

Example 1:

The following pump type has been selected:
LCR 3-17 A-A

Max. operating pressure: **16 bar**
Max. inlet pressure: **10 bar**

Discharge pressure against a closed valve: **11.3 bar**, see page 35.

This pump is **not** allowed to start at an inlet pressure of 10 bar, but at an inlet pressure of $16.0 - 11.3 = 4.7$ bar.

Example 2:

The following pump type has been selected:
LCR 15-2 F-A

Max. operating pressure: **16 bar**
Max. inlet pressure: **8.0 bar**

Discharge pressure against a closed valve: **2.8 bar**, see page 51.

This pump is allowed to start at an inlet pressure of 8.0 bar, as the discharge pressure against a closed valve is only 2.8 bar, which results in an operating pressure of $8.0 + 2.8 = 10.8$ bar. On the contrary, the max operating pressure of this pump is limited to 16.0 bar, as a higher operating pressure will require an inlet pressure of more than 8.0 bar.

Selection and sizing

Vertical multistage centrifugal pumps

Selection of pumps

Selection of pumps should be based on:

- The duty point of pump (see section A)
- Dimensional data such as pressure loss as a result of height differences, friction loss in the pipework, pump efficiency etc. (see section B)
- Pump materials (see section C)
- Pump connections (see section D)
- Shaft seal (see section E)

A. Duty point of the pump

From a duty point it is possible to select a pump on the basis of the curve charts shown in "Performance curves" from page 23.

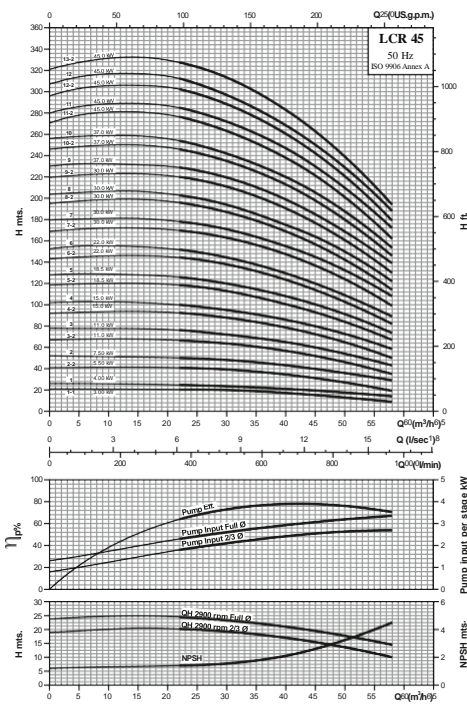

Fig. 6 Example of curve chart

B. Dimensional data

When sizing a pump, take the following factors into account:

- Required flow and pressure at the pump delivery point.
- Pressure loss as a result of height differences (H_s).
- Friction loss in the pipe work (H_f).

It may be necessary to account for pressure loss in connection with long pipes, bends or valves, etc.

- Best efficiency at the estimated duty point.
- NPSH value.

For calculation of the NPSH value see "Minimum inlet pressure - NPSH", page 18.

LCR, LCRI, LCRN

Pump efficiency

Before determining the best efficiency point, the operation pattern of the pump needs to be identified.

Is the pump expected to operate at the **same** duty point, then select a LCR pump which is operating at a duty point corresponding with the best efficiency of the pump.

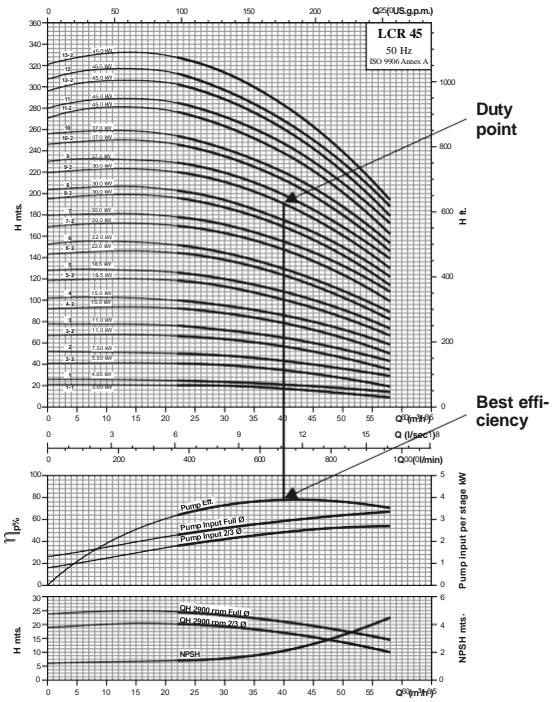

Fig. 7 Example of LCR pump's duty point

As the pump is sized on the basis of highest possible flow, it is important always to have the duty point to the right on the efficiency curve (η) in order to keep efficiency high when the flow drops.



Fig. 8 Best efficiency

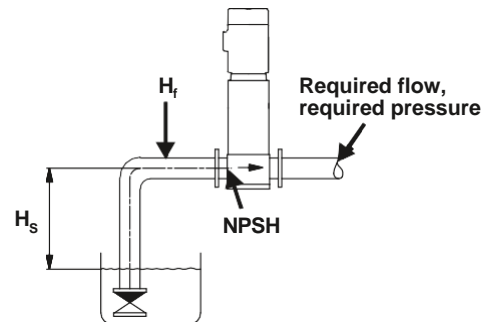

Fig. 9 Dimensional data

Selection and sizing

Vertical multistage centrifugal pumps

C. Pump material

The material variant (LCR, LCRI, LCRN) should be selected based on the liquid to be pumped. The product range covers the following three basic types.

- The LCR, LCRI pump types are suitable for clean, non-aggressive liquids such as potable water, oils etc.
- The LCRN pump type is suitable for industrial liquids and acids.

D. Pump connections

Selection of pump connection depends on the rated pressure and pipework. To meet any requirement the LCR, LCRI and LCRN pumps offer a wide range of flexible connection such as:

- Oval flange (BSP) (for LCR 1s, 1, 2, 3, 5)
- DIN flange (for LCR, LCRI, LCRN 1s, 1, 2, 3, 5, 10, 15, 20, 32, 45, 64, 90, 120, 150)
- Oval flange (NPT) on request
- Other connection on request

E. Shaft seal

As standard, the LCR range is fitted with a Lubi shaft seal suitable for the most common applications.

The following key parameters **must** be taken into account, when selecting the shaft seal:

- Type of pumped liquid
- Liquid temperature and
- Maximum pressure.

Lubi offers a wide range of shaft seal variants to meet specific demands.

Inlet pressure and operating pressure

The limit values stated on page 14 and page 15 must **not** be exceeded as regards....

- Maximum inlet pressure and
- Maximum operating pressure.

LCR, LCRI, LCRN

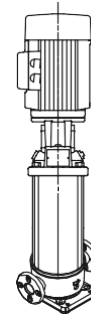

Fig. 10 LCR pump

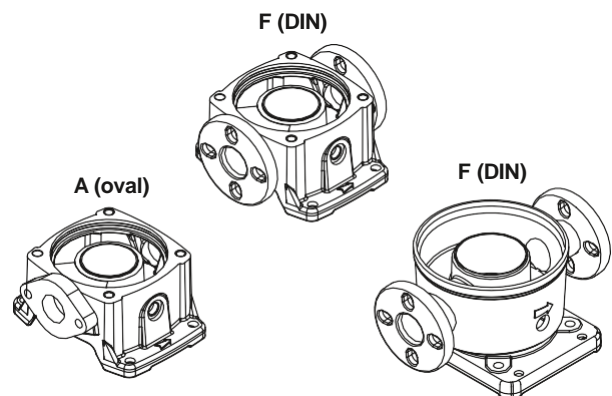

Fig. 11 Pump connections

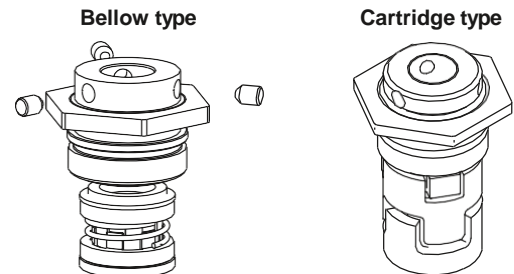

Fig. 12 Shaft seal

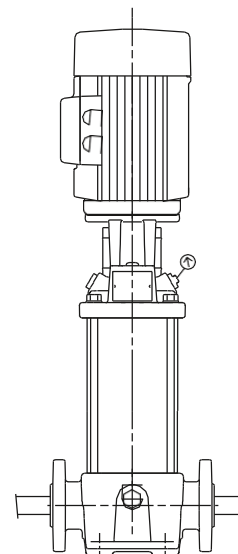

Fig. 13 Inlet and operating pressure

Selection and sizing

LCR, LCRI, LCRN

Vertical multistage centrifugal pumps

Minimum inlet pressure – NPSH

Calculation of the inlet pressure “H” is recommended when....

- The liquid temperature is high,
- The flow is significantly higher than the rated flow,
- Water is drawn from depths,
- Water is drawn through long pipes,
- Inlet conditions are poor.

To avoid cavitation, make sure that there is a minimum pressure on the suction side of the pump. The maximum suction lift “H” in metres head can be calculated as follows.

$$H = p_b \times 10.2 - \text{NPSH} - H_f - H_v - H_s$$

p_b = Barometric pressure in bar.
 (Barometric pressure can be set to 1 bar).
 In closed systems, p_b indicates the system pressure in bar.

NPSH = Net Positive Suction Head in metres head.
 (To be read from the NPSH curve at the highest flow the pump will be delivering).

H_f = Friction loss in suction pipe in metres head.
 (At the highest flow the pump will be delivering).

H_v = Vapour pressure in metres head.
 (To be read from the vapour pressure scale.
 “ H_v ” depends on the liquid temperature “ T_m ”).

H_s = Safety margin = minimum 0.5 metres head.

If the “H” calculated is positive, the pump can operate at a suction lift of maximum “H” metres head.

If the “H” calculated is negative, an inlet pressure of minimum “H” metres head is required.

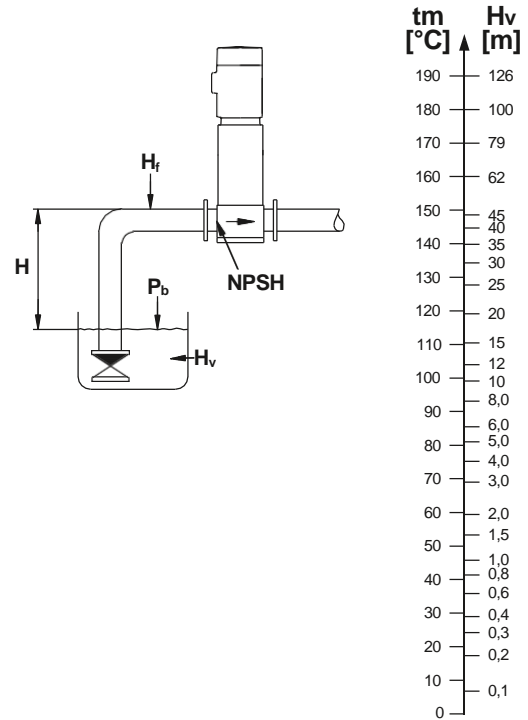

Fig. 14 Minimum inlet pressure - NPSH

Note: In order to avoid cavitation **never** select a pump with a duty point too far to the right on the NPSH curve.

Always check, the NPSH value of the pump at the highest possible flow.

Selection and sizing

LCR, LCRI, LCRN

Vertical multistage centrifugal pumps

How to read the curve charts

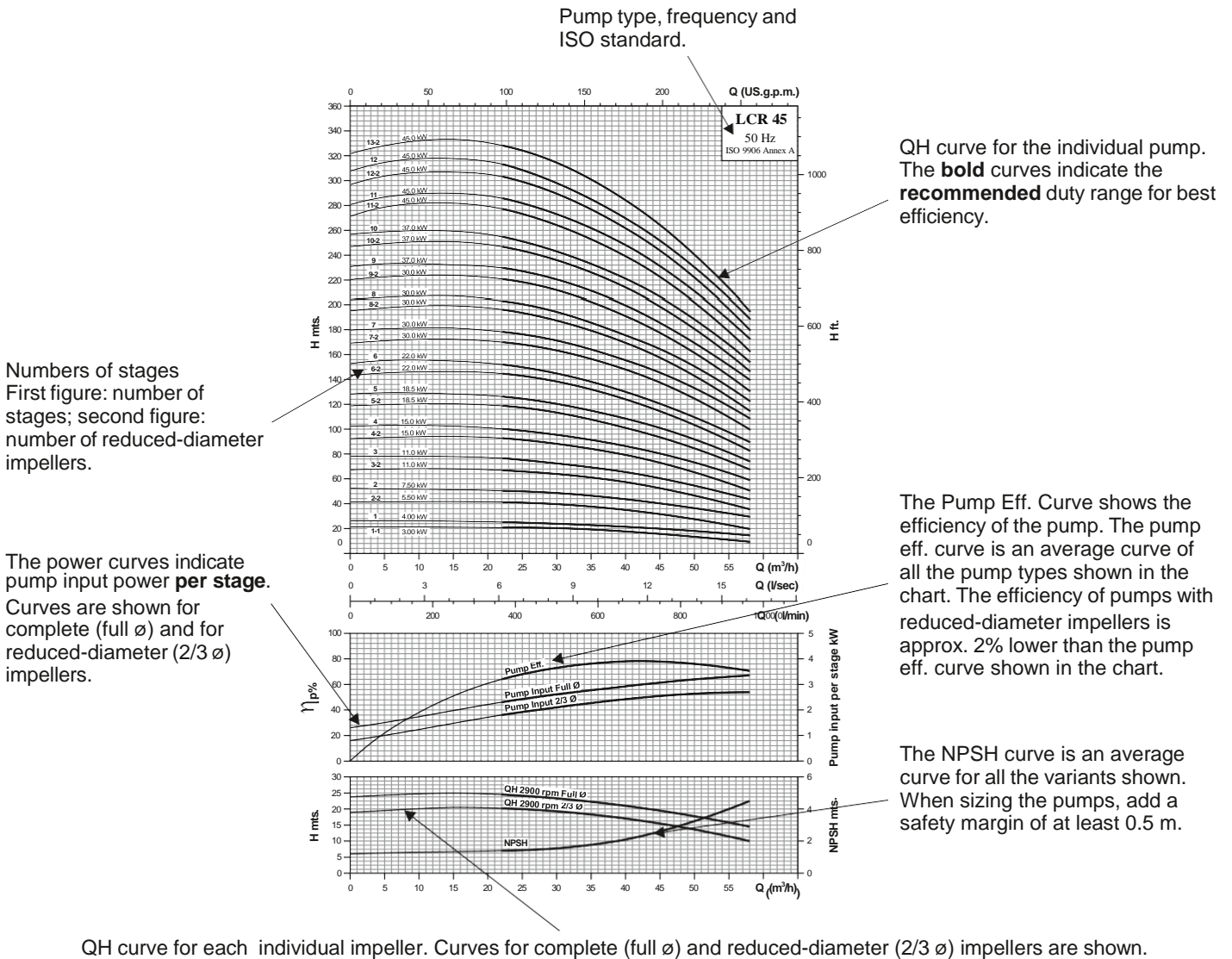

Fig. 15 How to read the curve charts

Guidelines to performance curves

The guidelines below apply to the curves shown on the following pages:

- Tolerances to ISO 9906, Annex A, if indicated.
- The motors used for the measurements are standard motors.
- Measurements have been made with airless water at a temperature of 20° C.
- The curves apply to a kinematic viscosity of $\nu = 1 \text{ mm}^2/\text{s}$ (1 cSt).
- Due to the risk of overheating, the pumps should not be used at a flow below the minimum flow rate.
- The QH curves apply to a rated motor speed of 2900 min^{-1} . All curves are based on current motor speeds.

The curve below shows the minimum flow rate as a percentage of the nominal flow rate in relation to the liquid temperature.

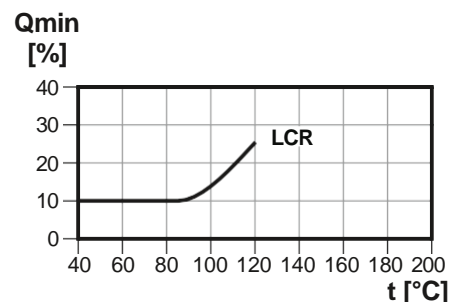

Fig. 16 Minimum flow rate

Pumped liquids

LCR, LCRI, LCRN

Vertical multistage centrifugal pumps

Pumped liquids

Thin non-explosive liquids and not containing solid particles or fibers are suitable. The liquid must also not chemically attack the pump materials.

When pumping liquids with a density and/or viscosity higher than that of water, oversized motors must be used, if required.

Whether a pump is suitable for a particular liquid depends on a number of factors of which the most important are the chloride content, pH value, temperature and content of chemicals, oils etc.

Please note that aggressive liquids (e.g. sea water and some acids) may attack or dissolve the protective oxide film of the stainless steel and thus cause corrosion.

The LCR, LCRI, LCRN pump types are suitable for the following liquids.

LCR, LCRI

- Non-corrosive liquids.
- For liquid transfer, circulation and pressure boosting of cold or hot clean water.

LCRN

- Industrial liquids.

In systems where all parts in contact with the liquid must be made of high-grade stainless steel.

Motor Data

LCR, LCRI, LCRN

Vertical multistage centrifugal pumps

Standard motor for LCR, LCRI, LCRN 50 Hz

Type	Motor H.P	Motor kW	Phase	Frame size	Standard voltage [V]	I _{1n} [A]	Cos \varnothing_{1n}	η [%]	I _{start}
MCR500052211	0.50	0.37	1	71	220-240*	2.6/2.4	0.98	62.0	13/12
MCR500072211	0.75	0.55	1	71	220-240*	4.6/4.5	0.98	64.0	23/22
MCR500102211	1.00	0.75	1	80	220-240*	5.1/4.8	0.97	68.0	28/26
MCR500152211	1.50	1.10	1	80	220-240*	6.85/6.7	0.97	73.0	36.5/35
MCR500202211	2.00	1.50	1	90	220-240*	9.1/8.3	0.98	76.0	46/42
MCR500302211	3.00	2.20	1	90	220-240*	12.5/11.7	0.98	80.0	63/59
MCR500058231	0.50	0.37	3	71	220-240 Δ /(380-415Y*)	1.46/0.85	0.87	70.0	7.3/4.3
MCR500078231	0.75	0.55	3	71	220-240 Δ /(380-415Y*)	2.2/1.5	0.91	70.0	11/7.5
MCR500108231	1.00	0.75	3	80	220-240 Δ /(380-415Y*)	2.6/1.6	0.90	77.0	15.6/9.6
MCR500158231	1.50	1.10	3	80	220-240 Δ /(380-415Y*)	3.9/2.3	0.90	76.2	23.4/13.8
MCR500208231	2.00	1.50	3	90	220-240 Δ /(380-415Y*)	5.1/3.0	0.91	78.5	30.6/18
MCR500308231	3.00	2.20	3	90	220-240 Δ /(380-415Y*)	7.6/4.5	0.89	81.0	45.6/27
MCR500408231	4.00	3.00	3	100	220-240 Δ /(380-415Y*)	9.9/5.8	0.88	83.0	59.4/34.8
MCR500558231	5.50	4.00	3	112	220-240 Δ /(380-415Y*)	13.9/8.1	0.82	84.0	83.4/48.6
MCR500754231	7.50	5.50	3	132	380-415 Δ *	11.2/10.6	0.91	85.7	67.2/63.6
MCR501004231	10.0	7.50	3	132	380-415 Δ *	14.8/14.5	0.82	87.0	96.2/94.3
MCR501504231	15.0	11.0	3	160	380-415 Δ *	20.8/19.0	0.89	90.5	135.2/123.5
MCR502004231	20.0	15.0	3	160	380-415 Δ *	28.5/26	0.88	91.0	185.3/169
MCR502504231	25.0	18.5	3	160	380-415 Δ *	35/32	0.88	92.0	245/224
MCR503004231	30.0	22.0	3	180	380-415 Δ *	44/40	0.83	92.0	308/280
MCR504004231	40.0	30.0	3	200	380-415 Δ *	54.5/50	0.90	93.0	381/350
MCR505004231	50.0	37.0	3	200	380-415 Δ *	67/61	0.90	93.0	469/427
MCR506004231	60.0	45.0	3	225	380-415 Δ *	78/71	0.94	93.5	546/497
MCR507504231	75.0	55.0	3	250	380-415 Δ *	95/88	0.93	93.5	665/616
MCR510004231	100.0	75.0	3	280	380-415 Δ *	135/123	0.90	94.0	945/861

- (*) Standard voltage

- Special voltages available on request.

Technical Data

Vertical multistage centrifugal pumps

LCR 1s

Performance Chart

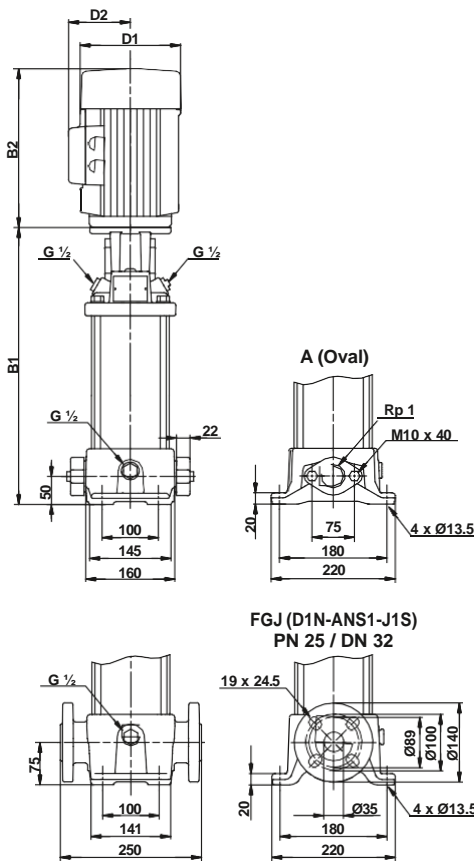

Pump Type	H.P.	kW	Q 1/min m ³ /h	n = 2900 rpm					
				8.3	10.0	11.7	13.3	15.0	16.7
				0.5	0.6	0.7	0.8	0.9	1.0
LCR 1s/2	0.50	0.37	H mts.	12	12	10	10	9	8
LCR 1s/3	0.50	0.37		17	16	15	14	13	12
LCR 1s/4	0.50	0.37		22	21	19	18	17	15
LCR 1s/5	0.50	0.37		27	26	25	23	21	19
LCR 1s/6	0.50	0.37		33	31	29	27	25	22
LCR 1s/7	0.50	0.37		38	36	34	31	29	26
LCR 1s/8	0.50	0.37		43	40	38	35	32	29
LCR 1s/9	0.50	0.37		48	46	42	40	36	33
LCR 1s/10	0.50	0.37		53	50	47	44	40	36
LCR 1s/11	0.50	0.37		58	56	52	48	44	39
LCR 1s/12	0.50	0.37		63	59	56	52	47	42
LCR 1s/13	0.50	0.37		68	64	60	56	51	46
LCR 1s/15	0.75	0.55		79	74	70	65	59	53
LCR 1s/17	0.75	0.55		88	83	78	72	66	59
LCR 1s/19	0.75	0.55		98	93	87	81	74	66
LCR 1s/21	1.00	0.75		110	104	98	91	83	75
LCR 1s/23	1.00	0.75		120	114	106	99	90	82
LCR 1s/25	1.00	0.75		130	122	115	106	97	87
LCR 1s/27	1.50	1.10		142	134	126	117	106	96
LCR 1s/30	1.50	1.10		157	149	140	130	118	106
LCR 1s/33	1.50	1.10		172	163	153	142	129	116
LCR 1s/36	1.50	1.10		187	176	165	153	140	125

Dimensions & Weights of LCR Pump

Pump type	Dimensions [mm]						Net weight [kg]		Gross weight [kg]		Gross volume [m ³]
	Oval flange		D1N flange		D1	D2	Oval flange	D1N flange	Oval flange	D1N flange	
	B1	B1+B2	B1	B1+B2							
LCR 1s/2	236	449	261	474	143	106	18.0	23.0	28.0	33.0	0.1030
LCR 1s/3	254	467	279	492	143	106	18.0	23.0	28.0	33.0	0.1030
LCR 1s/4	272	485	297	510	143	106	19.0	23.0	29.0	33.0	0.1030
LCR 1s/5	290	503	315	528	143	106	19.0	24.0	29.0	34.0	0.1030
LCR 1s/6	308	521	333	546	143	106	19.0	24.0	29.0	34.0	0.1030
LCR 1s/7	326	539	351	564	143	106	20.0	24.0	30.0	34.0	0.1030
LCR 1s/8	344	557	369	582	143	106	20.0	25.0	34.0	39.0	0.1428
LCR 1s/9	362	575	387	600	143	106	21.0	25.0	35.0	39.0	0.1428
LCR 1s/10	380	593	405	618	143	106	21.0	26.0	35.0	40.0	0.1428
LCR 1s/11	398	611	423	636	143	106	21.0	26.0	35.0	40.0	0.1428
LCR 1s/12	416	629	441	654	143	106	22.0	26.0	36.0	40.0	0.1428
LCR 1s/13	434	647	459	672	143	106	22.0	27.0	36.0	41.0	0.1428
LCR 1s/15	470	683	495	708	143	106	24.0	28.0	38.0	42.0	0.1428
LCR 1s/17	506	719	531	744	143	106	25.0	29.0	39.0	43.0	0.1428
LCR 1s/19	542	755	567	780	143	106	25.0	30.0	43.0	48.0	0.1825
LCR 1s/21	584	848	609	873	160	113	28.0	32.0	46.0	50.0	0.1825
LCR 1s/23	620	884	645	909	160	113	29.0	33.0	47.0	51.0	0.1825
LCR 1s/25	656	920	681	945	160	113	29.0	34.0	47.0	52.0	0.1825
LCR 1s/27	692	956	717	981	160	113	32.0	37.0	50.0	55.0	0.1825
LCR 1s/30	-	-	771	1035	160	113	-	38.0	-	58.0	0.2064
LCR 1s/33	-	-	825	1089	160	113	-	39.0	-	59.0	0.2064
LCR 1s/36	-	-	879	1143	160	113	-	41.0	-	61.0	0.2064

Performance Curves

Vertical multistage centrifugal pumps

LCR 1s

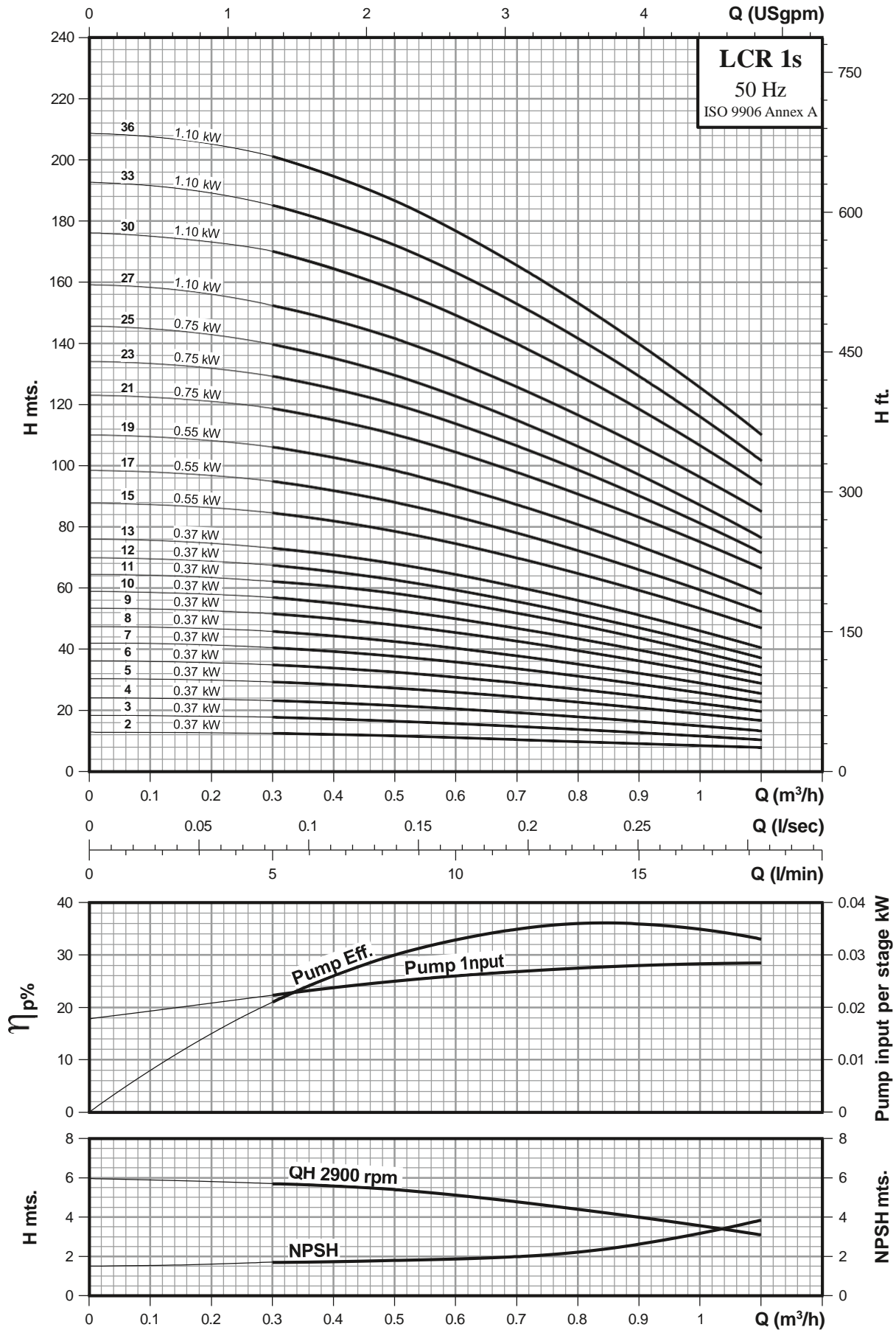

Technical Data

Vertical multistage centrifugal pumps

LCR1, LCRN 1s

Performance Chart

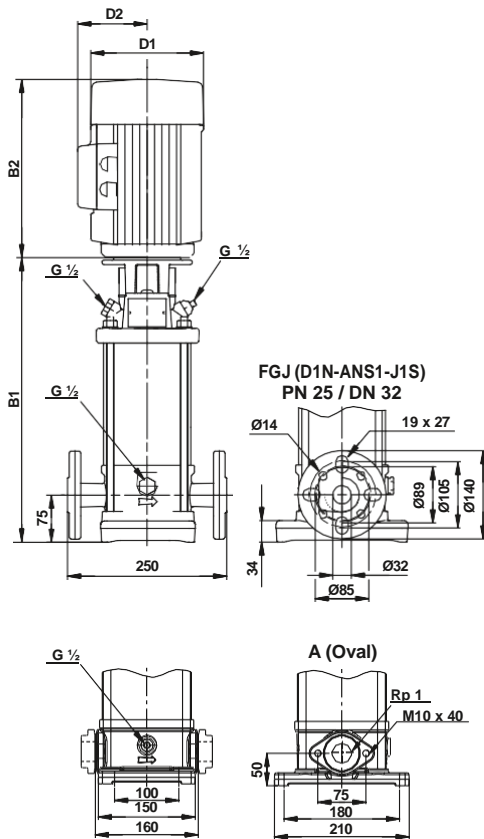

Pump Type	H.P.	kW	Q	n = 2900 rpm						
				1/min	8.3	10.0	11.7	13.3	15.0	16.7
				m ³ /h	0.5	0.6	0.7	0.8	0.9	1.0
LCR1, LCRN 1s/2	0.50	0.37	H mts.	12	12	10	10	9	8	
LCR1, LCRN 1s/3	0.50	0.37		17	16	15	14	13	12	
LCR1, LCRN 1s/4	0.50	0.37		22	21	19	18	17	15	
LCR1, LCRN 1s/5	0.50	0.37		27	26	25	23	21	19	
LCR1, LCRN 1s/6	0.50	0.37		33	31	29	27	25	22	
LCR1, LCRN 1s/7	0.50	0.37		38	36	34	31	29	26	
LCR1, LCRN 1s/8	0.50	0.37		43	40	38	35	32	29	
LCR1, LCRN 1s/9	0.50	0.37		48	46	42	40	36	33	
LCR1, LCRN 1s/10	0.50	0.37		53	50	47	44	40	36	
LCR1, LCRN 1s/11	0.50	0.37		58	56	52	48	44	39	
LCR1, LCRN 1s/12	0.50	0.37		63	59	56	52	47	42	
LCR1, LCRN 1s/13	0.50	0.37		68	64	60	56	51	46	
LCR1, LCRN 1s/15	0.75	0.55		79	74	70	65	59	53	
LCR1, LCRN 1s/17	0.75	0.55		88	83	78	72	66	59	
LCR1, LCRN 1s/19	0.75	0.55		98	93	87	81	74	66	
LCR1, LCRN 1s/21	1.00	0.75		110	104	98	91	83	75	
LCR1, LCRN 1s/23	1.00	0.75		120	114	106	99	90	82	
LCR1, LCRN 1s/25	1.00	0.75		130	122	115	106	97	87	
LCR1, LCRN 1s/27	1.50	1.10		142	134	126	117	106	96	
LCR1, LCRN 1s/30	1.50	1.10		157	149	140	130	118	106	
LCR1, LCRN 1s/33	1.50	1.10		172	163	153	142	129	116	
LCR1, LCRN 1s/36	1.50	1.10		187	176	165	153	140	125	

Dimensions & Weights of LCR1, LCRN Pump

Pump type	Dimensions [mm]						Net weight [kg]	Gross weight [kg]	Gross volume [m ³]
	Oval flange		D1N flange		D1	D2			
	B1	B1+B2	B1	B1+B2					
LCR1, LCRN 1s/2	239	452	264	477	143	106	20.0	30.0	0.1030
LCR1, LCRN 1s/3	257	470	282	495	143	106	21.0	31.0	0.1030
LCR1, LCRN 1s/4	275	488	300	513	143	106	21.0	31.0	0.1030
LCR1, LCRN 1s/5	293	506	318	531	143	106	21.0	31.0	0.1030
LCR1, LCRN 1s/6	311	524	336	549	143	106	22.0	32.0	0.1030
LCR1, LCRN 1s/7	329	542	354	567	143	106	22.0	32.0	0.1030
LCR1, LCRN 1s/8	347	560	372	585	143	106	23.0	37.0	0.1428
LCR1, LCRN 1s/9	365	578	390	603	143	106	23.0	37.0	0.1428
LCR1, LCRN 1s/10	383	596	408	621	143	106	23.0	37.0	0.1428
LCR1, LCRN 1s/11	401	614	426	639	143	106	24.0	38.0	0.1428
LCR1, LCRN 1s/12	419	632	444	657	143	106	24.0	38.0	0.1428
LCR1, LCRN 1s/13	437	650	462	675	143	106	25.0	39.0	0.1428
LCR1, LCRN 1s/15	473	686	498	711	143	106	26.0	40.0	0.1428
LCR1, LCRN 1s/17	509	722	534	747	143	106	27.0	41.0	0.1428
LCR1, LCRN 1s/19	545	758	570	783	143	106	28.0	46.0	0.1825
LCR1, LCRN 1s/21	587	851	612	876	160	113	31.0	49.0	0.1825
LCR1, LCRN 1s/23	623	887	648	912	160	113	31.0	49.0	0.1825
LCR1, LCRN 1s/25	659	923	684	948	160	113	32.0	50.0	0.1825
LCR1, LCRN 1s/27	695	959	720	984	160	113	35.0	53.0	0.1825
LCR1, LCRN 1s/30	749	1013	774	1038	160	113	36.0	56.0	0.2064
LCR1, LCRN 1s/33	803	1067	828	1092	160	113	37.0	57.0	0.2064
LCR1, LCRN 1s/36	857	1121	882	1146	160	113	39.0	59.0	0.2064

Performance Curves

Vertical multistage centrifugal pumps

LCR1, LCRN 1s

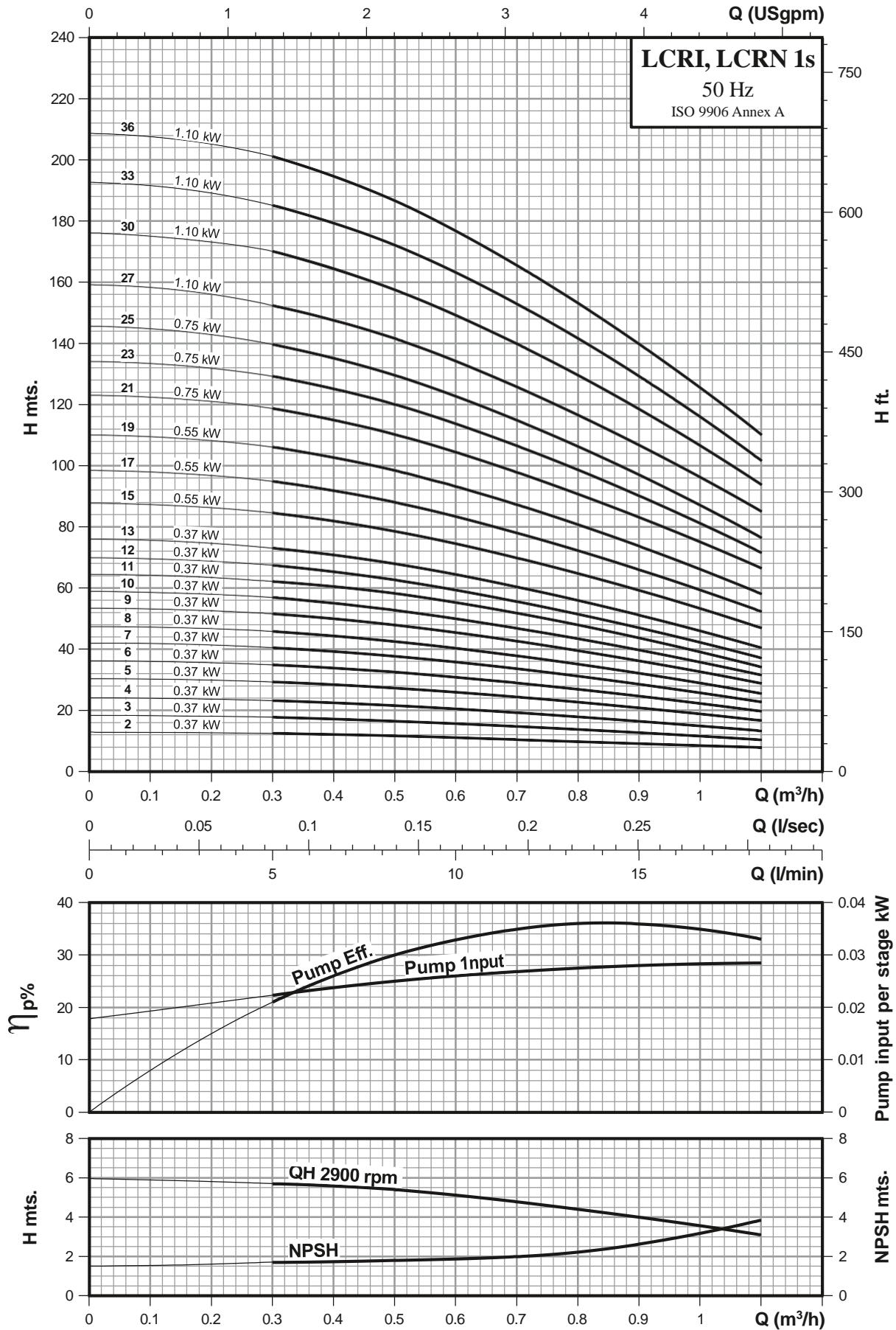

Technical Data

Vertical multistage centrifugal pumps

LCR 1

Performance Chart

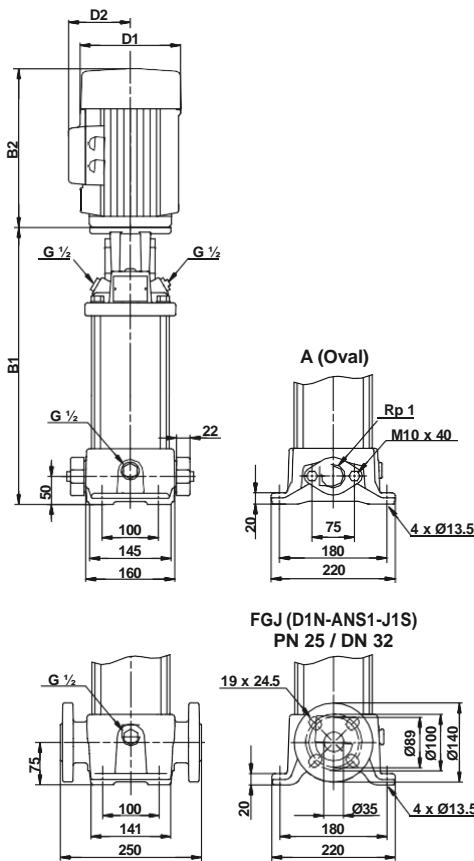

Pump Type	H.P.	kW	Q 1/min m³/h	n = 2900 rpm					
				16.7	23.3	26.7	30.0	33.3	36.7
				1.0	1.4	1.6	1.8	2.0	2.2
LCR 1/2	0.50	0.37	H mts.	12	11	11	10	9	9
LCR 1/3	0.50	0.37		18	17	16	15	13	12
LCR 1/4	0.50	0.37		24	22	21	19	17	15
LCR 1/5	0.50	0.37		30	27	26	24	22	19
LCR 1/6	0.50	0.37		35	33	31	29	26	23
LCR 1/7	0.50	0.37		41	38	36	33	30	26
LCR 1/8	0.75	0.55		47	44	41	38	34	30
LCR 1/9	0.75	0.55		53	49	46	43	38	34
LCR 1/10	0.75	0.55		58	54	50	47	42	36
LCR 1/11	0.75	0.55		63	59	55	51	46	40
LCR 1/12	1.00	0.75		69	64	60	56	50	44
LCR 1/13	1.00	0.75		75	70	65	60	54	47
LCR 1/15	1.00	0.75		86	80	75	70	62	54
LCR 1/17	1.50	1.10		99	91	86	80	71	62
LCR 1/19	1.50	1.10		111	102	95	89	79	69
LCR 1/21	1.50	1.10		120	111	104	97	86	75
LCR 1/23	1.50	1.10		131	120	112	104	92	80
LCR 1/25	2.00	1.50		147	136	128	119	106	93
LCR 1/27	2.00	1.50		159	148	138	129	115	101
LCR 1/30	2.00	1.50		175	163	152	142	127	111
LCR 1/33	3.00	2.20		194	180	169	157	141	124
LCR 1/36	3.00	2.20		212	197	185	173	155	136

Dimensions & Weights of LCR Pump

Pump type	Dimensions [mm]						Net weight [kg]		Gross weight [kg]		Gross volume [m³]
	Oval flange		D1N flange		D1	D2	Oval flange	D1N flange	Oval flange	D1N flange	
	B1	B1+B2	B1	B1+B2							
LCR 1/2	236	449	261	474	143	106	18.0	23.0	28.0	33.0	0.1030
LCR 1/3	254	467	279	492	143	106	18.0	23.0	28.0	33.0	0.1030
LCR 1/4	272	485	297	510	143	106	19.0	23.0	29.0	33.0	0.1030
LCR 1/5	290	503	315	528	143	106	19.0	24.0	29.0	34.0	0.1030
LCR 1/6	308	521	333	546	143	106	20.0	24.0	30.0	34.0	0.1030
LCR 1/7	326	539	351	564	143	106	20.0	25.0	30.0	35.0	0.1030
LCR 1/8	344	557	369	582	143	106	21.0	26.0	35.0	40.0	0.1428
LCR 1/9	362	575	387	600	143	106	21.0	26.0	35.0	40.0	0.1428
LCR 1/10	380	593	405	618	143	106	22.0	26.0	36.0	40.0	0.1428
LCR 1/11	398	611	423	636	143	106	22.0	27.0	36.0	41.0	0.1428
LCR 1/12	422	686	447	711	160	113	24.0	29.0	38.0	43.0	0.1428
LCR 1/13	440	704	465	729	160	113	25.0	29.0	39.0	43.0	0.1428
LCR 1/15	476	740	501	765	160	113	26.0	30.0	40.0	44.0	0.1428
LCR 1/17	512	776	537	801	160	113	29.0	33.0	43.0	47.0	0.1428
LCR 1/19	548	812	573	837	160	113	29.0	34.0	47.0	52.0	0.1825
LCR 1/21	584	848	609	873	160	113	30.0	35.0	48.0	53.0	0.1825
LCR 1/23	620	884	645	909	160	113	31.0	36.0	49.0	54.0	0.1825
LCR 1/25	-	-	697	975	165	130	-	44.0	-	62.0	0.1825
LCR 1/27	-	-	733	1011	165	130	-	44.0	-	62.0	0.1825
LCR 1/30	-	-	787	1065	165	130	-	46.0	-	66.0	0.2064
LCR 1/33	-	-	841	1119	165	130	-	47.0	-	67.0	0.2064
LCR 1/36	-	-	895	1173	165	130	-	49.0	-	69.0	0.2064

Performance Curves

Vertical multistage centrifugal pumps

LCR 1

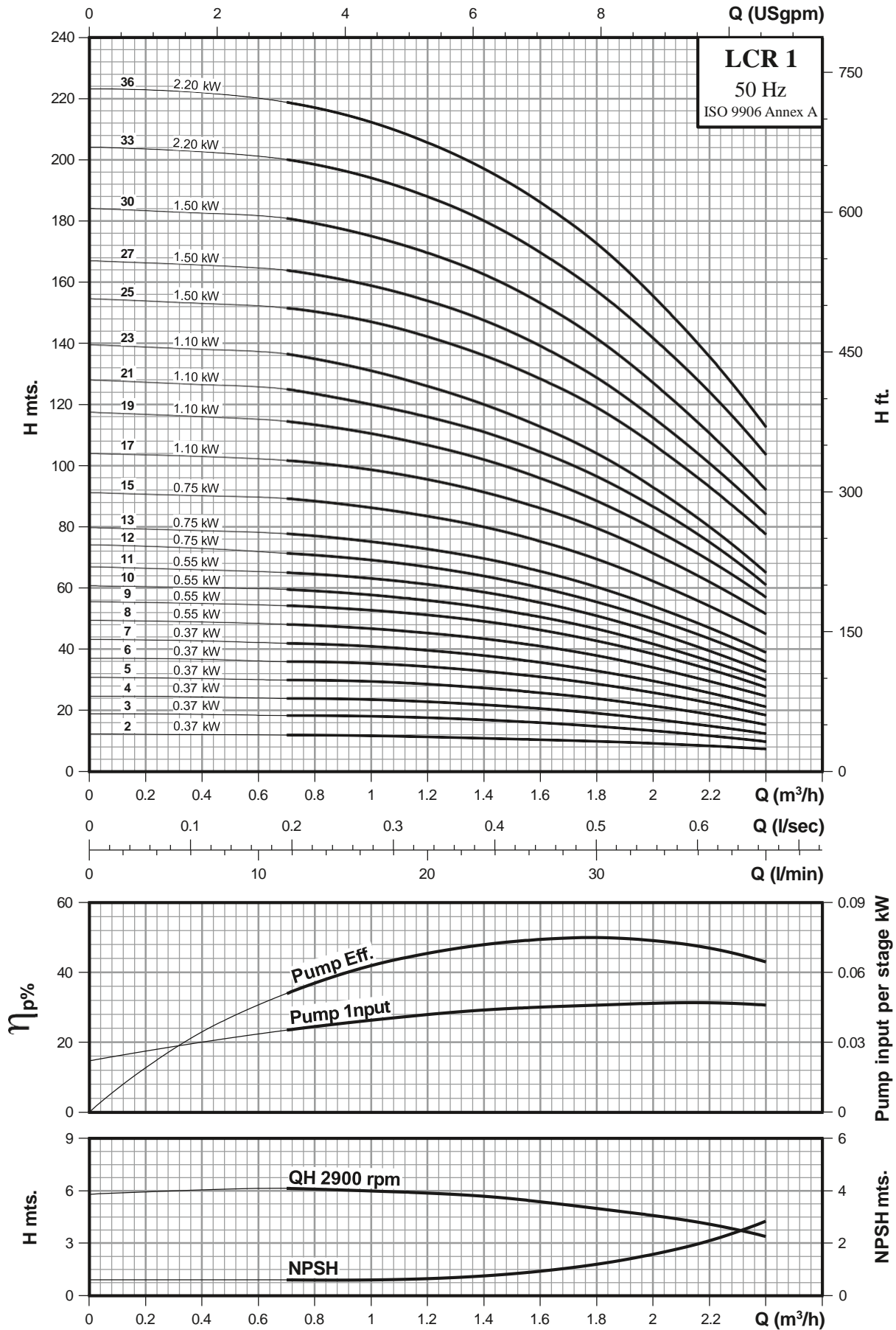

Technical Data

Vertical multistage centrifugal pumps

LCR1, LCRN 1

Performance Chart

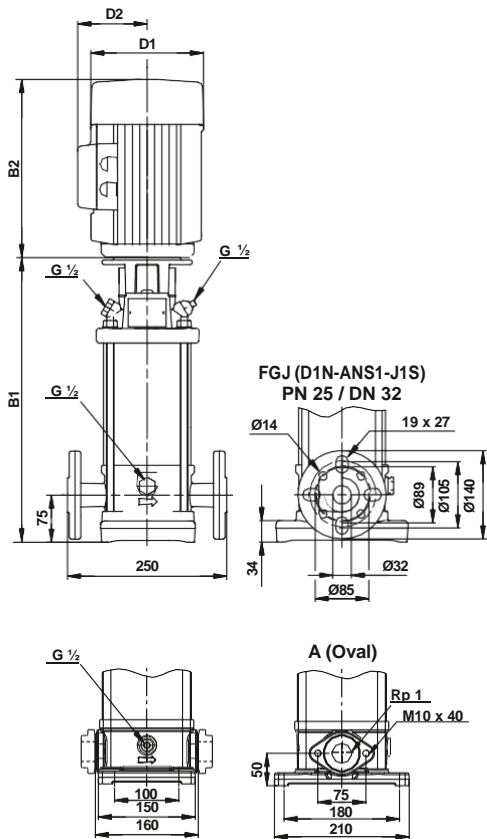

Pump Type	H.P.	kW	Q	n = 2900 rpm						
				1/min	16.7	23.3	26.7	30.0	33.3	36.7
				m ³ /h	1.0	1.4	1.6	1.8	2.0	2.2
LCR1, LCRN 1/2	0.50	0.37	H mts.	12	11	11	10	9	9	
LCR1, LCRN 1/3	0.50	0.37		18	17	16	15	13	12	
LCR1, LCRN 1/4	0.50	0.37		24	22	21	19	17	15	
LCR1, LCRN 1/5	0.50	0.37		30	27	26	24	22	19	
LCR1, LCRN 1/6	0.50	0.37		35	33	31	29	26	23	
LCR1, LCRN 1/7	0.50	0.37		41	38	36	33	30	26	
LCR1, LCRN 1/8	0.75	0.55		47	44	41	38	34	30	
LCR1, LCRN 1/9	0.75	0.55		53	49	46	43	38	34	
LCR1, LCRN 1/10	0.75	0.55		58	54	50	47	42	36	
LCR1, LCRN 1/11	0.75	0.55		63	59	55	51	46	40	
LCR1, LCRN 1/12	1.00	0.75		69	64	60	56	50	44	
LCR1, LCRN 1/13	1.00	0.75		75	70	65	60	54	47	
LCR1, LCRN 1/15	1.00	0.75		86	80	75	70	62	54	
LCR1, LCRN 1/17	1.50	1.10		99	91	86	80	71	62	
LCR1, LCRN 1/19	1.50	1.10		111	102	95	89	79	69	
LCR1, LCRN 1/21	1.50	1.10		120	111	104	97	86	75	
LCR1, LCRN 1/23	1.50	1.10		131	120	112	104	92	80	
LCR1, LCRN 1/25	2.00	1.50		147	136	128	119	106	93	
LCR1, LCRN 1/27	2.00	1.50		159	148	138	129	115	101	
LCR1, LCRN 1/30	2.00	1.50		175	163	152	142	127	111	
LCR1, LCRN 1/33	3.00	2.20		194	180	169	157	141	124	
LCR1, LCRN 1/36	3.00	2.20		212	197	185	173	155	136	

Dimensions & Weights of LCR1, LCRN Pump

Pump type	Dimensions [mm]						Net weight [kg]	Gross weight [kg]	Gross volume [m ³]
	Oval flange		D1N flange		D1	D2			
	B1	B1+B2	B1	B1+B2					
LCR1, LCRN 1/2	239	452	264	477	143	106	20.0	30.0	0.1030
LCR1, LCRN 1/3	257	470	282	495	143	106	21.0	31.0	0.1030
LCR1, LCRN 1/4	275	488	300	513	143	106	21.0	31.0	0.1030
LCR1, LCRN 1/5	293	506	318	531	143	106	21.0	31.0	0.1030
LCR1, LCRN 1/6	311	524	336	549	143	106	22.0	32.0	0.1030
LCR1, LCRN 1/7	329	542	354	567	143	106	22.0	32.0	0.1030
LCR1, LCRN 1/8	347	560	372	585	143	106	23.0	37.0	0.1428
LCR1, LCRN 1/9	365	578	390	603	143	106	24.0	38.0	0.1428
LCR1, LCRN 1/10	383	596	408	621	143	106	24.0	38.0	0.1428
LCR1, LCRN 1/11	401	614	426	639	143	106	24.0	38.0	0.1428
LCR1, LCRN 1/12	425	689	450	714	160	113	27.0	41.0	0.1428
LCR1, LCRN 1/13	443	707	468	732	160	113	28.0	42.0	0.1428
LCR1, LCRN 1/15	479	743	504	768	160	113	28.0	42.0	0.1428
LCR1, LCRN 1/17	515	779	540	804	160	113	31.0	45.0	0.1428
LCR1, LCRN 1/19	551	815	576	840	160	113	32.0	50.0	0.1825
LCR1, LCRN 1/21	587	851	612	876	160	113	33.0	51.0	0.1825
LCR1, LCRN 1/23	623	887	648	912	160	113	34.0	52.0	0.1825
LCR1, LCRN 1/25	675	953	700	978	165	130	41.0	59.0	0.1825
LCR1, LCRN 1/27	711	989	736	1014	165	130	42.0	60.0	0.1825
LCR1, LCRN 1/30	765	1043	790	1068	165	130	43.0	63.0	0.2064
LCR1, LCRN 1/33	819	1097	844	1122	165	130	45.0	65.0	0.2064
LCR1, LCRN 1/36	873	1151	898	1176	165	130	46.0	66.0	0.2064

Performance Curves

Vertical multistage centrifugal pumps

LCR1, LCRN 1

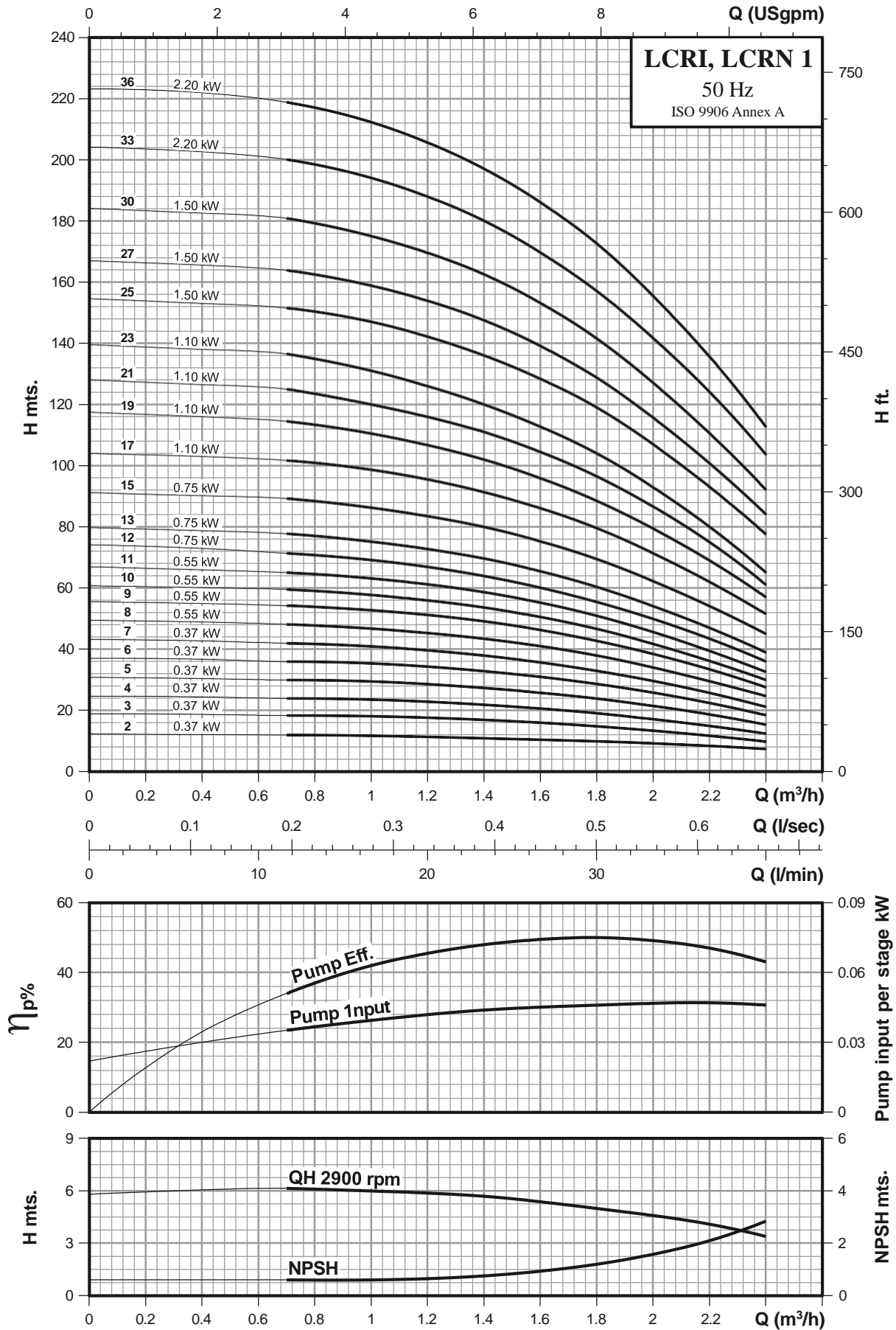

Technical Data

Vertical multistage centrifugal pumps

LCR 2

Performance Chart

Pump Type	H.P.	kW	Q l/min m ³ /h	n = 2900 rpm				
				16.7	26.7	38.3	50.0	58.3
				1.0	1.6	2.3	3.0	3.5
LCR 2/2	0.50	0.37	H mts.	18	17	15	12	9
LCR 2/3	0.50	0.37		27	25	22	17	12
LCR 2/4	0.75	0.55		37	34	29	23	18
LCR 2/5	0.75	0.55		45	42	36	28	21
LCR 2/6	1.00	0.75		55	50	43	34	25
LCR 2/7	1.00	0.75		63	58	49	39	29
LCR 2/9	1.50	1.10		81	74	64	51	39
LCR 2/11	1.50	1.10		98	89	76	60	45
LCR 2/13	2.00	1.50		117	107	93	74	56
LCR 2/15	2.00	1.50		134	122	105	83	62
LCR 2/18	3.00	2.20		163	150	130	104	79
LCR 2/22	3.00	2.20		197	180	155	123	93
LCR 2/26	4.00	3.00		236	217	187	149	113

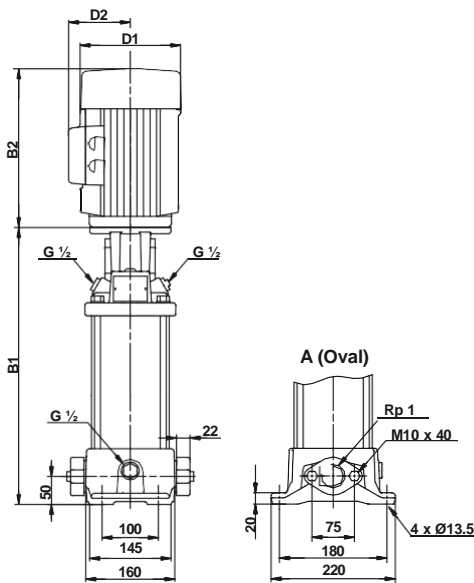

FGJ (DIN-ANSI-JIS)
PN 25 / DN 32

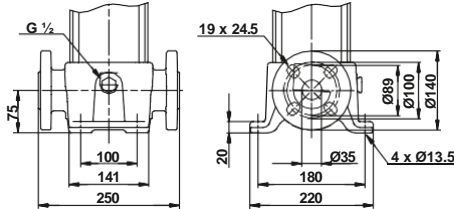

Dimensions & Weights of LCR Pump

Pump type	Dimensions [mm]						Net weight [kg]		Gross weight [kg]		Gross volume [m ³]
	Oval flange		DIN flange		D1	D2	Oval flange	DIN flange	Oval flange	DIN flange	
	B1	B1+B2	B1	B1+B2							
LCR 2/2	236	449	261	474	143	106	18.0	23.0	28.0	33.0	0.1030
LCR 2/3	254	467	279	492	143	106	18.0	23.0	28.0	33.0	0.1030
LCR 2/4	272	485	297	510	143	106	19.0	23.0	29.0	33.0	0.1030
LCR 2/5	290	503	315	528	143	106	19.0	24.0	29.0	34.0	0.1030
LCR 2/6	308	572	333	597	160	113	23.0	26.0	37.0	40.0	0.1428
LCR 2/7	326	590	351	615	160	113	23.0	27.0	37.0	41.0	0.1428
LCR 2/9	368	632	393	657	160	113	23.0	28.0	37.0	42.0	0.1428
LCR 2/11	404	668	429	693	160	113	26.0	31.0	40.0	45.0	0.1428
LCR 2/13	440	718	465	743	165	130	27.0	31.0	41.0	45.0	0.1428
LCR 2/15	476	754	501	779	165	130	36.0	40.0	50.0	54.0	0.1428
LCR 2/18	546	824	571	849	165	130	37.0	41.0	55.0	59.0	0.1825
LCR 2/22	618	896	643	921	165	130	39.0	43.0	57.0	61.0	0.1825
LCR 2/26	690	994	715	1019	194	140	45.0	49.0	74.0	78.0	0.2650

Performance Curves

Vertical multistage centrifugal pumps

LCR 2

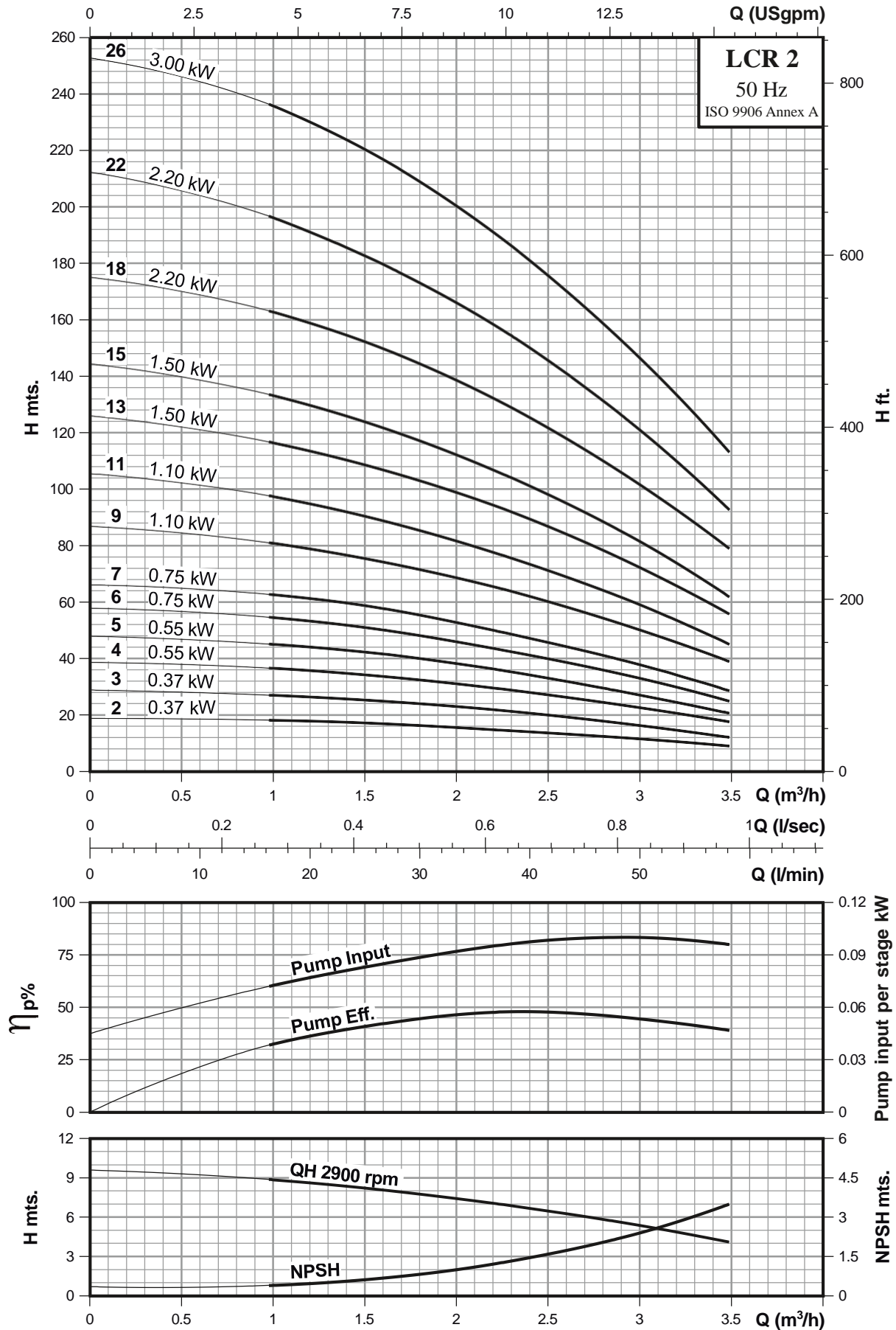

Technical Data

Vertical multistage centrifugal pumps

LCRI, LCRN 2

Performance Chart

Pump Type	H.P.	kW	Q l/min m ³ /h	n = 2900 rpm				
				16.7	26.7	38.3	50.0	58.3
				1.0	1.6	2.3	3.0	3.5
LCRI, LCRN 2/2	0.50	0.37	H mts.	18	17	15	12	9
LCRI, LCRN 2/3	0.50	0.37		27	25	22	17	12
LCRI, LCRN 2/4	0.75	0.55		37	34	29	23	18
LCRI, LCRN 2/5	0.75	0.55		45	42	36	28	21
LCRI, LCRN 2/6	1.00	0.75		55	50	43	34	25
LCRI, LCRN 2/7	1.00	0.75		63	58	49	39	29
LCRI, LCRN 2/9	1.50	1.10		81	74	64	51	39
LCRI, LCRN 2/11	1.50	1.10		98	89	76	60	45
LCRI, LCRN 2/13	2.00	1.50		117	107	93	74	56
LCRI, LCRN 2/15	2.00	1.50		134	122	105	83	62
LCRI, LCRN 2/18	3.00	2.20		163	150	130	104	79
LCRI, LCRN 2/22	3.00	2.20		197	180	155	123	93
LCRI, LCRN 2/26	4.00	3.00		236	217	187	149	113

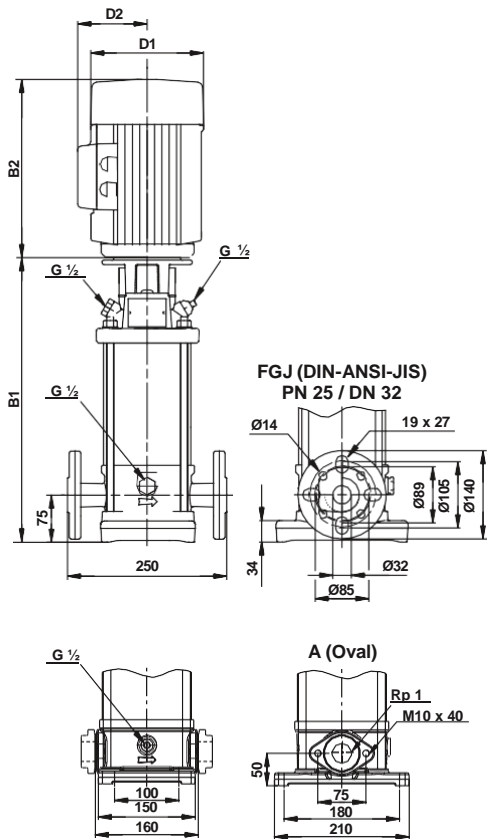

Dimensions & Weights of LCRI, LCRN Pump

Pump type	Dimensions [mm]						Net weight [kg]	Gross weight [kg]	Gross volume [m ³]
	Oval flange		DIN flange		D1	D2			
	B1	B1+B2	B1	B1+B2					
LCRI, LCRN 2/2	239	452	264	477	143	106	19.0	29.0	0.1030
LCRI, LCRN 2/3	257	470	282	495	143	106	19.0	29.0	0.1030
LCRI, LCRN 2/4	275	488	300	513	143	106	19.0	29.0	0.1030
LCRI, LCRN 2/5	293	506	318	531	143	106	20.0	30.0	0.1030
LCRI, LCRN 2/6	311	575	336	600	160	113	22.0	36.0	0.1428
LCRI, LCRN 2/7	329	593	354	618	160	113	24.0	38.0	0.1428
LCRI, LCRN 2/9	371	635	396	660	160	113	26.0	40.0	0.1428
LCRI, LCRN 2/11	407	671	432	696	160	113	27.0	41.0	0.1428
LCRI, LCRN 2/13	443	721	468	746	165	130	29.0	43.0	0.1428
LCRI, LCRN 2/15	479	757	504	782	165	130	35.0	49.0	0.1428
LCRI, LCRN 2/18	549	827	574	852	165	130	37.0	55.0	0.1825
LCRI, LCRN 2/22	621	899	646	924	165	130	39.0	57.0	0.1825
LCRI, LCRN 2/26	693	997	718	1022	194	140	46.0	72.0	0.2650

Performance Curves

Vertical multistage centrifugal pumps

LCRI, LCRN 2

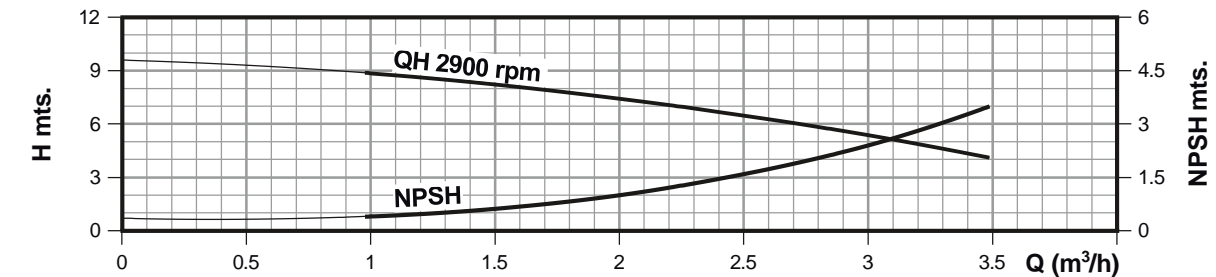
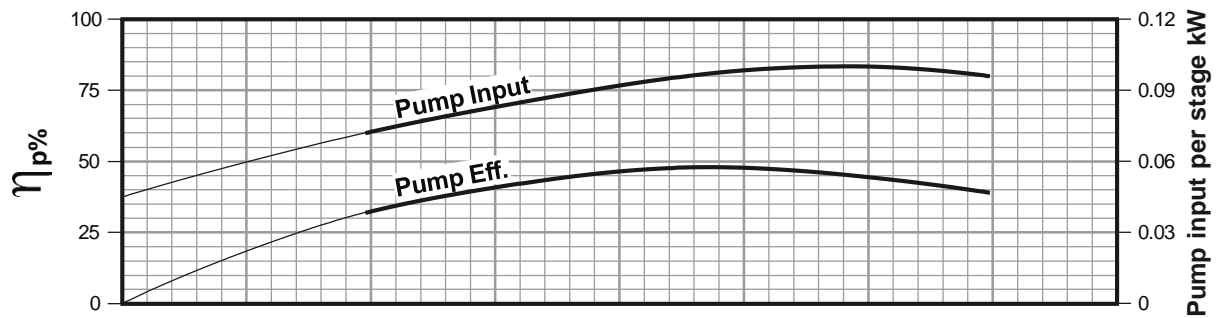
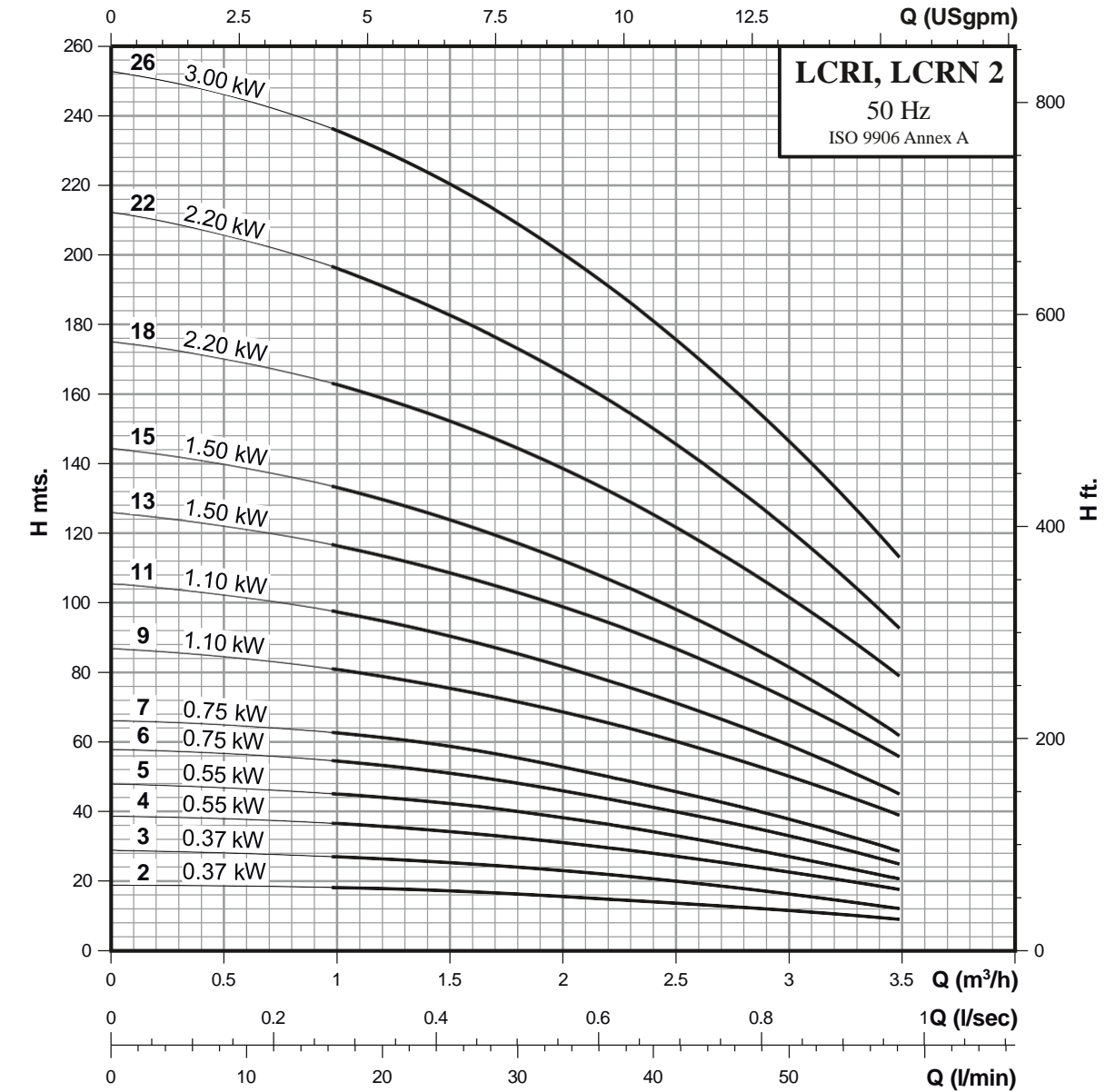

Technical Data

Vertical multistage centrifugal pumps

LCR 3

Performance Chart

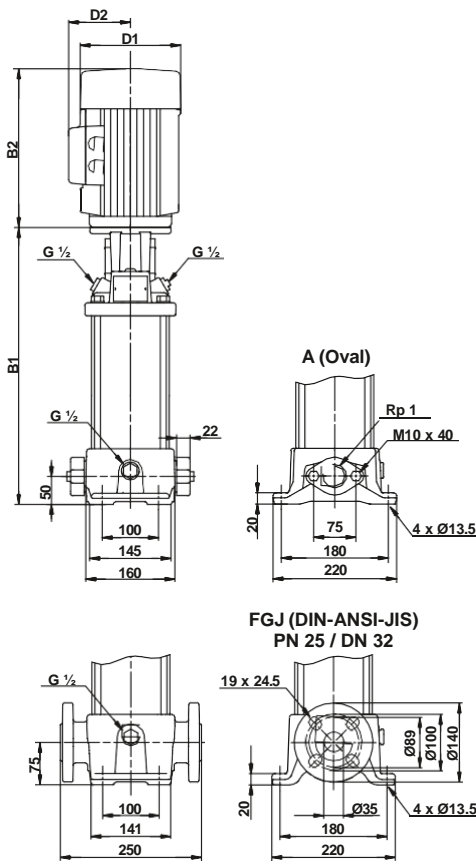

Pump Type	H.P.	kW	Q l/min m ³ /h	n = 2900 rpm					
				33.3	40.0	46.7	50.0	53.3	60.0
				2.0	2.4	2.8	3.0	3.2	3.6
LCR 3/2	0.50	0.37	H mts.	12	11	10	10	9	8
LCR 3/3	0.50	0.37		18	17	15	15	14	12
LCR 3/4	0.50	0.37		23	22	21	19	18	16
LCR 3/5	0.50	0.37		29	28	26	24	23	21
LCR 3/6	0.75	0.55		35	33	30	29	27	24
LCR 3/7	0.75	0.55		41	38	36	34	33	29
LCR 3/8	1.00	0.75		47	44	41	39	38	33
LCR 3/9	1.00	0.75		52	50	46	44	41	36
LCR 3/10	1.00	0.75		58	55	51	49	46	40
LCR 3/11	1.50	1.10		64	60	56	53	51	45
LCR 3/12	1.50	1.10		69	66	61	58	55	48
LCR 3/13	1.50	1.10		75	71	66	63	60	53
LCR 3/15	1.50	1.10		86	80	75	71	68	60
LCR 3/17	2.00	1.50		100	94	87	83	79	70
LCR 3/19	2.00	1.50		110	104	97	91	88	77
LCR 3/21	3.00	2.20		123	116	108	102	98	86
LCR 3/23	3.00	2.20		135	127	118	112	107	95
LCR 3/25	3.00	2.20		146	138	128	121	116	102
LCR 3/27	3.00	2.20		157	148	138	130	124	110
LCR 3/29	3.00	2.20		169	159	148	140	134	118
LCR 3/31	4.00	3.00		182	172	159	151	144	127
LCR 3/33	4.00	3.00		193	182	170	161	154	136
LCR 3/36	4.00	3.00		211	199	185	176	168	148

Dimensions & Weights of LCR Pump

Pump type	Dimensions [mm]						Net weight [kg]		Gross weight [kg]		Gross volume [m ³]
	Oval flange		DIN flange		D1	D2	Oval flange	DIN flange	Oval flange	DIN flange	
	B1	B1+B2	B1	B1+B2							
LCR 3/2	236	449	261	474	143	106	18.0	23.0	28.0	33.0	0.1030
LCR 3/3	254	467	279	492	143	106	18.0	23.0	28.0	33.0	0.1030
LCR 3/4	272	485	297	510	143	106	19.0	23.0	29.0	33.0	0.1030
LCR 3/5	290	503	315	528	143	106	19.0	24.0	29.0	34.0	0.1030
LCR 3/6	308	521	333	546	143	106	20.0	25.0	30.0	35.0	0.1030
LCR 3/7	326	539	351	564	143	106	21.0	25.0	31.0	35.0	0.1030
LCR 3/8	350	614	375	639	160	113	23.0	27.0	37.0	41.0	0.1428
LCR 3/9	368	632	393	657	160	113	23.0	28.0	37.0	42.0	0.1428
LCR 3/10	386	650	411	675	160	113	24.0	28.0	38.0	42.0	0.1428
LCR 3/11	404	668	429	693	160	113	26.0	31.0	40.0	45.0	0.1428
LCR 3/12	422	686	447	711	160	113	26.0	31.0	40.0	45.0	0.1428
LCR 3/13	440	704	465	729	160	113	27.0	31.0	41.0	45.0	0.1428
LCR 3/15	476	740	501	765	160	113	28.0	32.0	42.0	46.0	0.1428
LCR 3/17	528	806	553	831	165	130	36.0	40.0	50.0	54.0	0.1428
LCR 3/19	564	842	589	867	165	130	37.0	41.0	55.0	59.0	0.1825
LCR 3/21	600	878	625	903	165	130	38.0	42.0	56.0	60.0	0.1825
LCR 3/23	636	914	661	939	165	130	39.0	43.0	57.0	61.0	0.1825
LCR 3/25	-	-	697	975	165	130	-	44.0	-	62.0	0.1825
LCR 3/27	-	-	733	1011	165	130	-	45.0	-	63.0	0.1825
LCR 3/29	-	-	769	1047	165	130	-	46.0	-	64.0	0.1825
LCR 3/31	-	-	809	1113	194	140	-	51.0	-	80.0	0.2996
LCR 3/33	-	-	845	1149	194	140	-	51.0	-	80.0	0.2996
LCR 3/36	-	-	899	1203	194	140	-	53.0	-	82.0	0.2996

Performance Curves

Vertical multistage centrifugal pumps

LCR 3

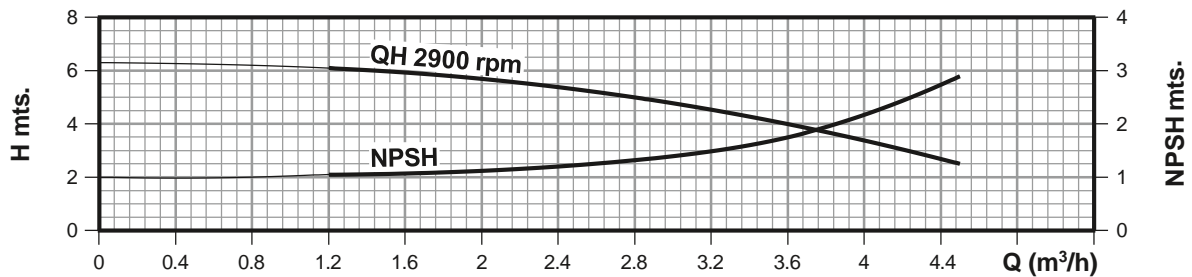
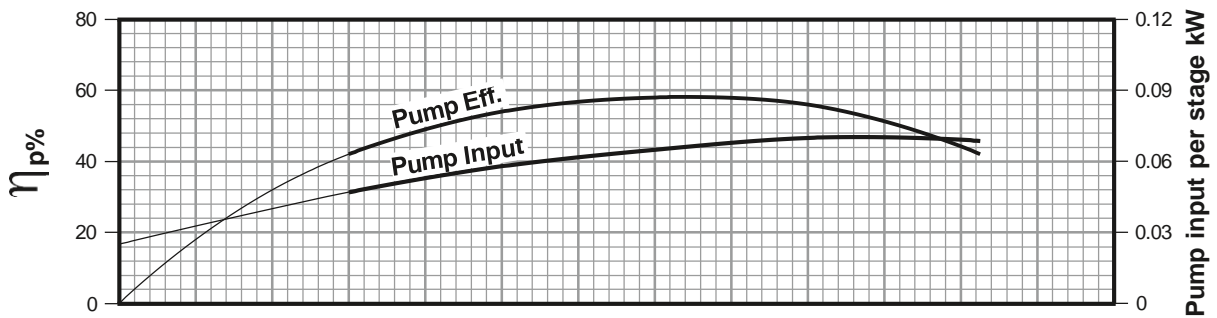
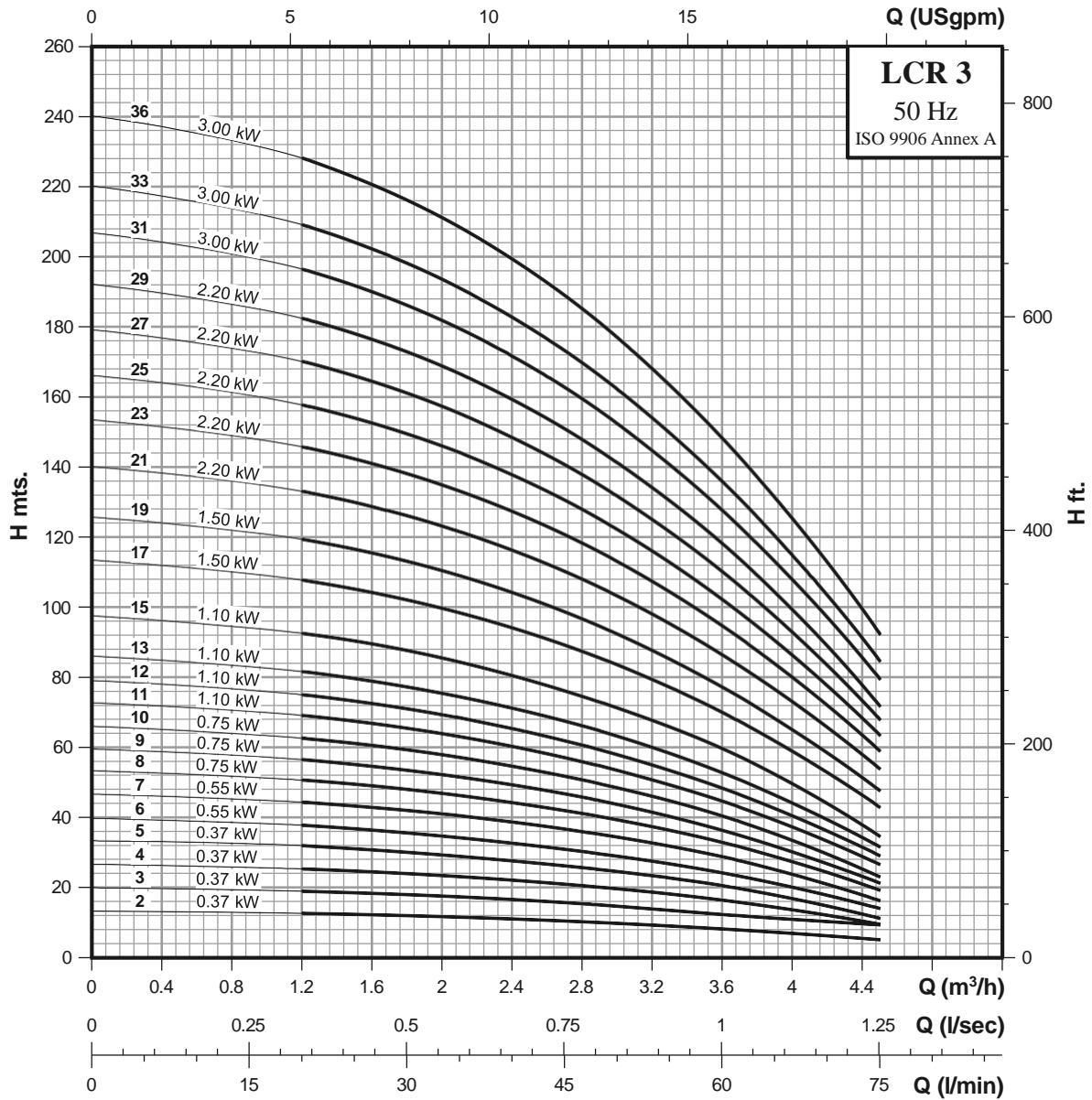

Technical Data

Vertical multistage centrifugal pumps

LCRI, LCRN 3

Performance Chart

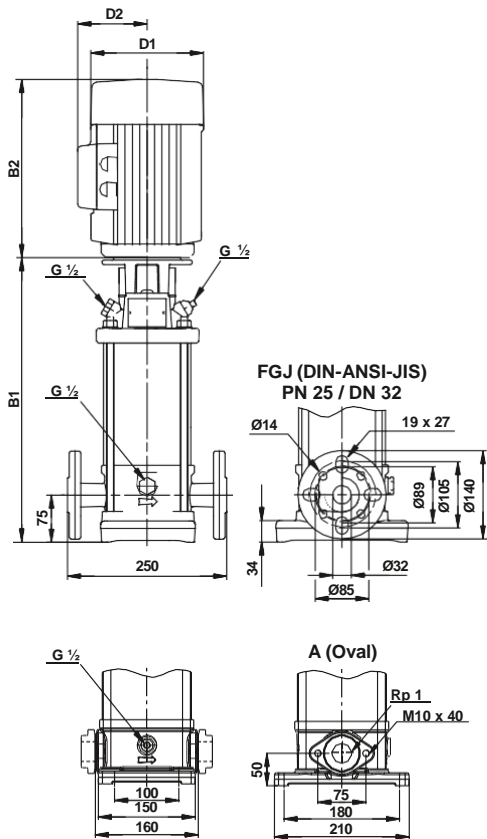

Pump Type	H.P.	kW	Q	n = 2900 rpm						
				I/min	33.3	40.0	46.7	50.0	53.3	60.0
				m ³ /h	2.0	2.4	2.8	3.0	3.2	3.6
LCRI, LCRN 3/2	0.50	0.37	H mts.	12	11	10	10	9	8	
LCRI, LCRN 3/3	0.50	0.37		18	17	15	15	14	12	
LCRI, LCRN 3/4	0.50	0.37		23	22	21	19	18	16	
LCRI, LCRN 3/5	0.50	0.37		29	28	26	24	23	21	
LCRI, LCRN 3/6	0.75	0.55		35	33	30	29	27	24	
LCRI, LCRN 3/7	0.75	0.55		41	38	36	34	33	29	
LCRI, LCRN 3/8	1.00	0.75		47	44	41	39	38	33	
LCRI, LCRN 3/9	1.00	0.75		52	50	46	44	41	36	
LCRI, LCRN 3/10	1.00	0.75		58	55	51	49	46	40	
LCRI, LCRN 3/11	1.50	1.10		64	60	56	53	51	45	
LCRI, LCRN 3/12	1.50	1.10		69	66	61	58	55	48	
LCRI, LCRN 3/13	1.50	1.10		75	71	66	63	60	53	
LCRI, LCRN 3/15	1.50	1.10		86	80	75	71	68	60	
LCRI, LCRN 3/17	2.00	1.50		100	94	87	83	79	70	
LCRI, LCRN 3/19	2.00	1.50		110	104	97	91	88	77	
LCRI, LCRN 3/21	3.00	2.20		123	116	108	102	98	86	
LCRI, LCRN 3/23	3.00	2.20		135	127	118	112	107	95	
LCRI, LCRN 3/25	3.00	2.20		146	138	128	121	116	102	
LCRI, LCRN 3/27	3.00	2.20		157	148	138	130	124	110	
LCRI, LCRN 3/29	3.00	2.20		169	159	148	140	134	118	
LCRI, LCRN 3/31	4.00	3.00		182	172	159	151	144	127	
LCRI, LCRN 3/33	4.00	3.00		193	182	170	161	154	136	
LCRI, LCRN 3/36	4.00	3.00		211	199	185	176	168	148	

Dimensions & Weights of LCRI, LCRN Pump

Pump type	Dimensions [mm]						Net weight [kg]	Gross weight [kg]	Gross volume [m ³]
	Oval flange		DIN flange		D1	D2			
	B1	B1+B2	B1	B1+B2					
LCRI, LCRN 3/2	239	452	264	477	143	106	19.0	29.0	0.1030
LCRI, LCRN 3/3	257	470	282	495	143	106	19.0	29.0	0.1030
LCRI, LCRN 3/4	275	488	300	513	143	106	19.0	29.0	0.1030
LCRI, LCRN 3/5	293	506	318	531	143	106	20.0	30.0	0.1030
LCRI, LCRN 3/6	311	524	336	549	143	106	21.0	31.0	0.1030
LCRI, LCRN 3/7	329	542	354	567	143	106	21.0	31.0	0.1030
LCRI, LCRN 3/8	353	617	378	642	160	113	24.0	38.0	0.1428
LCRI, LCRN 3/9	371	635	396	660	160	113	24.0	38.0	0.1428
LCRI, LCRN 3/10	389	653	414	678	160	113	25.0	39.0	0.1428
LCRI, LCRN 3/11	407	671	432	696	160	113	27.0	41.0	0.1428
LCRI, LCRN 3/12	425	689	450	714	160	113	28.0	42.0	0.1428
LCRI, LCRN 3/13	443	707	468	732	160	113	28.0	42.0	0.1428
LCRI, LCRN 3/15	479	743	504	768	160	113	29.0	43.0	0.1428
LCRI, LCRN 3/17	531	809	556	834	165	130	36.0	50.0	0.1428
LCRI, LCRN 3/19	567	845	592	870	165	130	37.0	55.0	0.1825
LCRI, LCRN 3/21	603	881	628	906	165	130	38.0	56.0	0.1825
LCRI, LCRN 3/23	639	917	664	942	165	130	39.0	57.0	0.1825
LCRI, LCRN 3/25	675	953	700	978	165	130	40.0	58.0	0.1825
LCRI, LCRN 3/27	711	989	736	1014	165	130	41.0	59.0	0.1825
LCRI, LCRN 3/29	747	1025	772	1050	165	130	42.0	60.0	0.1825
LCRI, LCRN 3/31	787	1091	812	1116	194	140	47.0	76.0	0.2996
LCRI, LCRN 3/33	823	1127	848	1152	194	140	47.0	76.0	0.2996
LCRI, LCRN 3/36	877	1181	902	1206	194	140	49.0	78.0	0.2996

Performance Curves

Vertical multistage centrifugal pumps

LCRI, LCRN 3

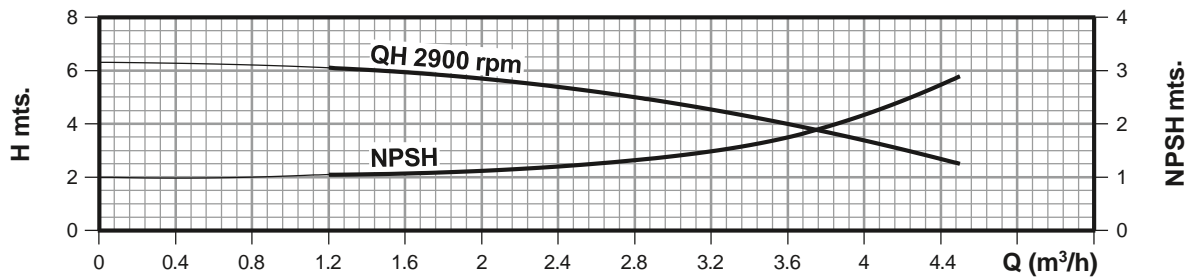
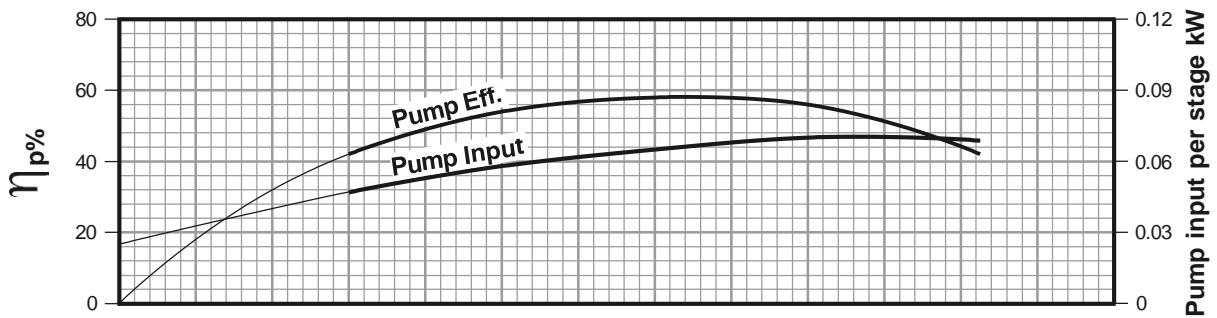
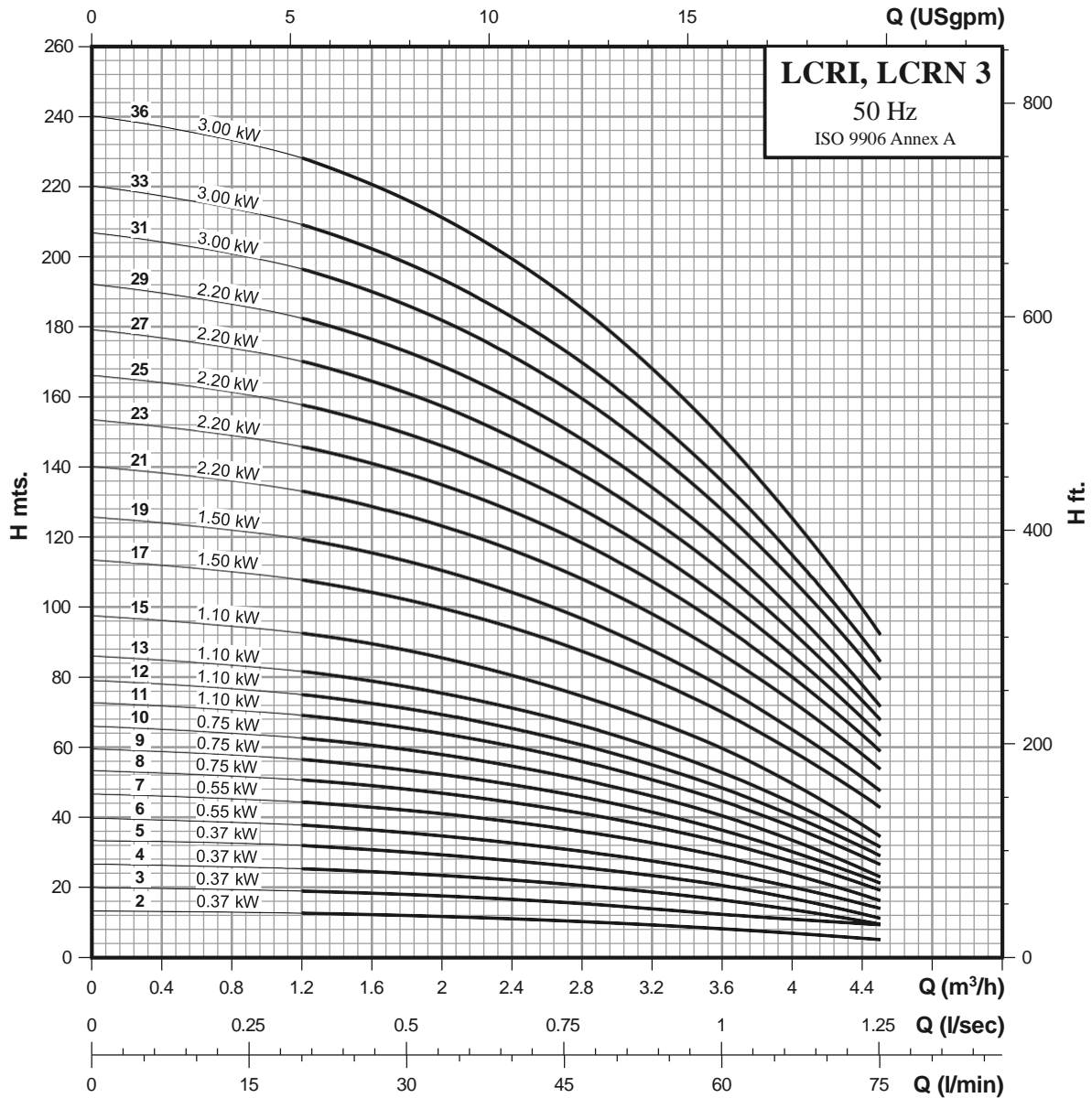

Technical Data

Vertical multistage centrifugal pumps

LCR 4

Performance Chart

Pump Type	H.P.	kW	Q	n = 2900 rpm						
				l/min	31.7	56.7	75.0	95.0	113.3	131.7
				m ³ /h	1.9	3.4	4.5	5.7	6.8	7.9
			H mts.	18	16	14	12	9	5	
LCR 4/2	0.50	0.37		28	25	23	19	15	10	
LCR 4/3	0.75	0.55		38	34	30	26	21	14	
LCR 4/4	1.00	0.75		48	44	39	34	26	17	
LCR 4/5	1.50	1.10		56	50	45	39	30	21	
LCR 4/6	1.50	1.10		66	60	54	47	37	26	
LCR 4/7	2.00	1.50		75	67	61	52	42	28	
LCR 4/8	2.00	1.50		95	87	78	67	54	37	
LCR 4/10	3.00	2.20		111	101	91	79	63	43	
LCR 4/12	3.00	2.20		132	121	110	95	76	52	
LCR 4/14	4.00	3.00		151	137	123	106	85	57	
LCR 4/16	4.00	3.00		180	165	149	129	104	72	
LCR 4/19	5.50	4.00	207	188	171	148	118	81		
LCR 4/22	5.50	4.00								

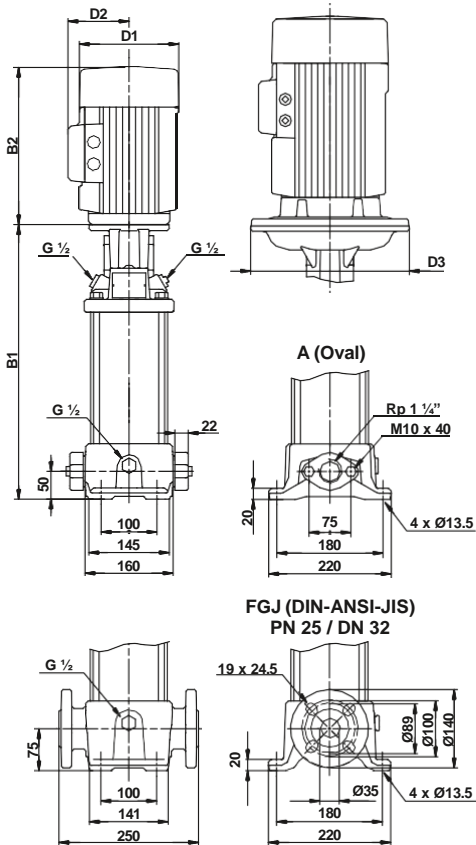

FGJ (DIN-ANSI-JIS)
PN 25 / DN 32

Dimensions & Weights of LCR Pump

Pump type	Dimensions [mm]						Net weight [kg]		Gross weight [kg]		Gross volume [m ³]
	Oval flange		DIN flange		D1	D2	Oval flange	DIN flange	Oval flange	DIN flange	
	B1	B1+B2	B1	B1+B2							
LCR 4/2	254	467	279	492	143	106	18.0	23.0	28.0	33.0	0.1030
LCR 4/3	281	494	306	519	143	106	20.0	24.0	30.0	34.0	0.1030
LCR 4/4	308	572	333	597	160	113	22.0	27.0	36.0	41.0	0.1428
LCR 4/5	341	605	366	630	160	113	25.0	29.0	39.0	43.0	0.1428
LCR 4/6	368	632	393	657	160	113	25.0	30.0	39.0	44.0	0.1428
LCR 4/7	395	673	420	698	165	130	34.0	37.0	48.0	51.0	0.1428
LCR 4/8	422	700	447	725	165	130	34.0	38.0	48.0	52.0	0.1428
LCR 4/10	492	770	517	795	165	130	36.0	40.0	50.0	54.0	0.1428
LCR 4/12	546	824	571	849	165	130	36.0	41.0	54.0	59.0	0.1825
LCR 4/14	600	904	625	929	194	140	42.0	44.0	62.0	64.0	0.2650
LCR 4/16	654	958	679	983	194	140	43.0	46.0	66.0	69.0	0.2650
LCR 4/19	739	1089	764	1114	220	150	54.0	60.0	83.0	89.0	0.2996
LCR 4/22	820	1170	845	1195	220	150	56.0	62.0	85.0	91.0	0.2996

Performance Curves

Vertical multistage centrifugal pumps

LCR 4

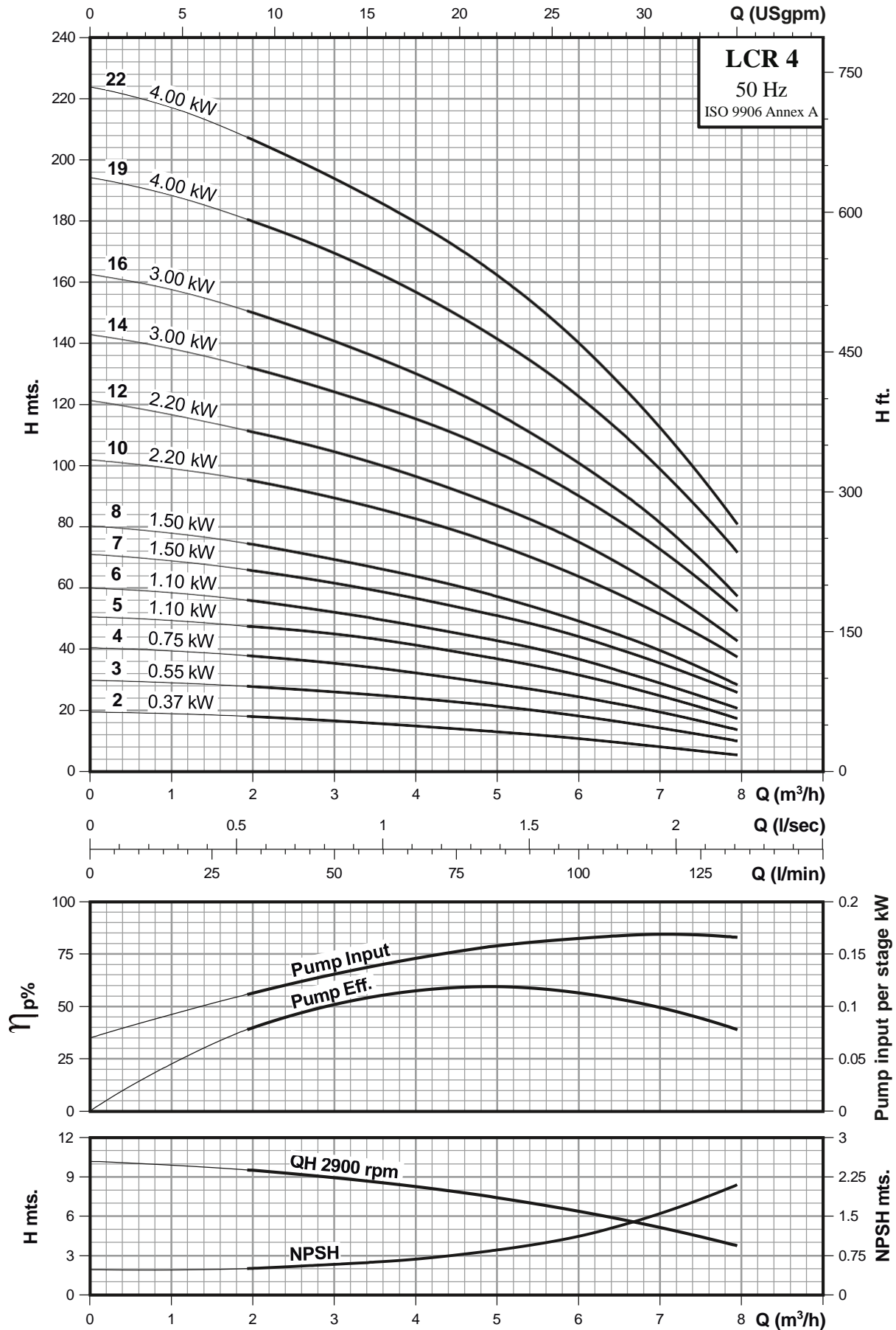

Technical Data

Vertical multistage centrifugal pumps

LCRI, LCRN 4

Performance Chart

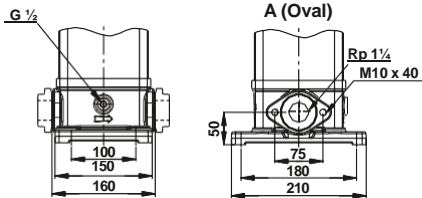
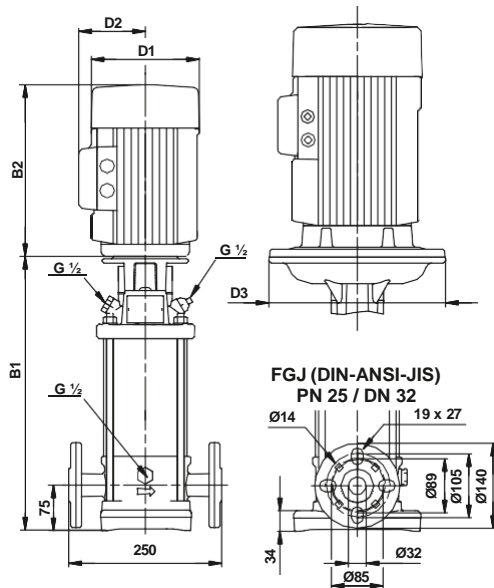

Pump Type	H.P.	kW	Q l/min m ³ /h	n = 2900 rpm					
				31.7	56.7	75.0	95.0	113.3	131.7
				1.9	3.4	4.5	5.7	6.8	7.9
LCRI, LCRN 4/2	0.50	0.37	H mts.	18	16	14	12	9	5
LCRI, LCRN 4/3	0.75	0.55		28	25	23	19	15	10
LCRI, LCRN 4/4	1.00	0.75		38	34	30	26	21	14
LCRI, LCRN 4/5	1.50	1.10		48	44	39	34	26	17
LCRI, LCRN 4/6	1.50	1.10		56	50	45	39	30	21
LCRI, LCRN 4/7	2.00	1.50		66	60	54	47	37	26
LCRI, LCRN 4/8	2.00	1.50		75	67	61	52	42	28
LCRI, LCRN 4/10	3.00	2.20		95	87	78	67	54	37
LCRI, LCRN 4/12	3.00	2.20		111	101	91	79	63	43
LCRI, LCRN 4/14	4.00	3.00		132	121	110	95	76	52
LCRI, LCRN 4/16	4.00	3.00		151	137	123	106	85	57
LCRI, LCRN 4/19	5.50	4.00		180	165	149	129	104	72
LCRI, LCRN 4/22	5.50	4.00		207	188	171	148	118	81

Dimensions & Weights of LCRI, LCRN Pump

Pump type	Dimensions [mm]						Net weight [kg]	Gross weight [kg]	Gross volume [m ³]
	Oval flange		DIN flange		D1	D2			
	B1	B1+B2	B1	B1+B2					
LCRI, LCRN 4/2	257	470	282	495	143	106	21.0	31.0	0.1030
LCRI, LCRN 4/3	284	497	309	522	143	106	22.0	32.0	0.1030
LCRI, LCRN 4/4	311	575	336	600	160	113	25.0	39.0	0.1428
LCRI, LCRN 4/5	344	608	369	633	160	113	27.0	41.0	0.1428
LCRI, LCRN 4/6	371	635	396	660	160	113	28.0	42.0	0.1428
LCRI, LCRN 4/7	398	676	423	701	165	130	35.0	49.0	0.1428
LCRI, LCRN 4/8	425	703	450	728	165	130	36.0	50.0	0.1428
LCRI, LCRN 4/10	495	773	520	798	165	130	37.0	55.0	0.1428
LCRI, LCRN 4/12	549	827	574	852	165	130	38.0	56.0	0.1825
LCRI, LCRN 4/14	603	907	628	932	194	140	44.0	64.0	0.2650
LCRI, LCRN 4/16	657	961	682	986	194	140	45.0	68.0	0.2650
LCRI, LCRN 4/19	742	1092	767	1117	220	150	57.0	86.0	0.2996
LCRI, LCRN 4/22	823	1173	848	1198	220	150	59.0	88.0	0.2996

Performance Curves

Vertical multistage centrifugal pumps

LCRI, LCRN 4

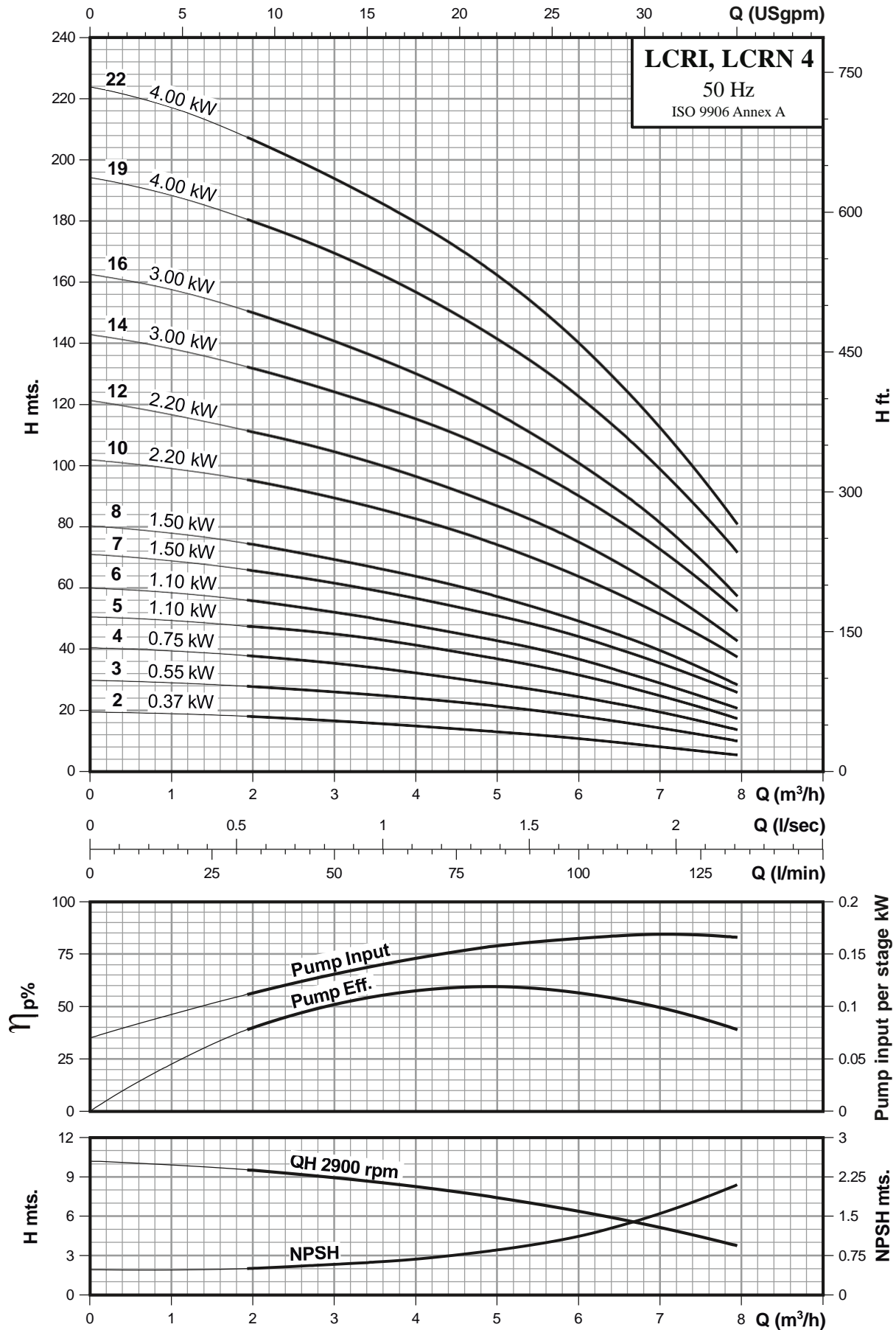

Technical Data

Vertical multistage centrifugal pumps

LCR 5

Performance Chart

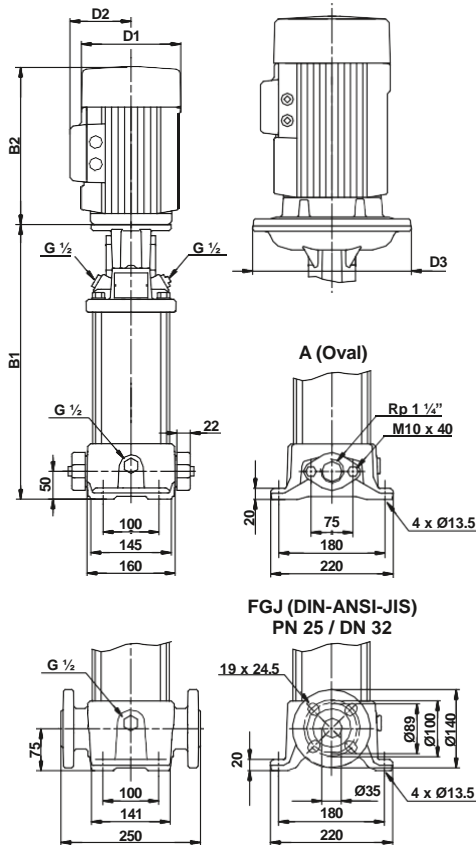

Pump Type	H.P.	kW	Q l/min m ³ /h	n = 2900 rpm				
				41.7	66.7	83.3	100.0	116.7
				2.5	4.0	5.0	6.0	7.0
LCR 5/2	0.50	0.37	H mts.	13	12	11	10	8
LCR 5/3	0.75	0.55		19	18	16	15	12
LCR 5/4	0.75	0.55		25	24	22	20	16
LCR 5/5	1.00	0.75		32	29	28	25	20
LCR 5/6	1.50	1.10		38	35	33	30	25
LCR 5/7	1.50	1.10		45	42	39	35	29
LCR 5/8	1.50	1.10		52	48	44	40	34
LCR 5/9	2.00	1.50		59	54	50	46	39
LCR 5/10	2.00	1.50		65	60	56	51	44
LCR 5/11	3.00	2.20		72	67	62	56	48
LCR 5/12	3.00	2.20		78	72	67	61	52
LCR 5/13	3.00	2.20		85	78	73	66	57
LCR 5/14	3.00	2.20		92	85	79	71	62
LCR 5/15	3.00	2.20		98	91	84	76	66
LCR 5/16	3.00	2.20		104	97	90	81	70
LCR 5/18	4.00	3.00		118	110	102	93	80
LCR 5/20	4.00	3.00		132	122	113	103	89
LCR 5/22	5.50	4.00		145	134	124	113	99
LCR 5/24	5.50	4.00		157	145	135	122	106
LCR 5/26	5.50	4.00		171	159	146	132	114
LCR 5/29	5.50	4.00		191	177	164	149	130
LCR 5/32	7.50	5.50		211	195	181	165	144
LCR 5/36	7.50	5.50		235	218	202	185	162

Dimensions & Weights of LCR Pump

Pump type	Dimensions [mm]							Net weight [kg]		Gross weight [kg]		Gross volume [m ³]
	Oval flange		DIN flange		D1	D2	D3	Oval flange	DIN flange	Oval flange	DIN flange	
	B1	B1+B2	B1	B1+B2								
LCR 5/2	254	467	279	492	143	106	-	18.0	23.0	28.0	33.0	0.1030
LCR 5/3	281	494	306	519	143	106	-	20.0	24.0	30.0	34.0	0.1030
LCR 5/4	308	521	333	546	143	106	-	20.0	25.0	30.0	35.0	0.1030
LCR 5/5	341	605	366	630	160	113	-	22.0	27.0	36.0	41.0	0.1428
LCR 5/6	368	632	393	657	160	113	-	25.0	30.0	39.0	44.0	0.1428
LCR 5/7	395	659	420	684	160	113	-	26.0	30.0	40.0	44.0	0.1428
LCR 5/8	422	686	447	711	160	113	-	26.0	31.0	40.0	45.0	0.1428
LCR 5/9	465	743	490	768	165	130	-	34.0	38.0	48.0	52.0	0.1428
LCR 5/10	492	770	517	795	165	130	-	34.0	39.0	48.0	53.0	0.1428
LCR 5/11	519	797	544	822	165	130	-	36.0	40.0	50.0	54.0	0.1428
LCR 5/12	546	824	571	849	165	130	-	36.0	41.0	54.0	59.0	0.1825
LCR 5/13	573	851	598	876	165	130	-	37.0	41.0	55.0	59.0	0.1825
LCR 5/14	600	878	625	903	165	130	-	37.0	42.0	55.0	60.0	0.1825
LCR 5/15	627	905	652	930	165	130	-	38.0	43.0	56.0	61.0	0.1825
LCR 5/16	654	932	679	957	165	130	-	38.0	43.0	56.0	61.0	0.1825
LCR 5/18	712	1016	737	1041	194	140	-	44.0	48.0	70.0	74.0	0.2650
LCR 5/20	766	1070	791	1095	194	140	-	45.0	50.0	74.0	79.0	0.2996
LCR 5/22	820	1170	845	1195	220	150	-	56.0	62.0	85.0	91.0	0.2996
LCR 5/24	-	-	899	1249	220	150	-	-	63.0	-	97.0	0.3458
LCR 5/26	-	-	953	1303	220	150	-	-	64.0	-	98.0	0.3458
LCR 5/29	-	-	1034	1384	220	150	-	-	66.0	-	100.0	0.3458
LCR 5/32	-	-	1145	1555	262	177	300	-	82.0	-	122.0	0.4035
LCR 5/36	-	-	1253	1663	262	177	300	-	84.0	-	124.0	0.4035

Performance Curves

Vertical multistage centrifugal pumps

LCR 5

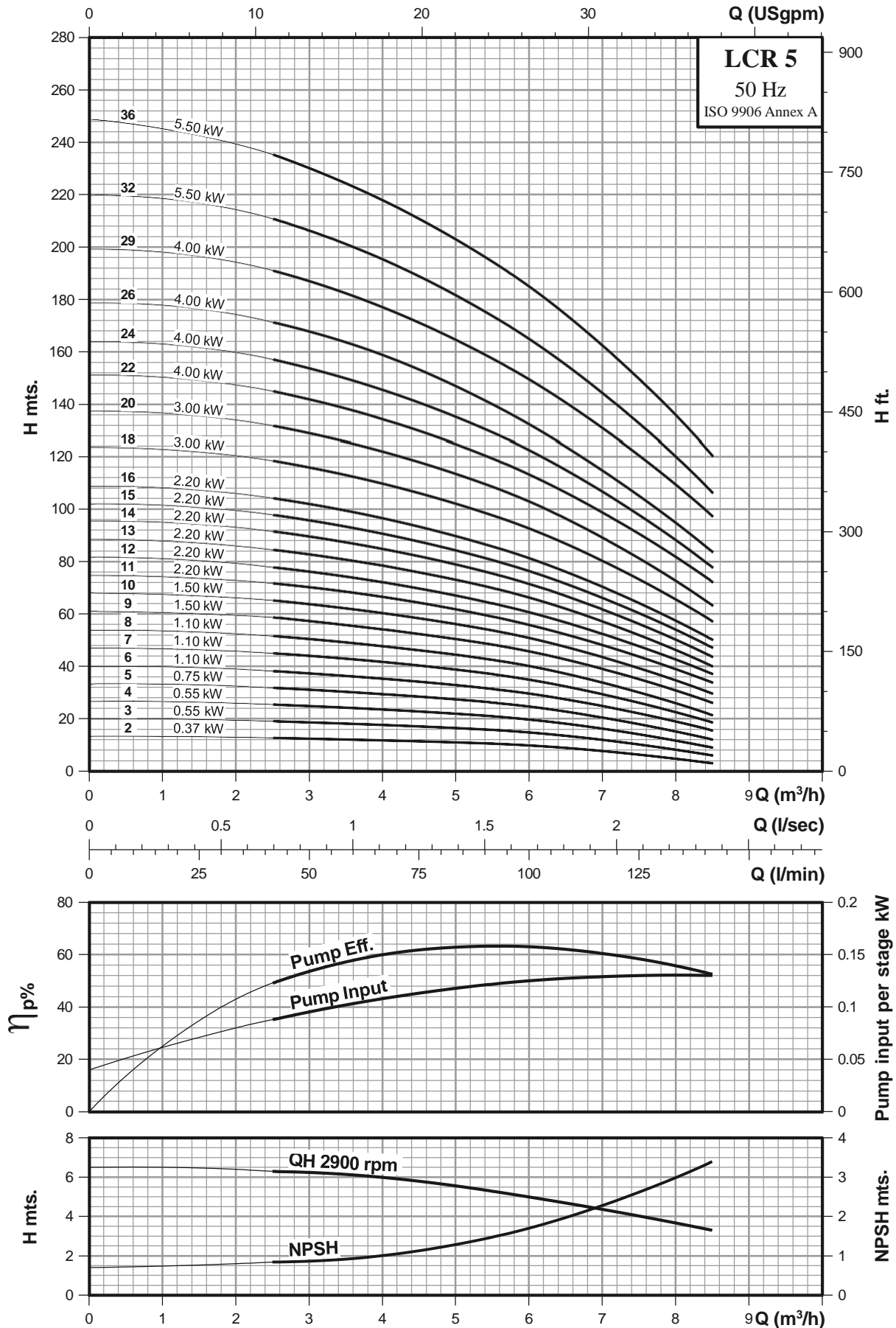

Technical Data

Vertical multistage centrifugal pumps

LCRI, LCRN 5

Performance Chart

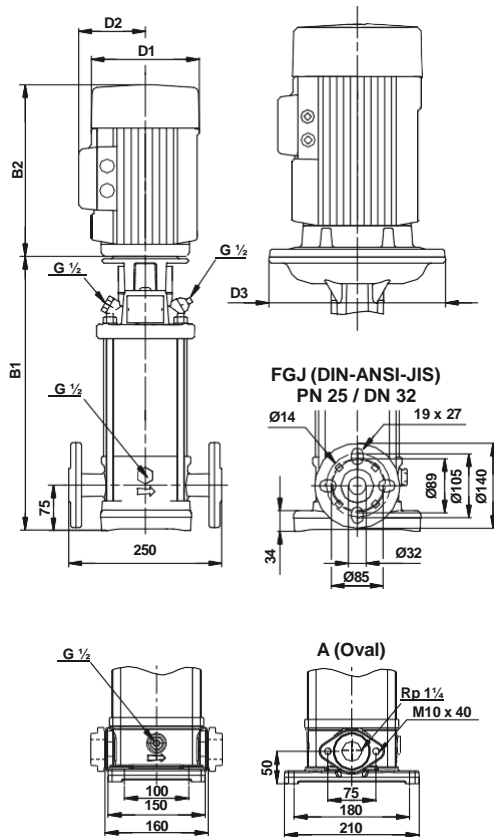

Pump Type	H.P.	kW	Q l/min m ³ /h	n = 2900 rpm				
				41.7	66.7	83.3	100.0	116.7
				2.5	4.0	5.0	6.0	7.0
LCRI, LCRN 5/2	0.50	0.37	H mts.	13	12	11	10	8
LCRI, LCRN 5/3	0.75	0.55		19	18	16	15	12
LCRI, LCRN 5/4	0.75	0.55		25	24	22	20	16
LCRI, LCRN 5/5	1.00	0.75		32	29	28	25	20
LCRI, LCRN 5/6	1.50	1.10		38	35	33	30	25
LCRI, LCRN 5/7	1.50	1.10		45	42	39	35	29
LCRI, LCRN 5/8	1.50	1.10		52	48	44	40	34
LCRI, LCRN 5/9	2.00	1.50		59	54	50	46	39
LCRI, LCRN 5/10	2.00	1.50		65	60	56	51	44
LCRI, LCRN 5/11	3.00	2.20		72	67	62	56	48
LCRI, LCRN 5/12	3.00	2.20		78	72	67	61	52
LCRI, LCRN 5/13	3.00	2.20		85	78	73	66	57
LCRI, LCRN 5/14	3.00	2.20		92	85	79	71	62
LCRI, LCRN 5/15	3.00	2.20		98	91	84	76	66
LCRI, LCRN 5/16	3.00	2.20		104	97	90	81	70
LCRI, LCRN 5/18	4.00	3.00		118	110	102	93	80
LCRI, LCRN 5/20	4.00	3.00		132	122	113	103	89
LCRI, LCRN 5/22	5.50	4.00		145	134	124	113	99
LCRI, LCRN 5/24	5.50	4.00		157	145	135	122	106
LCRI, LCRN 5/26	5.50	4.00		171	159	146	132	114
LCRI, LCRN 5/29	5.50	4.00		191	177	164	149	130
LCRI, LCRN 5/32	7.50	5.50		211	195	181	165	144
LCRI, LCRN 5/36	7.50	5.50		235	218	202	185	162

Dimensions & Weights of LCRI, LCRN Pump

Pump type	Dimensions [mm]							Net weight [kg]	Gross weight [kg]	Gross volume [m ³]
	Oval flange		DIN flange		D1	D2	D3			
	B1	B1+B2	B1	B1+B2						
LCRI, LCRN 5/2	257	470	282	495	143	106	-	21.0	31.0	0.1030
LCRI, LCRN 5/3	284	497	309	522	143	106	-	22.0	32.0	0.1030
LCRI, LCRN 5/4	311	524	336	549	143	106	-	22.0	32.0	0.1030
LCRI, LCRN 5/5	344	608	369	633	160	113	-	25.0	39.0	0.1428
LCRI, LCRN 5/6	371	635	396	660	160	113	-	28.0	42.0	0.1428
LCRI, LCRN 5/7	398	662	423	687	160	113	-	28.0	42.0	0.1428
LCRI, LCRN 5/8	425	689	450	714	160	113	-	29.0	43.0	0.1428
LCRI, LCRN 5/9	468	746	493	771	165	130	-	36.0	50.0	0.1428
LCRI, LCRN 5/10	495	773	520	798	165	130	-	37.0	51.0	0.1428
LCRI, LCRN 5/11	522	800	547	825	165	130	-	38.0	52.0	0.1428
LCRI, LCRN 5/12	549	827	574	852	165	130	-	38.0	56.0	0.1825
LCRI, LCRN 5/13	576	854	601	879	165	130	-	39.0	57.0	0.1825
LCRI, LCRN 5/14	603	881	628	906	165	130	-	40.0	58.0	0.1825
LCRI, LCRN 5/15	630	908	655	933	165	130	-	40.0	58.0	0.1825
LCRI, LCRN 5/16	657	935	682	960	165	130	-	41.0	59.0	0.1825
LCRI, LCRN 5/18	715	1019	740	1044	194	140	-	46.0	72.0	0.2650
LCRI, LCRN 5/20	769	1073	794	1098	194	140	-	47.0	76.0	0.2996
LCRI, LCRN 5/22	823	1173	848	1198	220	150	-	59.0	88.0	0.2996
LCRI, LCRN 5/24	877	1227	902	1252	220	150	-	61.0	95.0	0.3458
LCRI, LCRN 5/26	931	1281	956	1306	220	150	-	62.0	96.0	0.3458
LCRI, LCRN 5/29	1012	1362	1037	1387	220	150	-	64.0	98.0	0.3458
LCRI, LCRN 5/32	1123	1533	1148	1558	262	177	300	79.0	119.0	0.4035
LCRI, LCRN 5/36	1231	1641	1256	1666	262	177	300	81.0	121.0	0.4035

Performance Curves

Vertical multistage centrifugal pumps

LCRI, LCRN 5

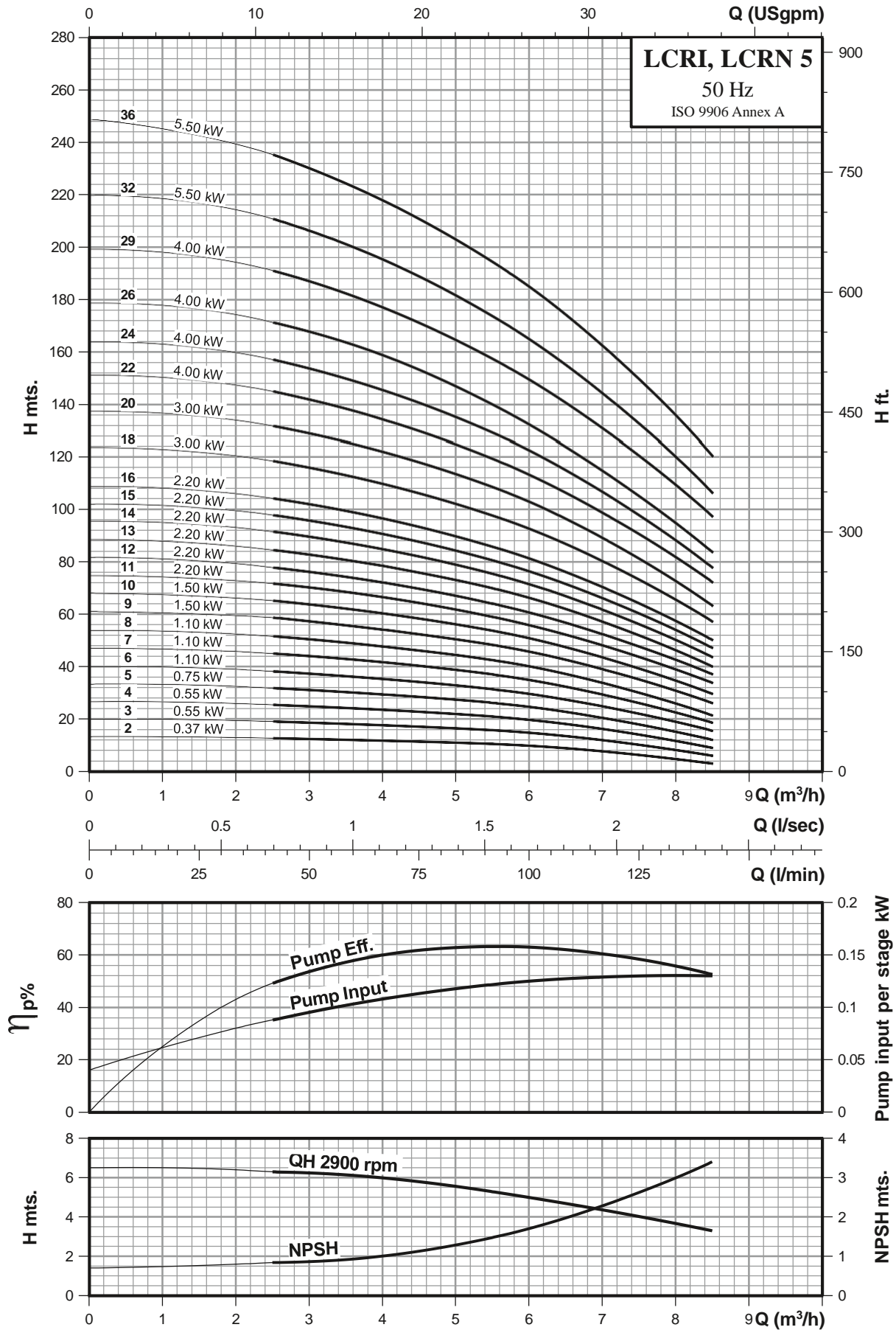

Technical Data

Vertical multistage centrifugal pumps

LCR 10

Performance Chart

Pump Type	H.P.	kW	Q l/min m ³ /h	n = 2900 rpm					
				116.7	133.3	150.0	166.7	183.3	200.0
				7.0	8.0	9.0	10.0	11.0	12.0
LCR 10/1	0.50	0.37	H mts.	10	9	8	8	7	6
LCR 10/2	1.00	0.75		19	18	17	16	14	12
LCR 10/3	1.50	1.10		29	28	26	24	22	19
LCR 10/4	2.00	1.50		38	37	34	32	29	26
LCR 10/5	3.00	2.20		48	47	44	41	38	34
LCR 10/6	3.00	2.20		58	56	53	49	45	40
LCR 10/7	4.00	3.00		68	65	62	57	52	47
LCR 10/8	4.00	3.00		78	75	70	65	60	53
LCR 10/9	4.00	3.00		88	84	79	73	66	59
LCR 10/10	5.50	4.00		97	93	88	82	75	67
LCR 10/12	5.50	4.00		116	111	105	98	89	80
LCR 10/14	7.50	5.50		136	130	123	115	105	94
LCR 10/16	7.50	5.50		154	148	140	130	119	106
LCR 10/18	10.0	7.50		174	168	158	147	135	122
LCR 10/20	10.0	7.50		194	186	176	164	150	135
LCR 10/22	10.0	7.50		213	205	193	180	165	148

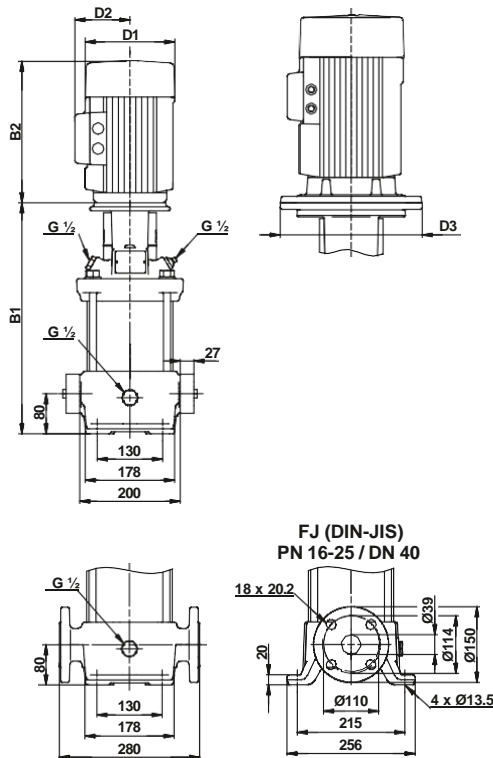

Dimensions & Weights of LCR Pump

Pump type	Dimensions [mm]					Net weight [kg]	Gross weight [kg]	Gross volume [m ³]
	DIN flange		D1	D2	D3			
	B1	B1+B2						
LCR 10/1	343	556	143	106	-	34.0	48.0	0.1428
LCR 10/2	347	611	160	113	-	36.0	50.0	0.1428
LCR 10/3	377	641	160	113	-	39.0	53.0	0.1428
LCR 10/4	423	701	165	130	-	47.0	61.0	0.1428
LCR 10/5	453	731	165	130	-	49.0	63.0	0.1428
LCR 10/6	483	761	165	130	-	50.0	64.0	0.1428
LCR 10/7	518	822	194	140	-	55.0	81.0	0.2650
LCR 10/8	548	852	194	140	-	56.0	82.0	0.2650
LCR 10/9	578	882	194	140	-	57.0	83.0	0.2650
LCR 10/10	608	958	220	150	-	69.0	95.0	0.2650
LCR 10/12	668	1018	220	150	-	71.0	97.0	0.2650
LCR 10/14	760	1170	262	177	300	94.0	123.0	0.2996
LCR 10/16	820	1230	262	177	300	96.0	130.0	0.3458
LCR 10/18	880	1290	262	177	300	101.0	135.0	0.3458
LCR 10/20	940	1350	262	177	300	103.0	137.0	0.3458
LCR 10/22	1000	1410	262	177	300	105.0	139.0	0.3458

Performance Curves

Vertical multistage centrifugal pumps

LCR 10

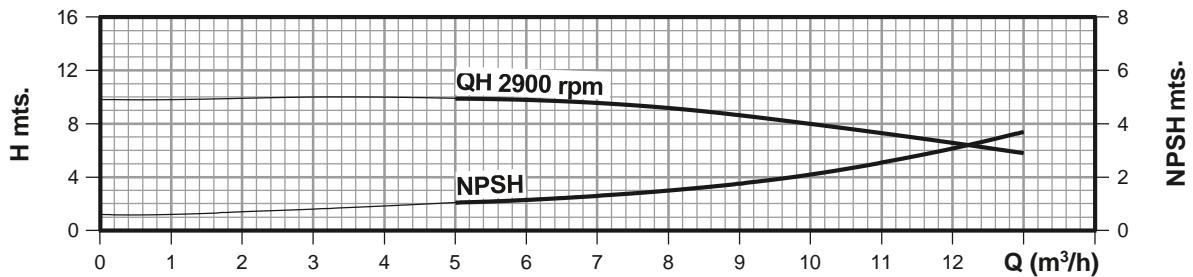
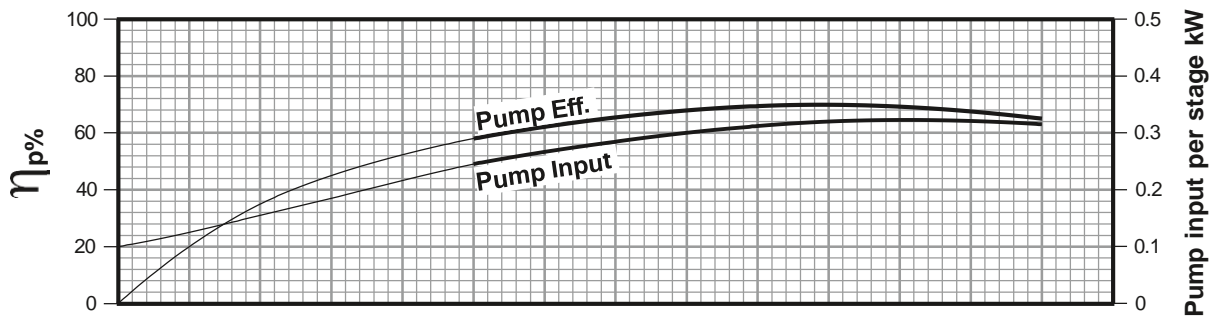
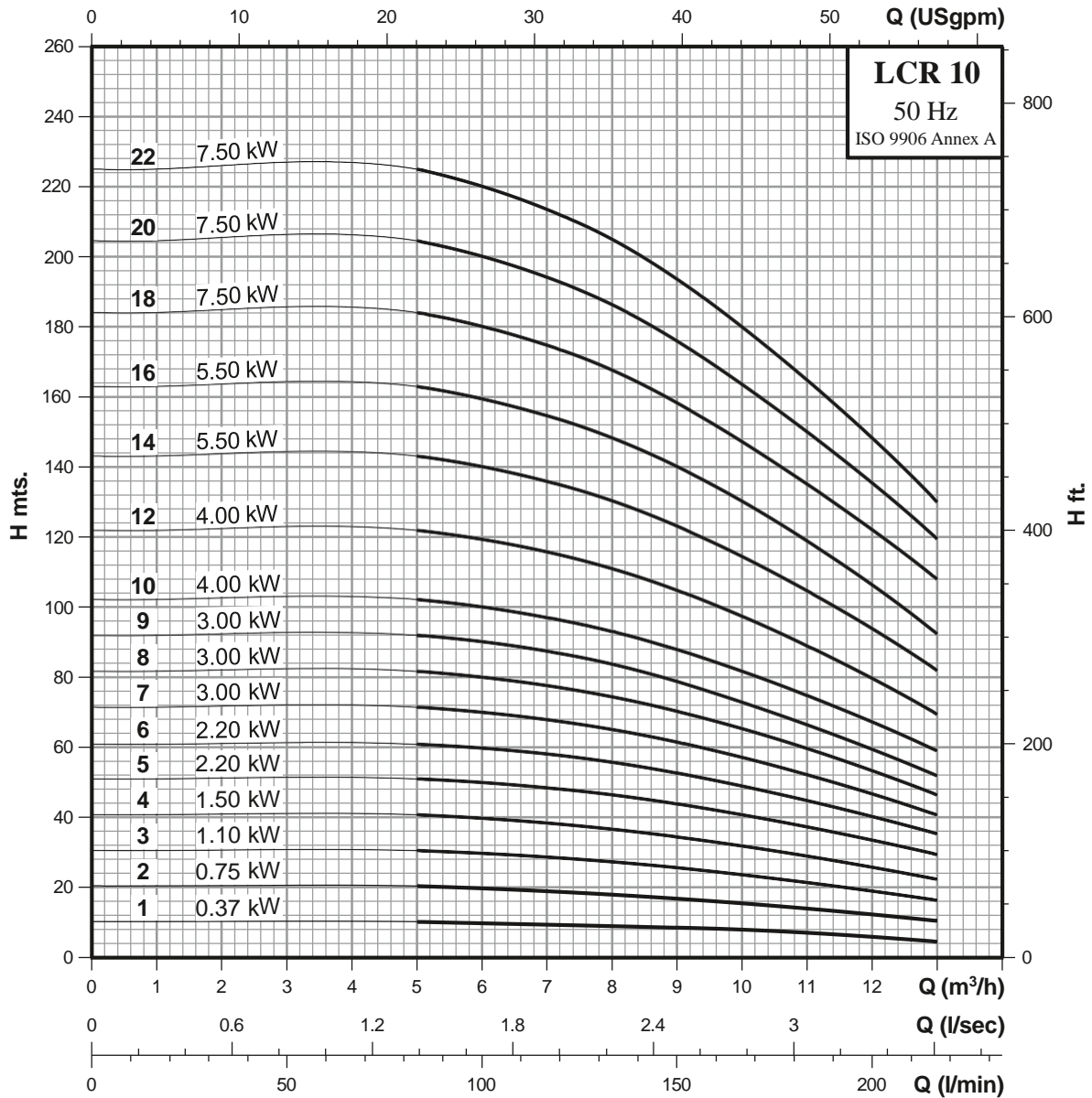

Technical Data

Vertical multistage centrifugal pumps

LCRI, LCRN 10

Performance Chart

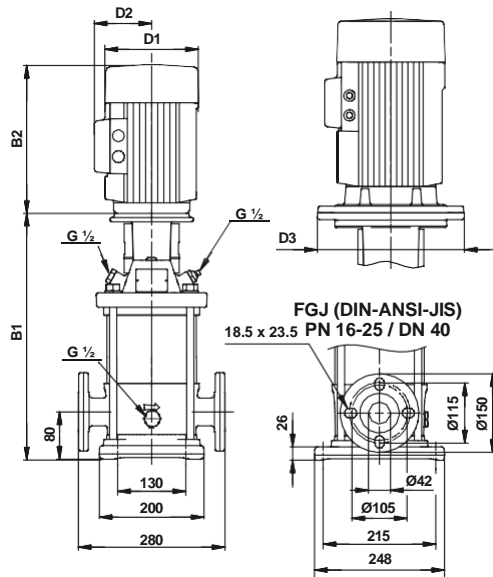

Pump Type	H.P.	kW	Q	n = 2900 rpm						
				I/min	116.7	133.3	150.0	166.7	183.3	200.0
				m ³ /h	7.0	8.0	9.0	10.0	11.0	12.0
LCRI, LCRN 10/1	0.50	0.37	H mts.	10	9	8	8	7	6	
LCRI, LCRN 10/2	1.00	0.75		19	18	17	16	14	12	
LCRI, LCRN 10/3	1.50	1.10		29	28	26	24	22	19	
LCRI, LCRN 10/4	2.00	1.50		38	37	34	32	29	26	
LCRI, LCRN 10/5	3.00	2.20		48	47	44	41	38	34	
LCRI, LCRN 10/6	3.00	2.20		58	56	53	49	45	40	
LCRI, LCRN 10/7	4.00	3.00		68	65	62	57	52	47	
LCRI, LCRN 10/8	4.00	3.00		78	75	70	65	60	53	
LCRI, LCRN 10/9	4.00	3.00		88	84	79	73	66	59	
LCRI, LCRN 10/10	5.50	4.00		97	93	88	82	75	67	
LCRI, LCRN 10/12	5.50	4.00		116	111	105	98	89	80	
LCRI, LCRN 10/14	7.50	5.50		136	130	123	115	105	94	
LCRI, LCRN 10/16	7.50	5.50		154	148	140	130	119	106	
LCRI, LCRN 10/18	10.0	7.50		174	168	158	147	135	122	
LCRI, LCRN 10/20	10.0	7.50	194	186	176	164	150	135		
LCRI, LCRN 10/22	10.0	7.50	213	205	193	180	165	148		

Dimensions & Weights of LCRI, LCRN Pump

Pump type	Dimensions [mm]					Net weight [kg]	Gross weight [kg]	Gross volume [m ³]
	DIN flange		D1	D2	D3			
	B1	B1+B2						
LCRI, LCRN 10/1	353	566	143	106	-	32.0	46.0	0.1428
LCRI, LCRN 10/2	357	621	160	113	-	34.0	48.0	0.1428
LCRI, LCRN 10/3	387	651	160	113	-	38.0	52.0	0.1428
LCRI, LCRN 10/4	433	711	165	130	-	46.0	60.0	0.1428
LCRI, LCRN 10/5	463	741	165	130	-	47.0	61.0	0.1428
LCRI, LCRN 10/6	493	771	165	130	-	48.0	62.0	0.1428
LCRI, LCRN 10/7	528	832	194	140	-	54.0	80.0	0.2650
LCRI, LCRN 10/8	558	862	194	140	-	55.0	81.0	0.2650
LCRI, LCRN 10/9	588	892	194	140	-	56.0	82.0	0.2650
LCRI, LCRN 10/10	618	968	220	150	-	68.0	94.0	0.2650
LCRI, LCRN 10/12	678	1028	220	150	-	70.0	96.0	0.2650
LCRI, LCRN 10/14	770	1180	262	177	300	92.0	121.0	0.2996
LCRI, LCRN 10/16	830	1240	262	177	300	94.0	128.0	0.3458
LCRI, LCRN 10/18	890	1300	262	177	300	99.0	133.0	0.3458
LCRI, LCRN 10/20	950	1360	262	177	300	101.0	135.0	0.3458
LCRI, LCRN 10/22	1010	1420	262	177	300	104.0	138.0	0.3458

Performance Curves

Vertical multistage centrifugal pumps

LCRI, LCRN 10

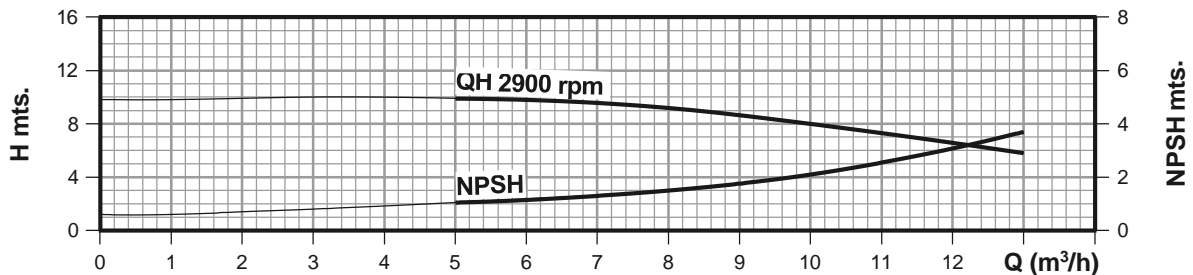
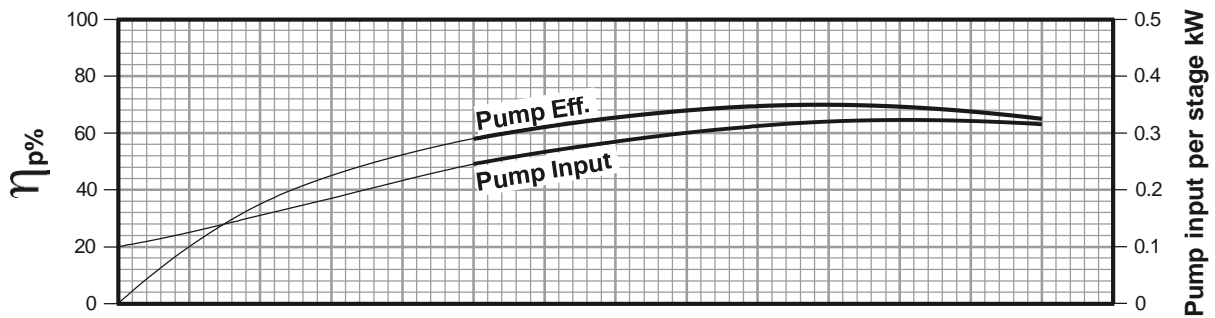
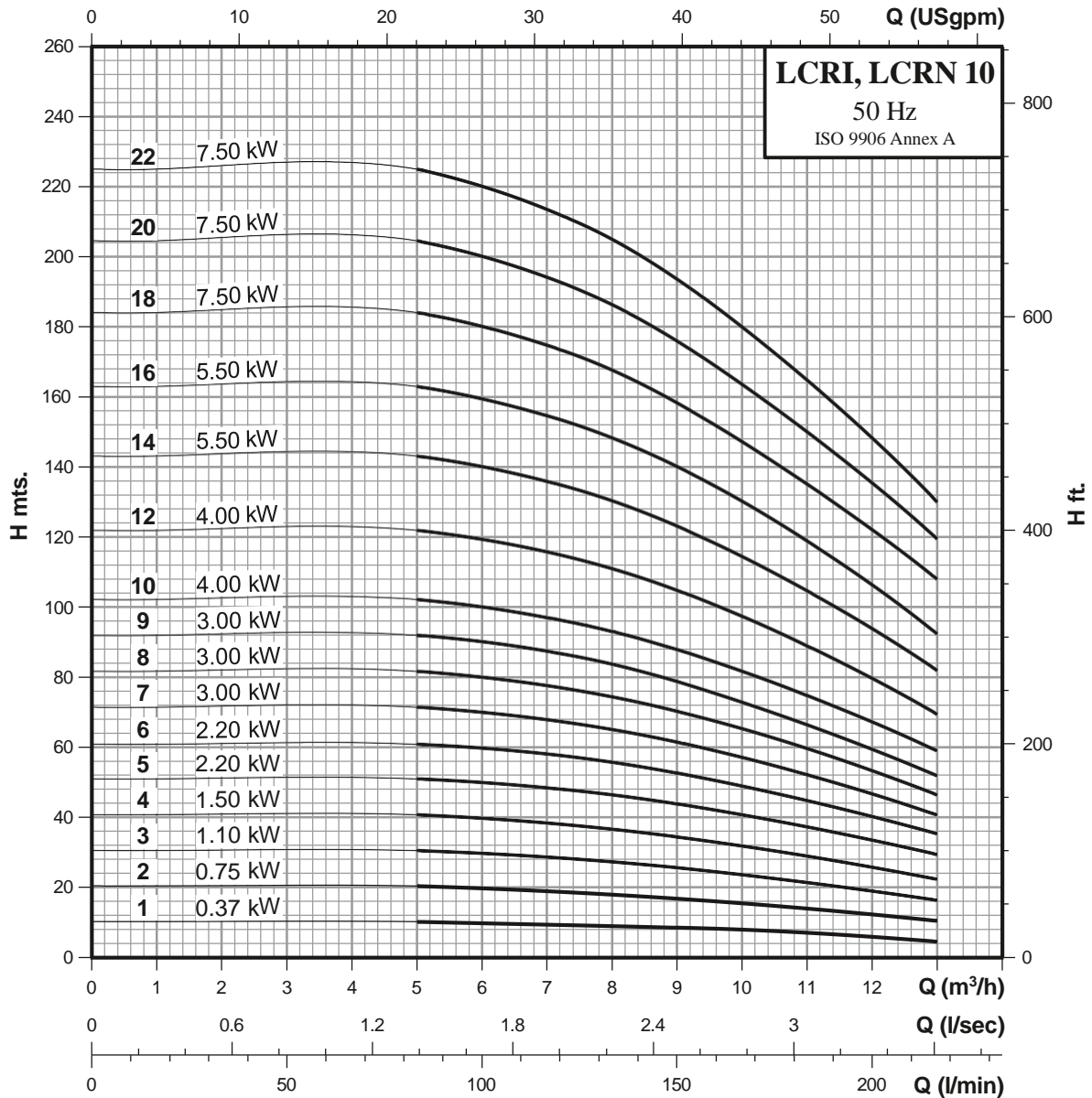

Technical Data

Vertical multistage centrifugal pumps

LCR 15

Performance Chart

Pump Type	H.P.	kW	Q l/min m ³ /h	n = 2900 rpm					
				233.3	250.0	266.7	300.0	333.3	366.7
				14.0	15.0	16.0	18.0	20.0	22.0
LCR 15/1	1.50	1.10	H mts.	12	12	11	11	10	9
LCR 15/2	3.00	2.20		25	24	23	22	20	18
LCR 15/3	4.00	3.00		37	36	35	32	30	26
LCR 15/4	5.50	4.00		50	48	47	44	39	35
LCR 15/5	5.50	4.00		62	60	59	54	49	44
LCR 15/6	7.50	5.50		74	72	69	65	58	52
LCR 15/7	7.50	5.50		87	84	82	76	70	62
LCR 15/8	10.0	7.50		99	96	93	87	79	70
LCR 15/9	10.0	7.50		112	108	105	98	89	80
LCR 15/10	15.0	11.0		124	121	117	109	99	89
LCR 15/12	15.0	11.0		149	146	140	131	119	106
LCR 15/14	15.0	11.0		174	170	163	152	139	124
LCR 15/17	20.0	15.0		211	206	198	185	169	151

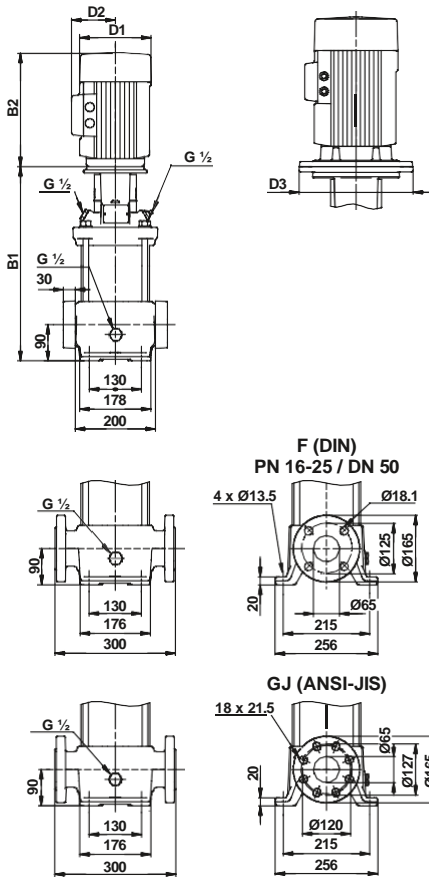

Dimensions & Weights of LCR Pump

Pump type	Dimensions [mm]					Net weight [kg]	Gross weight [kg]	Gross volume [m ³]
	DIN flange		D1	D2	D3			
	B1	B1+B2						
LCR 15/1	400	664	160	113	-	42.0	56.0	0.1428
LCR 15/2	415	693	165	130	-	50.0	64.0	0.1428
LCR 15/3	465	769	194	140	-	55.0	81.0	0.2650
LCR 15/4	510	860	220	150	-	68.0	94.0	0.2650
LCR 15/5	555	905	220	150	-	69.0	95.0	0.2650
LCR 15/6	632	1042	262	177	300	91.0	117.0	0.2650
LCR 15/7	677	1087	262	177	300	93.0	122.0	0.2996
LCR 15/8	722	1132	262	177	300	97.0	126.0	0.2996
LCR 15/9	767	1177	262	177	300	98.0	127.0	0.2996
LCR 15/10	889	1431	304	225	350	130.0	176.0	0.4671
LCR 15/12	979	1521	304	225	350	134.0	187.0	0.5402
LCR 15/14	1069	1611	304	225	350	138.0	191.0	0.5402
LCR 15/17	1204	1746	304	225	350	157.0	210.0	0.5402

Performance Curves

Vertical multistage centrifugal pumps

LCR 15

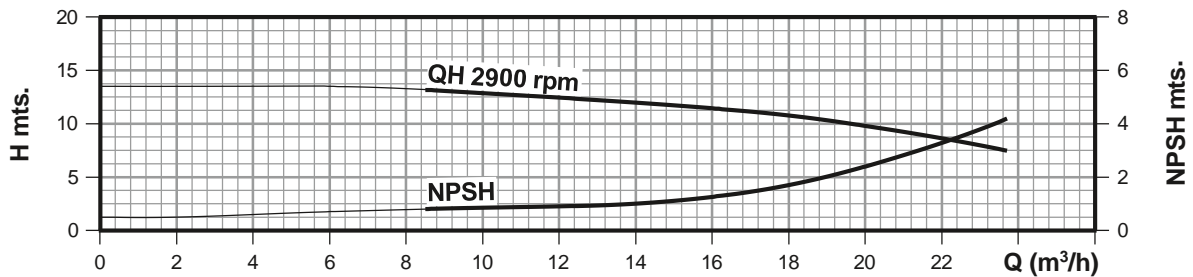
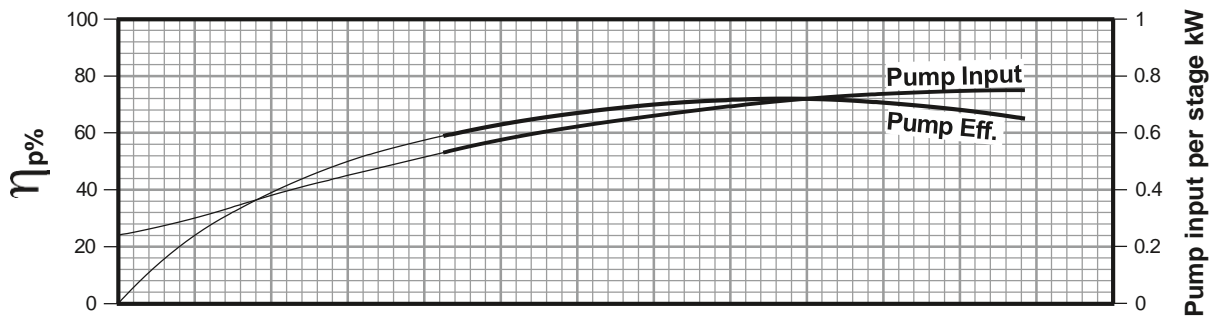
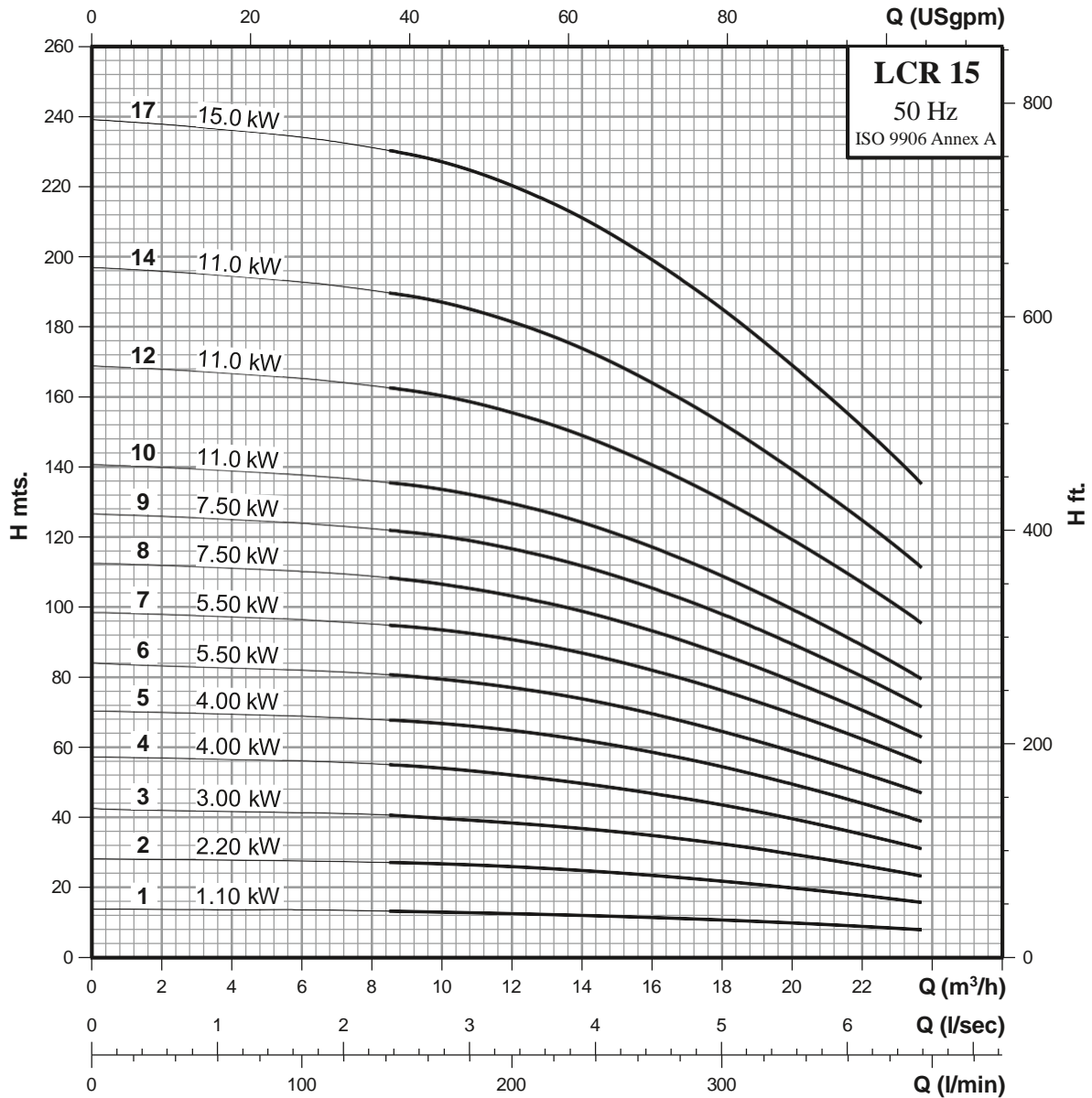

Technical Data

Vertical multistage centrifugal pumps

LCRI, LCRN 15

Performance Chart

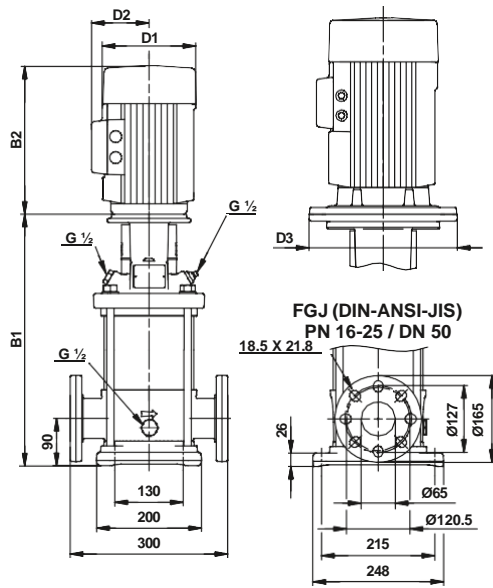

Pump Type	H.P.	kW	Q	n = 2900 rpm						
				l/min	233.3	250.0	266.7	300.0	333.3	366.7
				m ³ /h	14.0	15.0	16.0	18.0	20.0	22.0
LCRI, LCRN 15/1	1.50	1.10	H mts.	12	12	11	11	10	9	
LCRI, LCRN 15/2	3.00	2.20		25	24	23	22	20	18	
LCRI, LCRN 15/3	4.00	3.00		37	36	35	32	30	26	
LCRI, LCRN 15/4	5.50	4.00		50	48	47	44	39	35	
LCRI, LCRN 15/5	5.50	4.00		62	60	59	54	49	44	
LCRI, LCRN 15/6	7.50	5.50		74	72	69	65	58	52	
LCRI, LCRN 15/7	7.50	5.50		87	84	82	76	70	62	
LCRI, LCRN 15/8	10.0	7.50		99	96	93	87	79	70	
LCRI, LCRN 15/9	10.0	7.50		112	108	105	98	89	80	
LCRI, LCRN 15/10	15.0	11.0		124	121	117	109	99	89	
LCRI, LCRN 15/12	15.0	11.0		149	146	140	131	119	106	
LCRI, LCRN 15/14	15.0	11.0		174	170	163	152	139	124	
LCRI, LCRN 15/17	20.0	15.0		211	206	198	185	169	151	

Dimensions & Weights of LCRI, LCRN Pump

Pump type	Dimensions [mm]					Net weight [kg]	Gross weight [kg]	Gross volume [m ³]
	DIN flange		D1	D2	D3			
	B1	B1+B2						
LCRI, LCRN 15/1	400	664	160	113	-	42.0	56.0	0.1428
LCRI, LCRN 15/2	415	693	165	130	-	50.0	64.0	0.1428
LCRI, LCRN 15/3	465	769	194	140	-	55.0	81.0	0.2650
LCRI, LCRN 15/4	510	860	220	150	-	68.0	94.0	0.2650
LCRI, LCRN 15/5	555	905	220	150	-	69.0	95.0	0.2650
LCRI, LCRN 15/6	632	1042	262	177	300	91.0	117.0	0.2650
LCRI, LCRN 15/7	677	1087	262	177	300	93.0	122.0	0.2996
LCRI, LCRN 15/8	722	1132	262	177	300	97.0	126.0	0.2996
LCRI, LCRN 15/9	767	1177	262	177	300	98.0	127.0	0.2996
LCRI, LCRN 15/10	889	1431	304	225	350	130.0	176.0	0.4671
LCRI, LCRN 15/12	979	1521	304	225	350	134.0	187.0	0.5402
LCRI, LCRN 15/14	1069	1611	304	225	350	138.0	191.0	0.5402
LCRI, LCRN 15/17	1204	1746	304	225	350	157.0	210.0	0.5402

Performance Curves

Vertical multistage centrifugal pumps

LCRI, LCRN 15

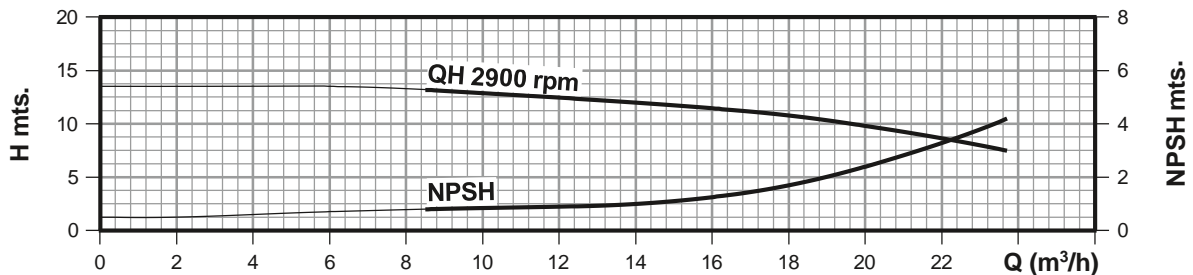
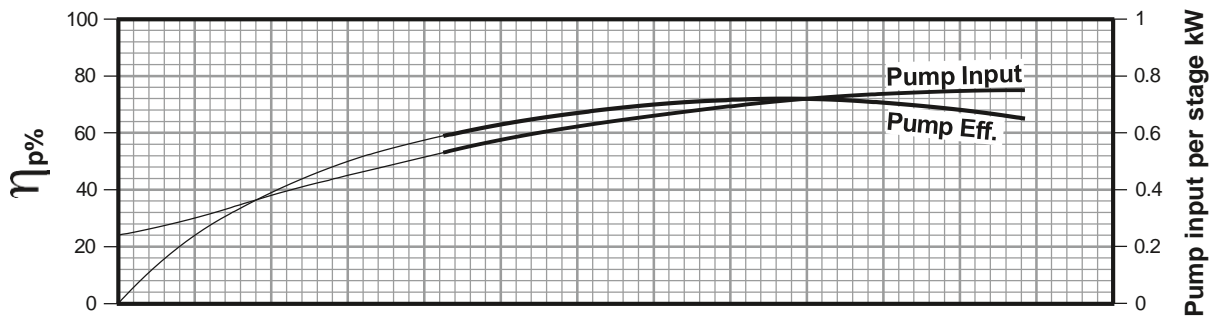
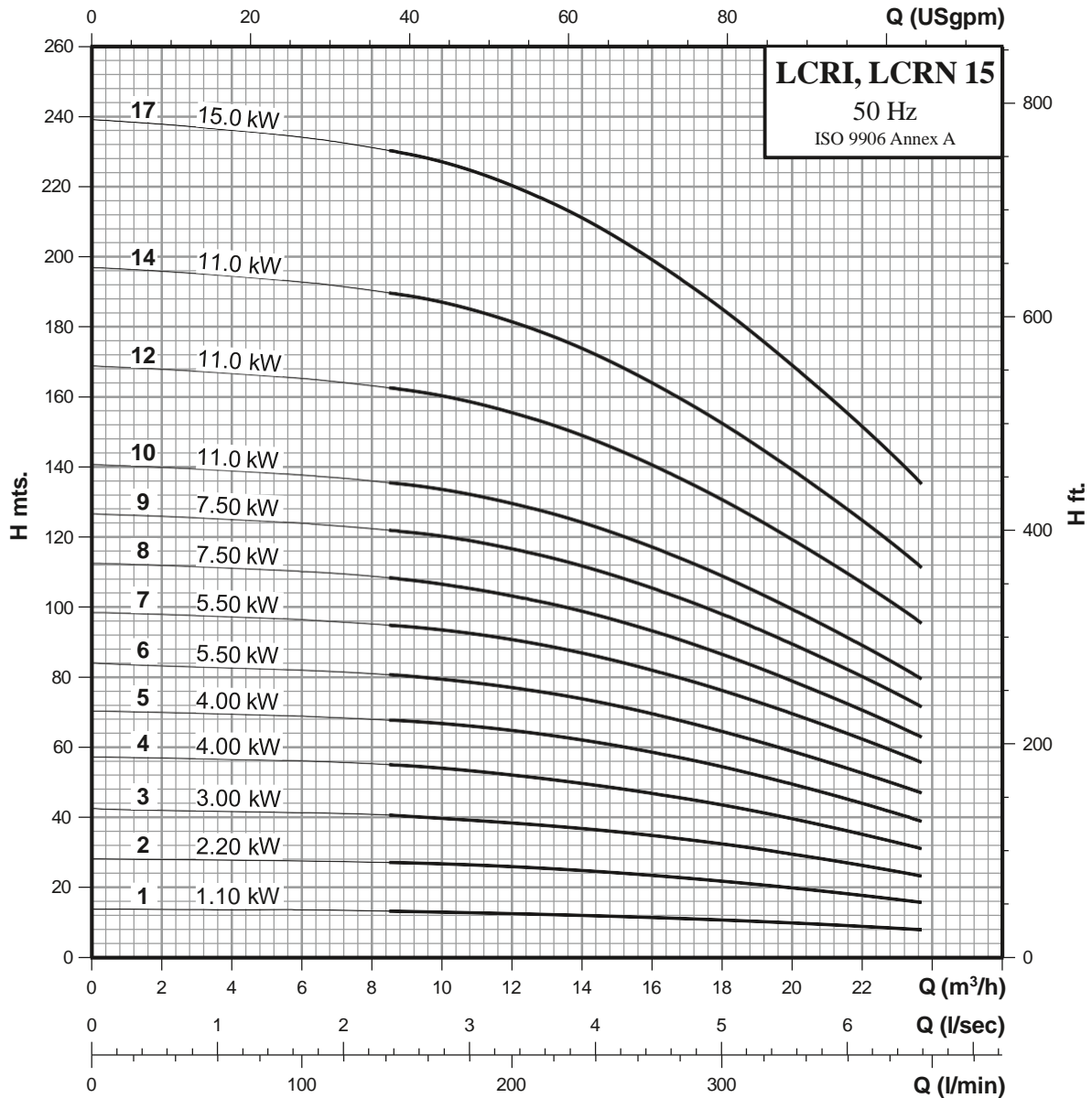

Technical Data

Vertical multistage centrifugal pumps

LCR 20

Performance Chart

Pump Type	H.P.	kW	Q l/min m ³ /h	n = 2900 rpm					
				233.3	300.0	333.3	366.7	400.0	433.3
				14.0	18.0	20.0	22.0	24.0	26.0
LCR 20/1	1.50	1.10	H	13	12	12	11	10	8
LCR 20/2	3.00	2.20	mts.	27	25	24	23	20	18
LCR 20/3	5.50	4.00		41	38	36	34	31	27
LCR 20/4	7.50	5.50		56	52	49	46	42	38
LCR 20/5	7.50	5.50		69	64	60	56	52	46
LCR 20/6	10.0	7.50		83	77	73	69	63	57
LCR 20/7	10.0	7.50		97	90	85	80	74	66
LCR 20/8	15.0	11.0		111	104	98	92	85	76
LCR 20/10	15.0	11.0		138	128	122	114	104	94
LCR 20/12	20.0	15.0		167	155	148	138	128	114
LCR 20/14	20.0	15.0		193	180	171	160	147	133
LCR 20/17	25.0	18.5		236	220	208	196	180	162

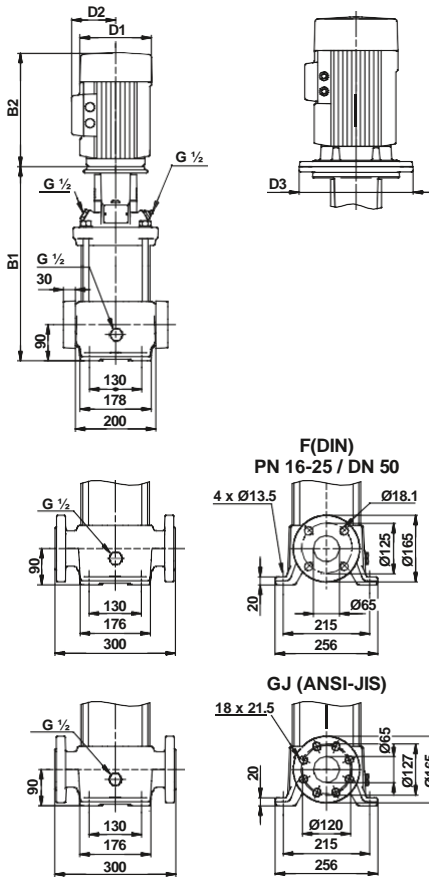

Dimensions & Weights of LCR Pump

Pump type	Dimensions [mm]					Net weight [kg]	Gross weight [kg]	Gross volume [m ³]
	DIN flange		D1	D2	D3			
	B1	B1+B2						
LCR 20/1	400	664	160	113	-	42.0	56.0	0.1428
LCR 20/2	415	693	165	130	-	50.0	64.0	0.1428
LCR 20/3	465	815	220	150	-	66.0	92.0	0.2650
LCR 20/4	542	952	262	177	300	88.0	114.0	0.2650
LCR 20/5	587	997	262	177	300	90.0	116.0	0.2650
LCR 20/6	632	1042	262	177	300	93.0	119.0	0.2650
LCR 20/7	677	1087	262	177	300	95.0	124.0	0.2996
LCR 20/8	799	1341	304	225	350	127.0	173.0	0.4671
LCR 20/10	889	1431	304	225	350	130.0	176.0	0.4671
LCR 20/12	979	1521	304	225	350	148.0	201.0	0.5402
LCR 20/14	1069	1611	304	225	350	152.0	205.0	0.5402
LCR 20/17	1204	1746	304	225	350	187.0	240.0	0.5402

Performance Curves

Vertical multistage centrifugal pumps

LCR 20

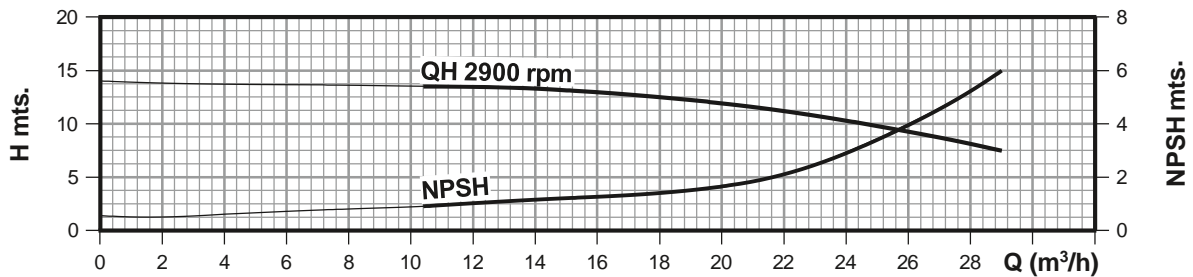
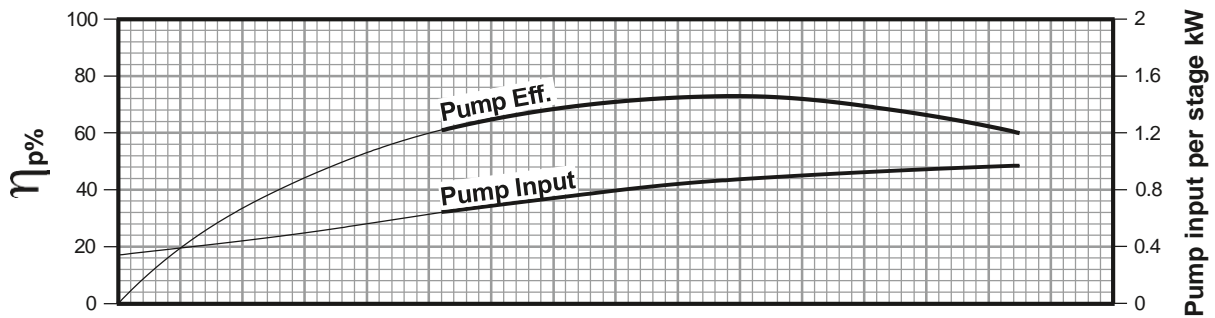
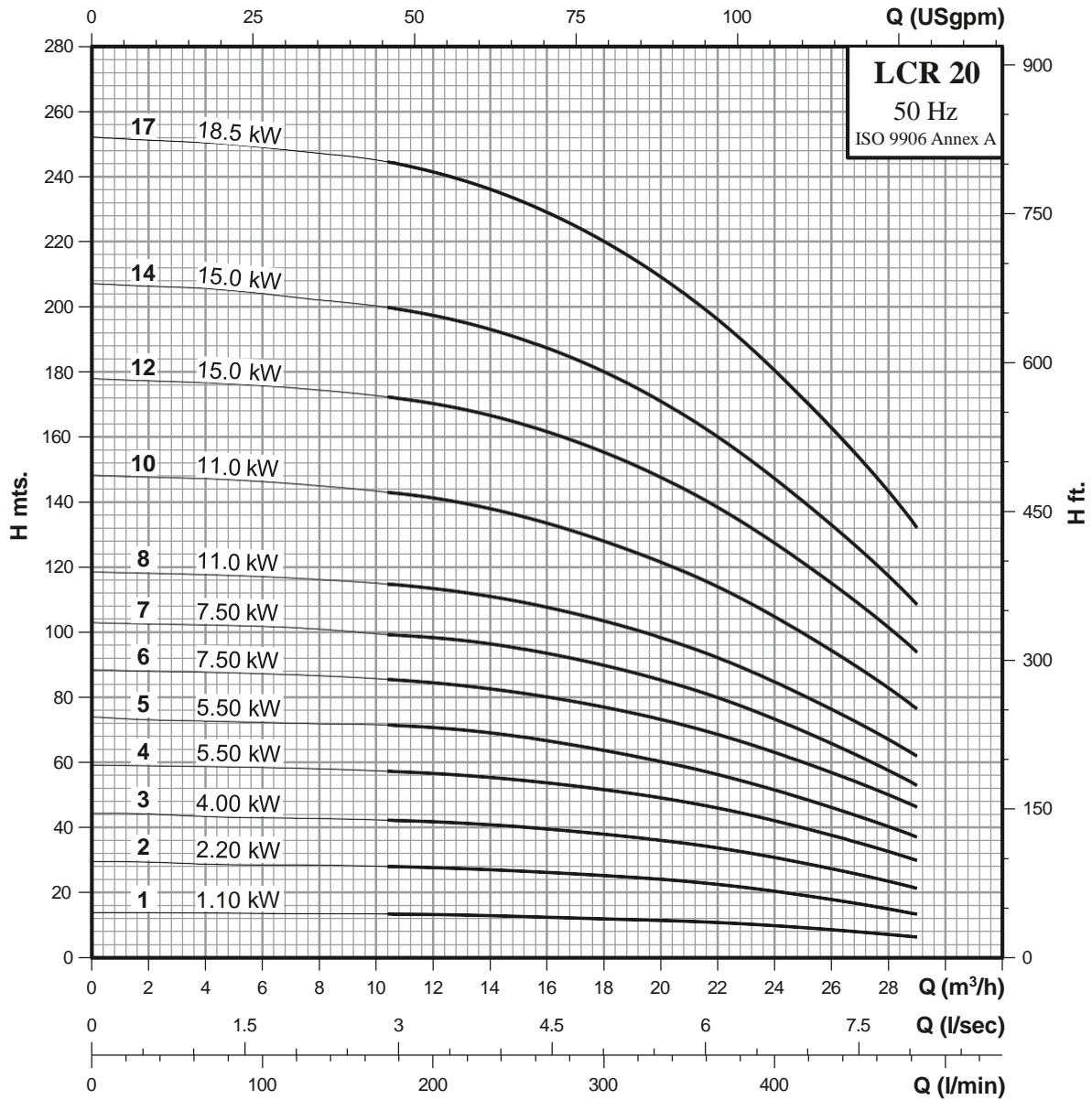

Technical Data

Vertical multistage centrifugal pumps

LCRI, LCRN 20

Performance Chart

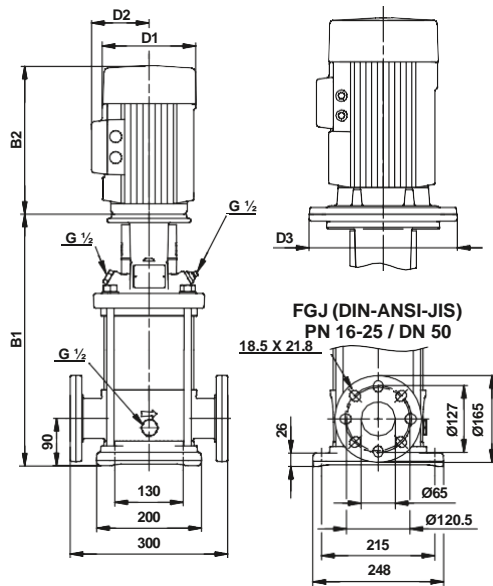

Pump Type	H.P.	kW	Q	n = 2900 rpm						
				l/min	233.3	300.0	333.3	366.7	400.0	433.3
				m ³ /h	14.0	18.0	20.0	22.0	24.0	26.0
LCRI, LCRN 20/1	1.50	1.10	H mts.	13	12	12	11	10	8	
LCRI, LCRN 20/2	3.00	2.20		27	25	24	23	20	18	
LCRI, LCRN 20/3	5.50	4.00		41	38	36	34	31	27	
LCRI, LCRN 20/4	7.50	5.50		56	52	49	46	42	38	
LCRI, LCRN 20/5	7.50	5.50		69	64	60	56	52	46	
LCRI, LCRN 20/6	10.0	7.50		83	77	73	69	63	57	
LCRI, LCRN 20/7	10.0	7.50		97	90	85	80	74	66	
LCRI, LCRN 20/8	15.0	11.0		111	104	98	92	85	76	
LCRI, LCRN 20/10	15.0	11.0		138	128	122	114	104	94	
LCRI, LCRN 20/12	20.0	15.0		167	155	148	138	128	114	
LCRI, LCRN 20/14	20.0	15.0		193	180	171	160	147	133	
LCRI, LCRN 20/17	25.0	18.5		236	220	208	196	180	162	

Dimensions & Weights of LCRI, LCRN Pump

Pump type	Dimensions [mm]					Net weight [kg]	Gross weight [kg]	Gross volume [m ³]
	DIN flange		D1	D2	D3			
	B1	B1+B2						
LCRI, LCRN 20/1	397	661	160	113	-	39.0	53.0	0.1428
LCRI, LCRN 20/2	413	691	165	130	-	47.0	61.0	0.1428
LCRI, LCRN 20/3	463	813	220	150	-	63.0	89.0	0.2650
LCRI, LCRN 20/4	540	950	262	177	300	85.0	111.0	0.2650
LCRI, LCRN 20/5	585	995	262	177	300	87.0	113.0	0.2650
LCRI, LCRN 20/6	630	1040	262	177	300	90.0	116.0	0.2650
LCRI, LCRN 20/7	675	1085	262	177	300	92.0	121.0	0.2996
LCRI, LCRN 20/8	797	1339	304	225	350	123.0	169.0	0.4671
LCRI, LCRN 20/10	887	1429	304	225	350	127.0	173.0	0.4671
LCRI, LCRN 20/12	977	1519	304	225	350	145.0	198.0	0.5402
LCRI, LCRN 20/14	1067	1609	304	225	350	148.0	201.0	0.5402
LCRI, LCRN 20/17	1202	1744	304	225	350	183.0	236.0	0.5402

Performance Curves

Vertical multistage centrifugal pumps

LCRI, LCRN 20

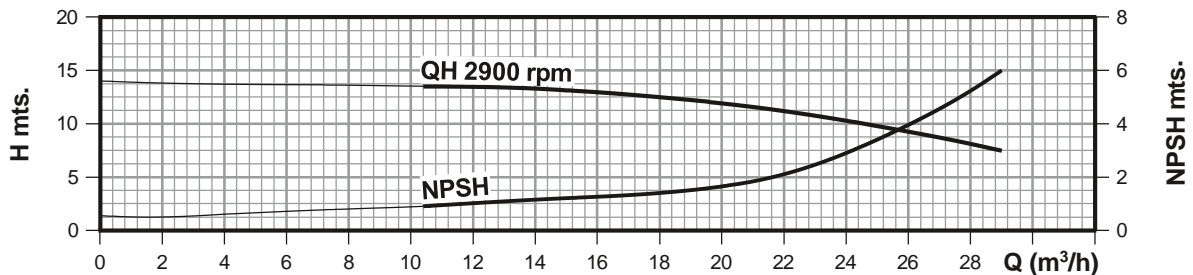
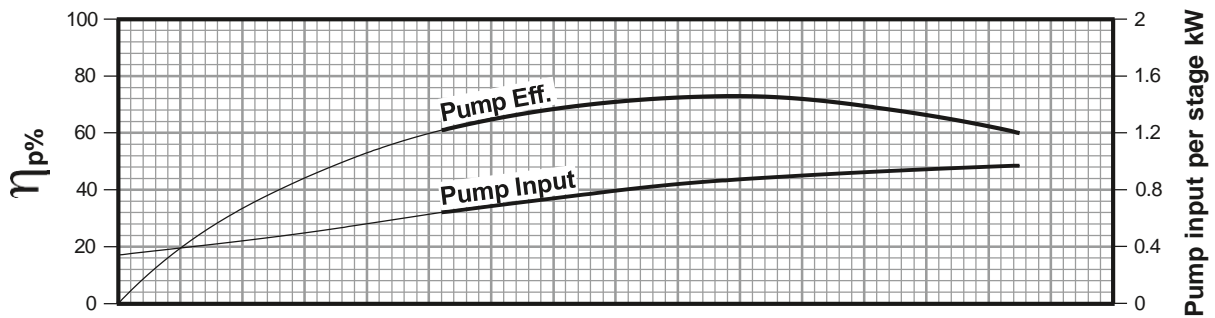
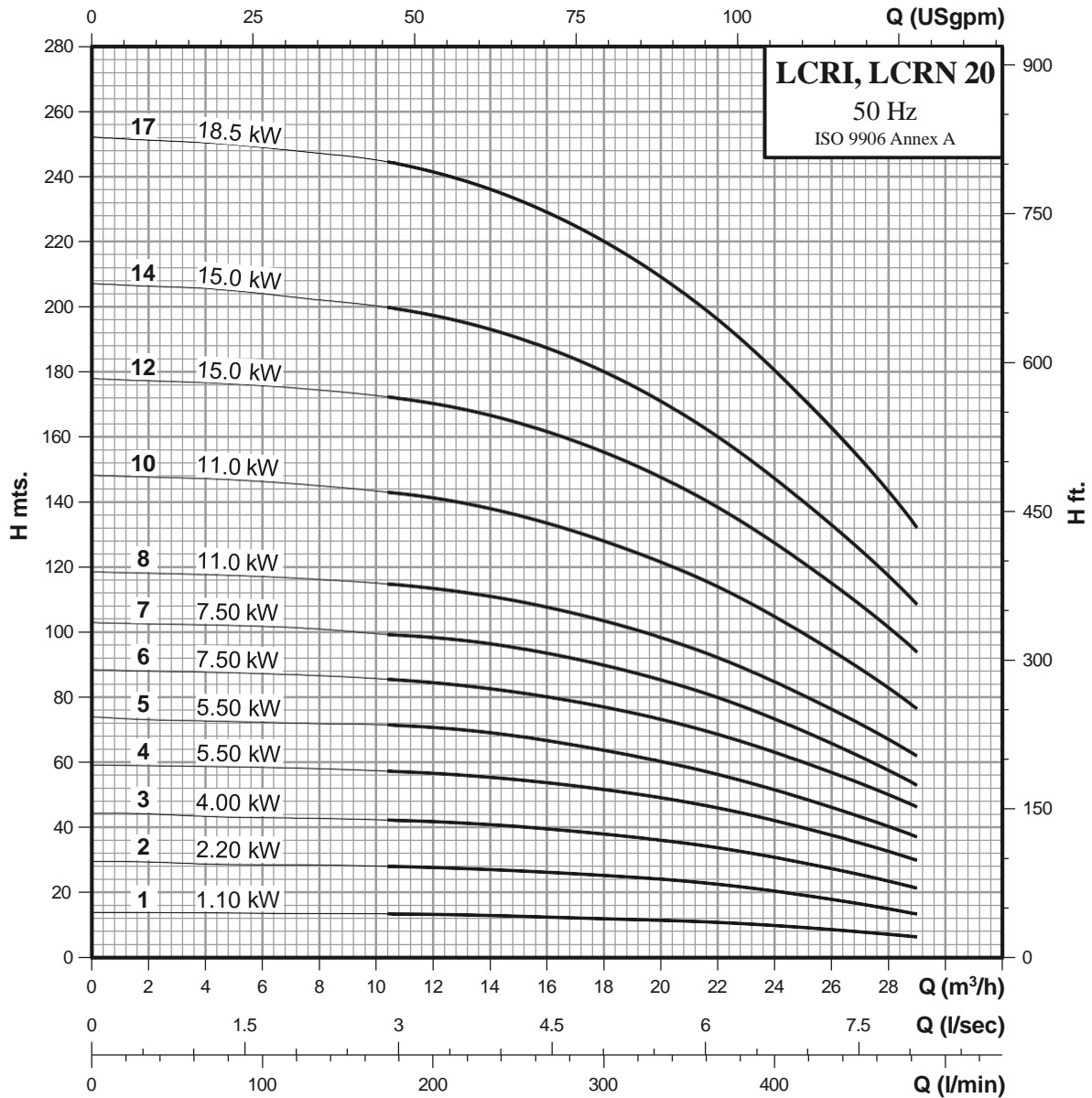

Technical Data

Vertical multistage centrifugal pumps

LCR 32

Performance Chart

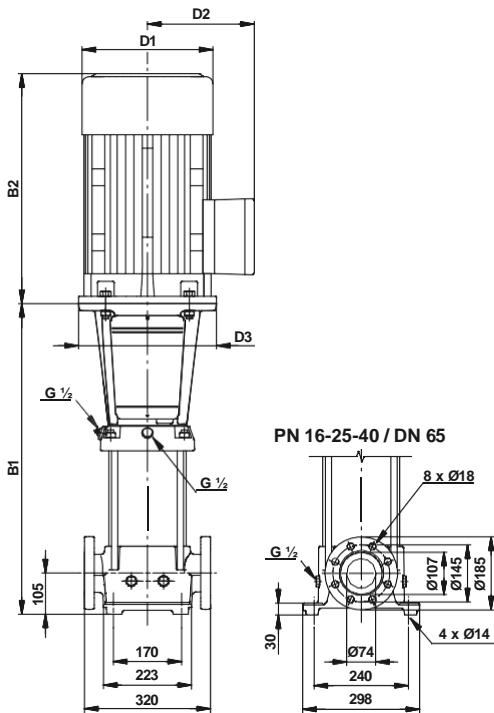

Pump Type	H.P.	kW	Q	n = 2900 rpm					
				l/min	333.3	400.0	466.7	533.3	600.0
				m ³ /h	15.0	20.0	24.0	28.0	32.0
LCR 32/1-1	2.00	1.50	H mts.	16	15	13	12	10	8
LCR 32/1	3.00	2.20		19	18	16	15	13	11
LCR 32/2-2	4.00	3.00		31	29	26	24	21	17
LCR 32/2	5.50	4.00		38	35	33	31	27	23
LCR 32/3-2	7.50	5.50		51	48	44	41	36	30
LCR 32/3	7.50	5.50		57	54	51	47	42	36
LCR 32/4-2	10.0	7.50		69	66	61	56	50	42
LCR 32/4	10.0	7.50		76	72	68	63	56	49
LCR 32/5-2	15.0	11.0		89	85	80	74	66	56
LCR 32/5	15.0	11.0		96	91	85	79	72	63
LCR 32/6-2	15.0	11.0		107	102	96	89	79	69
LCR 32/6	15.0	11.0		114	109	103	96	86	76
LCR 32/7-2	20.0	15.0		127	120	113	105	94	82
LCR 32/7	20.0	15.0		133	127	120	112	102	90
LCR 32/8-2	20.0	15.0		146	138	130	120	108	94
LCR 32/8	20.0	15.0		151	143	135	126	113	100
LCR 32/9-2	25.0	18.5		165	157	148	137	123	108
LCR 32/9	25.0	18.5		172	163	153	143	130	115
LCR 32/10-2	25.0	18.5		184	175	165	153	137	120
LCR 32/10	25.0	18.5		191	182	171	159	144	127
LCR 32/11-2	30.0	22.0	204	194	183	170	153	134	
LCR 32/11	30.0	22.0	210	200	188	176	159	141	
LCR 32/12-2	30.0	22.0	223	212	200	187	168	148	
LCR 32/12	30.0	22.0	229	217	206	193	176	155	
LCR 32/13-2	40.0	30.0	244	233	221	208	188	167	
LCR 32/13	40.0	30.0	250	239	227	213	194	172	
LCR 32/14-2	40.0	30.0	263	251	237	221	200	177	
LCR 32/14	40.0	30.0	270	257	244	228	208	184	

Dimensions & Weights of LCR Pump

Pump type	Dimensions [mm]					Net weight [kg]	Gross weight [kg]	Gross volume [m ³]
	DIN flange		D1	D2	D3			
	B1	B1+B2						
LCR 32/1-1	505	783	165	130	135	61.0	119.0	0.3745
LCR 32/1	505	783	165	130	135	62.0	120.0	0.3745
LCR 32/2-2	575	879	194	140	-	76.0	134.0	0.3745
LCR 32/2	575	925	220	150	158	87.0	145.0	0.3745
LCR 32/3-2	645	1055	262	177	298	107.0	165.0	0.3745
LCR 32/3	645	1055	262	177	298	107.0	165.0	0.3745
LCR 32/4-2	715	1125	262	177	298	117.0	175.0	0.3745
LCR 32/4	715	1125	262	177	298	117.0	175.0	0.3745
LCR 32/5-2	895	1437	304	225	350	155.0	225.0	0.4495
LCR 32/5	895	1437	304	225	350	155.0	225.0	0.4495
LCR 32/6-2	965	1507	304	225	350	158.0	228.0	0.4495
LCR 32/6	965	1507	304	225	350	158.0	228.0	0.4495
LCR 32/7-2	1035	1577	304	225	350	175.0	245.0	0.4495
LCR 32/7	1035	1577	304	225	350	175.0	245.0	0.4495
LCR 32/8-2	1105	1647	304	225	350	178.0	248.0	0.4495
LCR 32/8	1105	1647	304	225	350	178.0	248.0	0.4495
LCR 32/9-2	1175	1717	304	225	350	211.0	294.0	0.5370
LCR 32/9	1175	1717	304	225	350	211.0	294.0	0.5370
LCR 32/10-2	1245	1787	304	225	350	214.0	297.0	0.5370
LCR 32/10	1245	1787	304	225	350	214.0	297.0	0.5370
LCR 32/11-2	1315	1925	363	262	350	250.0	333.0	0.5370
LCR 32/11	1315	1925	363	262	350	250.0	333.0	0.5370
LCR 32/12-2	1385	1995	363	262	350	254.0	337.0	0.5370
LCR 32/12	1385	1995	363	262	350	254.0	337.0	0.5370
LCR 32/13-2	1455	2101	415	300	400	322.0	419.0	0.6245
LCR 32/13	1455	2101	415	300	400	322.0	419.0	0.6245
LCR 32/14-2	1525	2171	415	300	400	325.0	422.0	0.6245
LCR 32/14	1525	2171	415	300	400	325.0	422.0	0.6245

Performance Curves

Vertical multistage centrifugal pumps

LCR 32

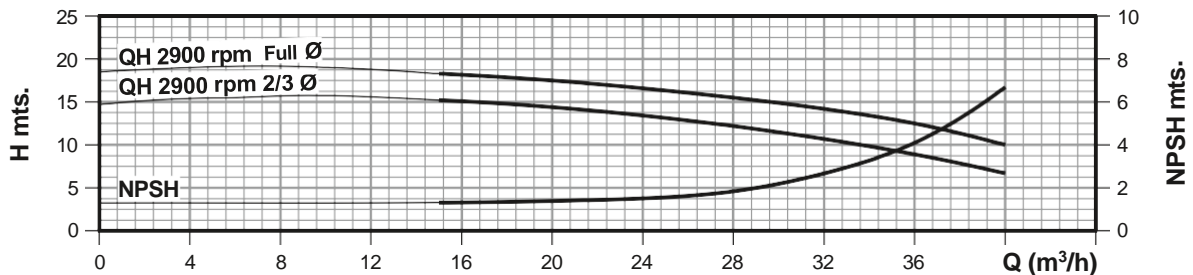
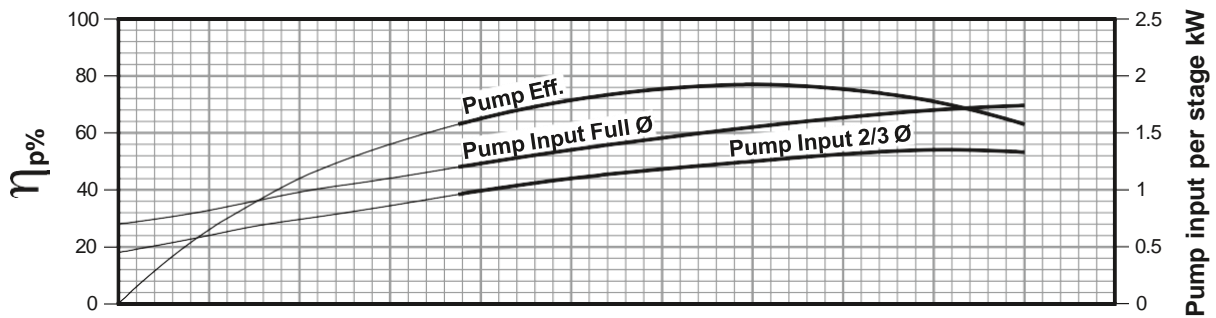
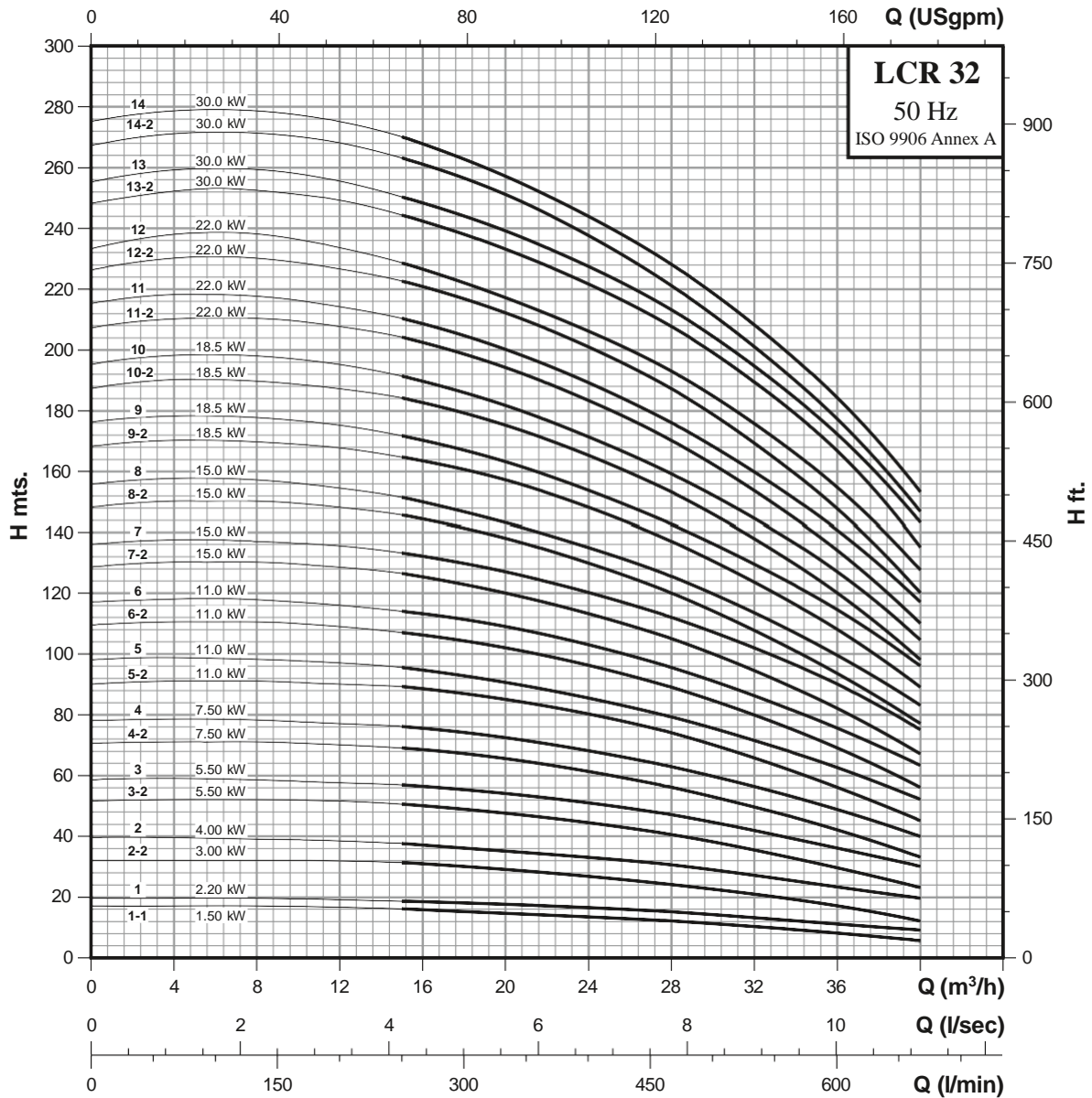

Technical Data

Vertical multistage centrifugal pumps

LCRI, LCRN 32

Performance Chart

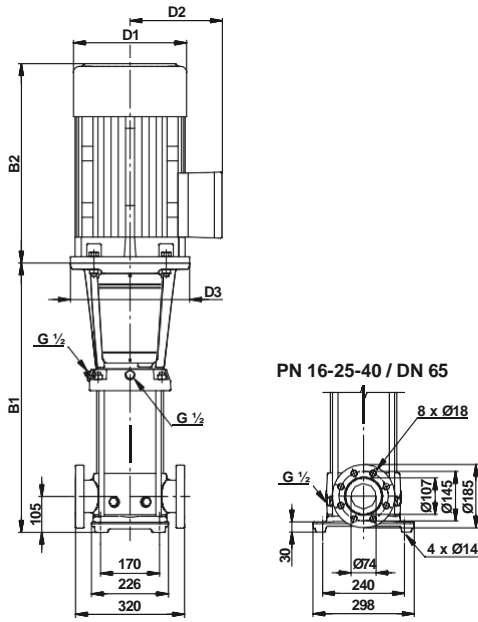

Pump Type	H.P.	kW	Q	n = 2900 rpm						
				l/min	250.0	333.3	400.0	466.7	533.3	600.0
				m ³ /h	15.0	20.0	24.0	28.0	32.0	36.0
LCRI, LCRN 32/1-1	2.00	1.50	H mts.	16	15	13	12	10	8	
LCRI, LCRN 32/1	3.00	2.20		19	18	16	15	13	11	
LCRI, LCRN 32/2-2	4.00	3.00		31	29	26	24	21	17	
LCRI, LCRN 32/2	5.50	4.00		38	35	33	31	27	23	
LCRI, LCRN 32/3-2	7.50	5.50		51	48	44	41	36	30	
LCRI, LCRN 32/3	7.50	5.50		57	54	51	47	42	36	
LCRI, LCRN 32/4-2	10.0	7.50		69	66	61	56	50	42	
LCRI, LCRN 32/4	10.0	7.50		76	72	68	63	56	49	
LCRI, LCRN 32/5-2	15.0	11.0		89	85	80	74	66	56	
LCRI, LCRN 32/5	15.0	11.0		96	91	85	79	72	63	
LCRI, LCRN 32/6-2	15.0	11.0		107	102	96	89	79	69	
LCRI, LCRN 32/6	15.0	11.0		114	109	103	96	86	76	
LCRI, LCRN 32/7-2	20.0	15.0		127	120	113	105	94	82	
LCRI, LCRN 32/7	20.0	15.0		133	127	120	112	102	90	
LCRI, LCRN 32/8-2	20.0	15.0		146	138	130	120	108	94	
LCRI, LCRN 32/8	20.0	15.0		151	143	135	126	113	100	
LCRI, LCRN 32/9-2	25.0	18.5		165	157	148	137	123	108	
LCRI, LCRN 32/9	25.0	18.5		172	163	153	143	130	115	
LCRI, LCRN 32/10-2	25.0	18.5		184	175	165	153	137	120	
LCRI, LCRN 32/10	25.0	18.5		191	182	171	159	144	127	
LCRI, LCRN 32/11-2	30.0	22.0	204	194	183	170	153	134		
LCRI, LCRN 32/11	30.0	22.0	210	200	188	176	159	141		
LCRI, LCRN 32/12-2	30.0	22.0	223	212	200	187	168	148		
LCRI, LCRN 32/12	30.0	22.0	229	217	206	193	176	155		
LCRI, LCRN 32/13-2	40.0	30.0	244	233	221	208	188	167		
LCRI, LCRN 32/13	40.0	30.0	250	239	227	213	194	172		
LCRI, LCRN 32/14-2	40.0	30.0	263	251	237	221	200	177		
LCRI, LCRN 32/14	40.0	30.0	270	257	244	228	208	184		

Dimensions & Weights of LCRI, LCRN Pump

Pump type	Dimensions [mm]					Net weight [kg]	Gross weight [kg]	Gross volume [m ³]
	DIN flange		D1	D2	D3			
	B1	B1+B2						
LCRI, LCRN 32/1-1	505	783	165	130	135	61.0	119.0	0.3745
LCRI, LCRN 32/1	505	783	165	130	135	62.0	120.0	0.3745
LCRI, LCRN 32/2-2	575	879	194	140	-	76.0	134.0	0.3745
LCRI, LCRN 32/2	575	925	220	150	158	87.0	145.0	0.3745
LCRI, LCRN 32/3-2	645	1055	262	177	298	107.0	165.0	0.3745
LCRI, LCRN 32/3	645	1055	262	177	298	107.0	165.0	0.3745
LCRI, LCRN 32/4-2	715	1125	262	177	298	117.0	175.0	0.3745
LCRI, LCRN 32/4	715	1125	262	177	298	117.0	175.0	0.3745
LCRI, LCRN 32/5-2	895	1437	304	225	350	155.0	225.0	0.4495
LCRI, LCRN 32/5	895	1437	304	225	350	155.0	225.0	0.4495
LCRI, LCRN 32/6-2	965	1507	304	225	350	158.0	228.0	0.4495
LCRI, LCRN 32/6	965	1507	304	225	350	158.0	228.0	0.4495
LCRI, LCRN 32/7-2	1035	1577	304	225	350	175.0	245.0	0.4495
LCRI, LCRN 32/7	1035	1577	304	225	350	175.0	245.0	0.4495
LCRI, LCRN 32/8-2	1105	1647	304	225	350	178.0	248.0	0.4495
LCRI, LCRN 32/8	1105	1647	304	225	350	178.0	248.0	0.4495
LCRI, LCRN 32/9-2	1175	1717	304	225	350	211.0	294.0	0.5370
LCRI, LCRN 32/9	1175	1717	304	225	350	211.0	294.0	0.5370
LCRI, LCRN 32/10-2	1245	1787	304	225	350	214.0	297.0	0.5370
LCRI, LCRN 32/10	1245	1787	304	225	350	214.0	297.0	0.5370
LCRI, LCRN 32/11-2	1315	1925	363	262	350	250.0	333.0	0.5370
LCRI, LCRN 32/11	1315	1925	363	262	350	250.0	333.0	0.5370
LCRI, LCRN 32/12-2	1385	1995	363	262	350	254.0	337.0	0.5370
LCRI, LCRN 32/12	1385	1995	363	262	350	254.0	337.0	0.5370
LCRI, LCRN 32/13-2	1455	2101	415	300	400	322.0	419.0	0.6245
LCRI, LCRN 32/13	1455	2101	415	300	400	322.0	419.0	0.6245
LCRI, LCRN 32/14-2	1525	2171	415	300	400	325.0	422.0	0.6245
LCRI, LCRN 32/14	1525	2171	415	300	400	325.0	422.0	0.6245

Performance Curves

Vertical multistage centrifugal pumps

LCRI, LCRN 32

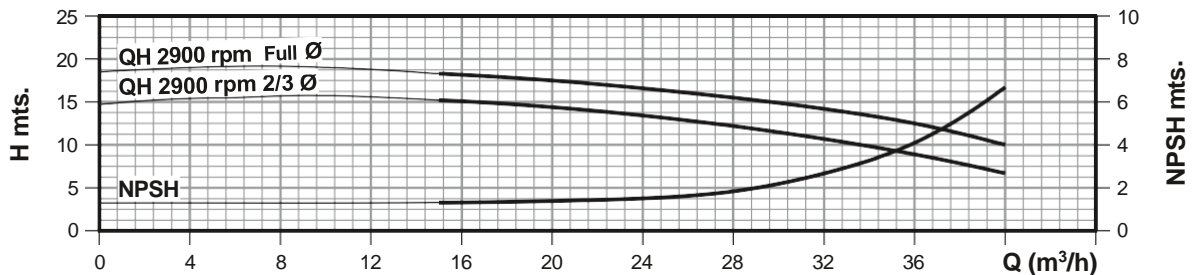
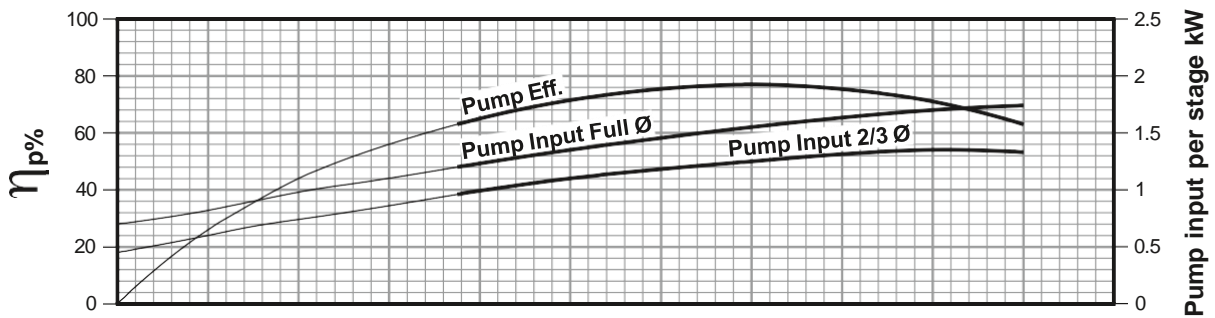
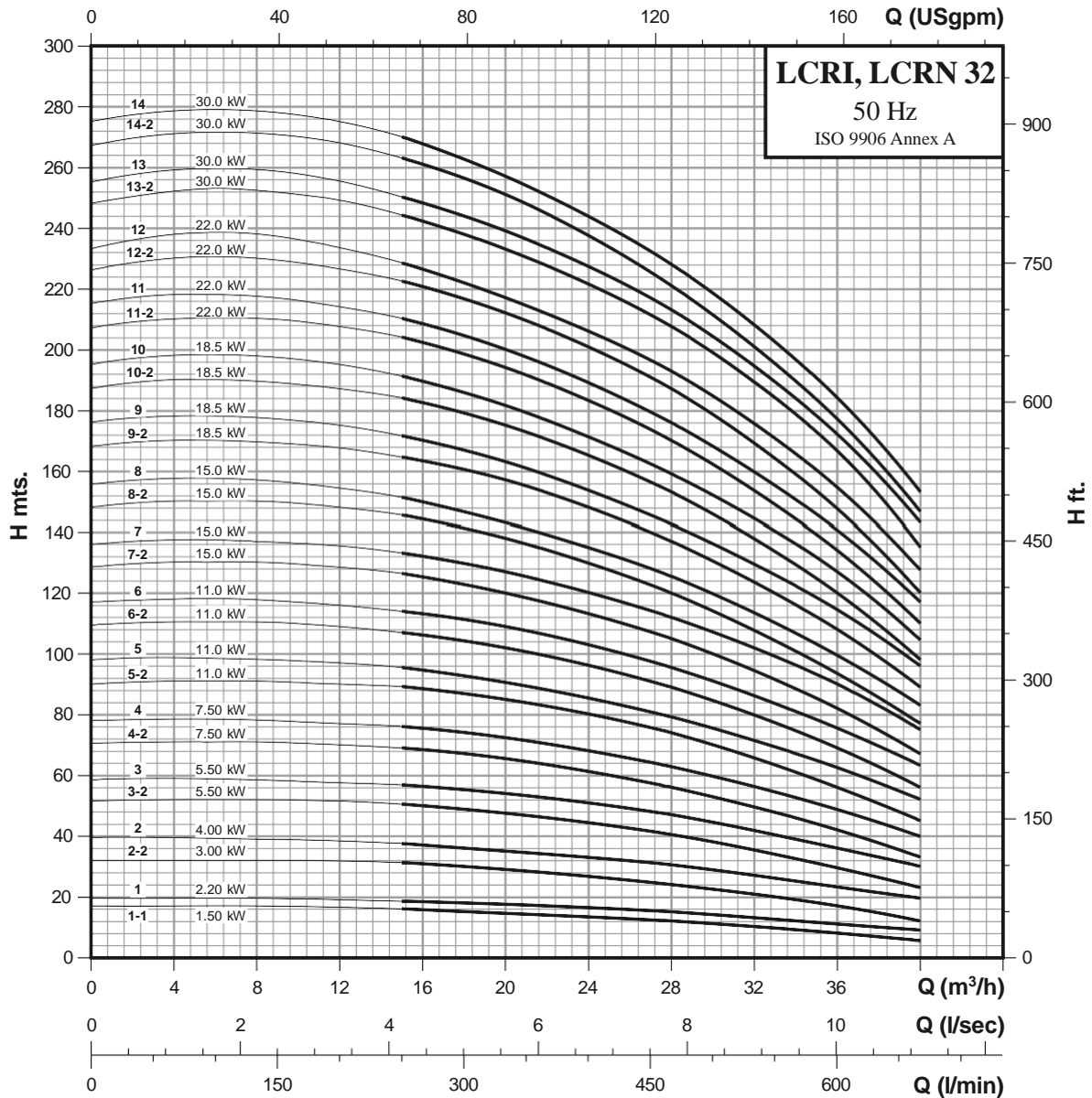

Technical Data

Vertical multistage centrifugal pumps

LCR 45

Performance Chart

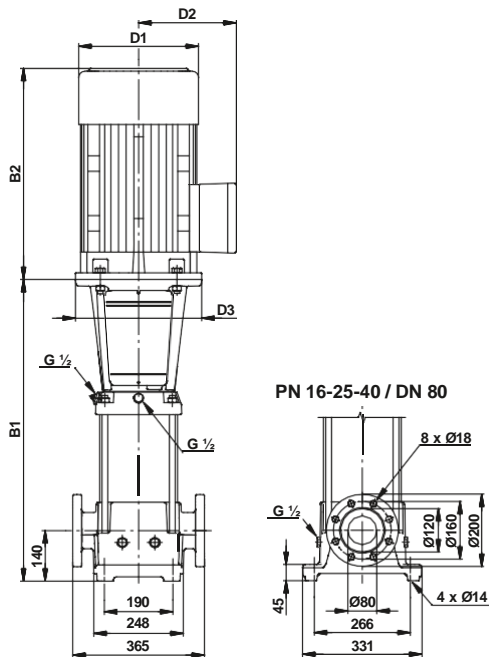

Pump Type	H.P.	kW	Q l/min m ³ /h	n = 2900 rpm					
				366.7	500.0	666.7	750.0	833.3	916.7
				22.0	30.0	40.0	45.0	50.0	55.0
LCR 45/1-1	4.00	3.00	H mts.	20	20	17	15	13	11
LCR 45/1	5.50	4.00		25	24	21	20	18	16
LCR 45/2-2	7.50	5.50		41	39	35	31	27	22
LCR 45/2	10.0	7.50		50	48	43	40	36	32
LCR 45/3-2	15.0	11.0		67	64	57	52	46	39
LCR 45/3	15.0	11.0		76	72	65	60	54	48
LCR 45/4-2	20.0	15.0		93	88	79	73	64	56
LCR 45/4	20.0	15.0		100	95	86	80	72	64
LCR 45/5-2	25.0	18.5		119	113	101	93	84	74
LCR 45/5	25.0	18.5		126	120	108	101	91	80
LCR 45/6-2	30.0	22.0		145	138	124	114	103	90
LCR 45/6	30.0	22.0		152	145	130	120	108	97
LCR 45/7-2	40.0	30.0		170	163	148	137	124	109
LCR 45/7	40.0	30.0		178	171	155	145	132	117
LCR 45/8-2	40.0	30.0		196	187	169	157	142	125
LCR 45/8	40.0	30.0		203	194	175	164	150	133
LCR 45/9-2	40.0	30.0		220	211	191	177	160	142
LCR 45/9	50.0	37.0		229	220	199	185	168	150
LCR 45/10-2	50.0	37.0		246	235	213	198	180	159
LCR 45/10	50.0	37.0		254	242	220	206	188	167
LCR 45/11-2	60.0	45.0	277	263	238	221	201	177	
LCR 45/11	60.0	45.0	285	272	247	230	210	187	
LCR 45/12-2	60.0	45.0	303	289	261	243	220	195	
LCR 45/12	60.0	45.0	313	297	269	251	229	204	
LCR 45/13-2	60.0	45.0	328	314	283	263	239	212	

Dimensions & Weights of LCR Pump

Pump type	Dimensions [mm]					Net weight [kg]	Gross weight [kg]	Gross volume [m ³]
	DIN flange		D1	D2	D3			
	B1	B1+B2						
LCR 45/1-1	559	863	194	140	-	80.0	138.0	0.3745
LCR 45/1	559	909	220	150	158	91.0	149.0	0.3745
LCR 45/2-2	639	1049	262	177	298	108.0	166.0	0.3745
LCR 45/2	639	1049	262	177	298	110.0	168.0	0.3745
LCR 45/3-2	829	1371	304	225	350	149.0	207.0	0.3745
LCR 45/3	829	1371	304	225	350	149.0	219.0	0.4495
LCR 45/4-2	909	1451	304	225	350	169.0	239.0	0.4495
LCR 45/4	909	1451	304	225	350	169.0	239.0	0.4495
LCR 45/5-2	989	1531	304	225	350	204.0	274.0	0.4495
LCR 45/5	989	1531	304	225	350	204.0	274.0	0.4495
LCR 45/6-2	1069	1679	363	262	350	240.0	310.0	0.4495
LCR 45/6	1069	1679	363	262	350	240.0	310.0	0.4495
LCR 45/7-2	1149	1795	415	300	400	321.0	404.0	0.5370
LCR 45/7	1149	1795	415	300	400	321.0	404.0	0.5370
LCR 45/8-2	1229	1875	415	300	400	336.0	419.0	0.5370
LCR 45/8	1229	1875	415	300	400	336.0	419.0	0.5370
LCR 45/9-2	1309	1955	415	300	400	341.0	424.0	0.5370
LCR 45/9	1309	2012	415	300	400	361.0	444.0	0.5370
LCR 45/10-2	1389	2092	415	300	400	366.0	463.0	0.6245
LCR 45/10	1389	2092	415	300	400	366.0	463.0	0.6245
LCR 45/11-2	1469	2178	442	325	450	478.0	575.0	0.6245
LCR 45/11	1469	2178	442	325	450	478.0	575.0	0.6245
LCR 45/12-2	1549	2258	442	325	450	483.0	580.0	0.6245
LCR 45/12	1549	2258	442	325	450	483.0	580.0	0.6245
LCR 45/13-2	1629	2338	442	325	450	488.0	585.0	0.6245

Performance Curves

Vertical multistage centrifugal pumps

LCR 45

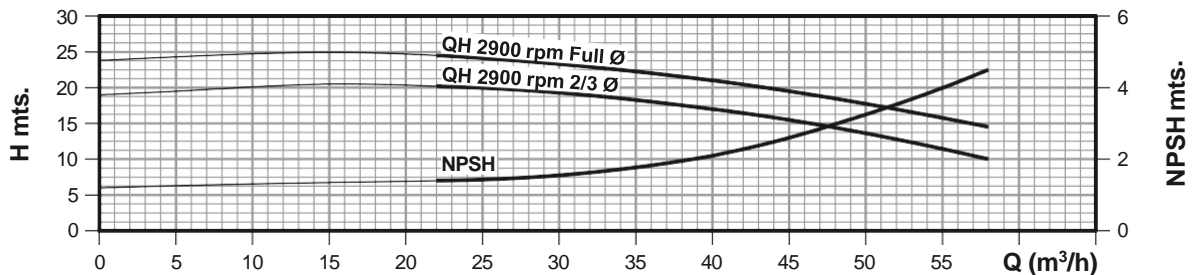
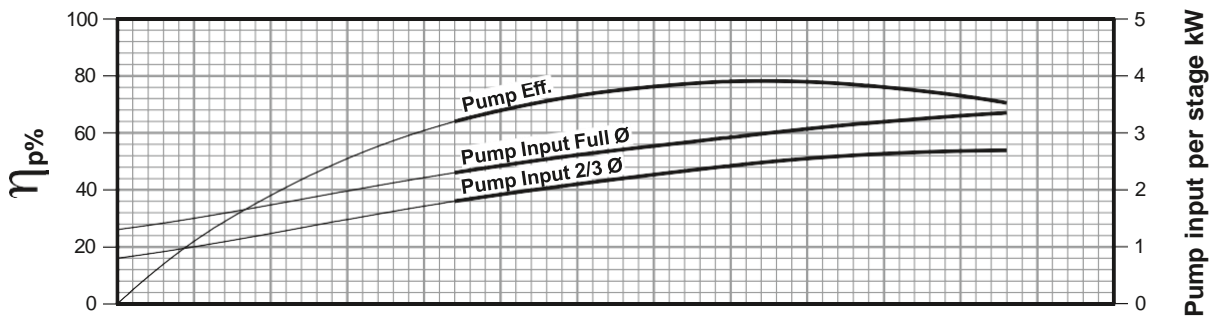
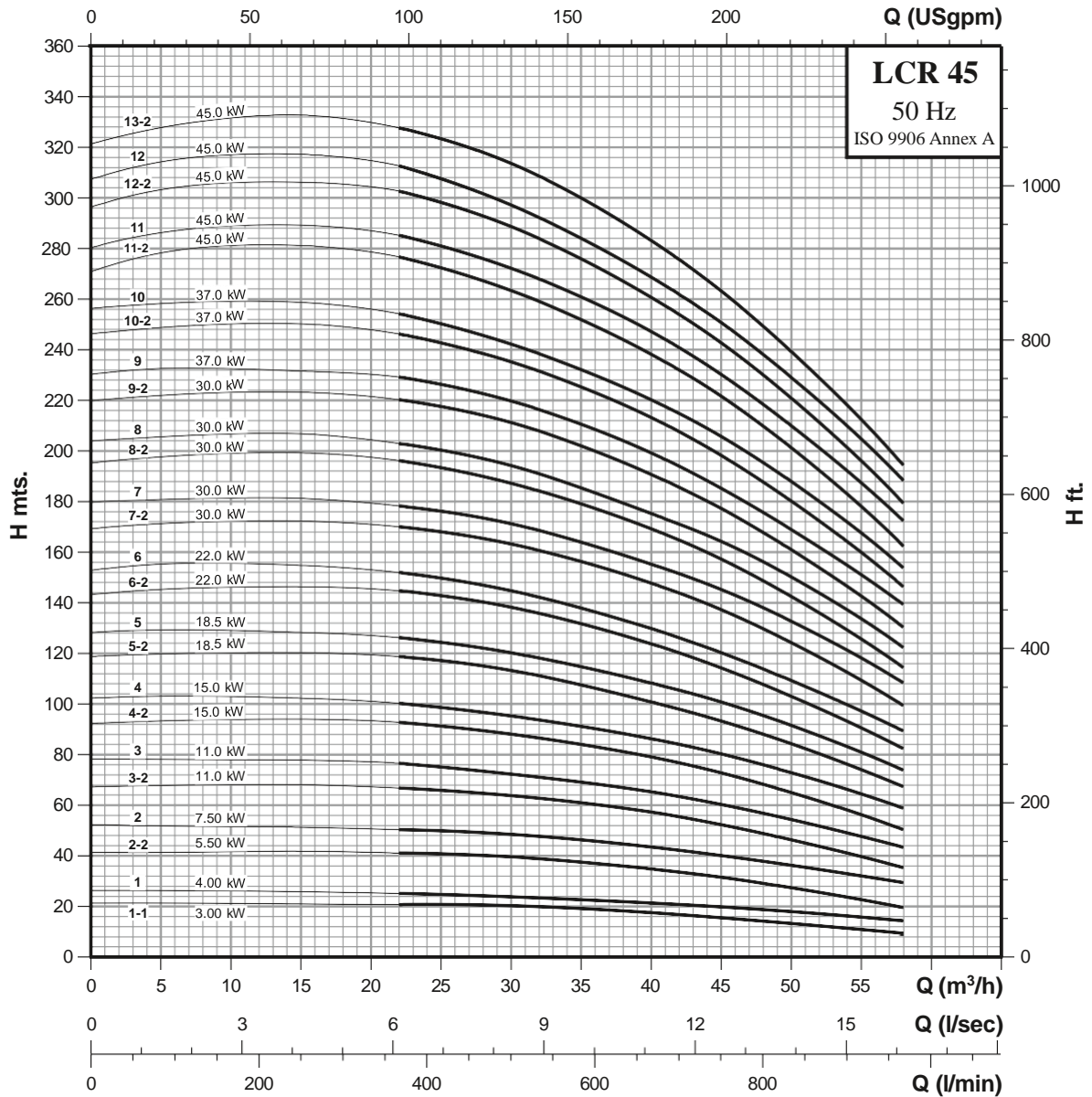

Technical Data

Vertical multistage centrifugal pumps

LCRI, LCRN 45

Performance Chart

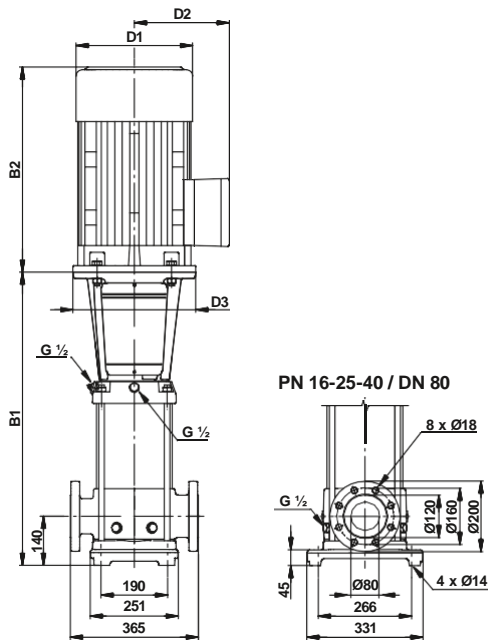

Pump Type	H.P.	kW	Q	n = 2900 rpm															
				l/min	366.7	500.0	666.7	750.0	833.3	916.7									
				m ³ /h	22.0	30.0	40.0	45.0	50.0	55.0									
			H mts.																
LCRI, LCRN 45/1-1	4.00	3.00		20	20	17	15	13	11										
LCRI, LCRN 45/1	5.50	4.00		25	24	21	20	18	16										
LCRI, LCRN 45/2-2	7.50	5.50		41	39	35	31	27	22										
LCRI, LCRN 45/2	10.0	7.50		50	48	43	40	36	32										
LCRI, LCRN 45/3-2	15.0	11.0		67	64	57	52	46	39										
LCRI, LCRN 45/3	15.0	11.0		76	72	65	60	54	48										
LCRI, LCRN 45/4-2	20.0	15.0		93	88	79	73	64	56										
LCRI, LCRN 45/4	20.0	15.0		100	95	86	80	72	64										
LCRI, LCRN 45/5-2	25.0	18.5		119	113	101	93	84	74										
LCRI, LCRN 45/5	25.0	18.5		126	120	108	101	91	80										
LCRI, LCRN 45/6-2	30.0	22.0		145	138	124	114	103	90										
LCRI, LCRN 45/6	30.0	22.0		152	145	130	120	108	97										
LCRI, LCRN 45/7-2	40.0	30.0		170	163	148	137	124	109										
LCRI, LCRN 45/7	40.0	30.0		178	171	155	145	132	117										
LCRI, LCRN 45/8-2	40.0	30.0		196	187	169	157	142	125										
LCRI, LCRN 45/8	40.0	30.0		203	194	175	164	150	133										
LCRI, LCRN 45/9-2	40.0	30.0		220	211	191	177	160	142										
LCRI, LCRN 45/9	50.0	37.0		229	220	199	185	168	150										
LCRI, LCRN 45/10-2	50.0	37.0		246	235	213	198	180	159										
LCRI, LCRN 45/10	50.0	37.0		254	242	220	206	188	167										
LCRI, LCRN 45/11-2	60.0	45.0		277	263	238	221	201	177										
LCRI, LCRN 45/11	60.0	45.0		285	272	247	230	210	187										
LCRI, LCRN 45/12-2	60.0	45.0		303	289	261	243	220	195										
LCRI, LCRN 45/12	60.0	45.0		313	297	269	251	229	204										
LCRI, LCRN 45/13-2	60.0	45.0		328	314	283	263	239	212										

Dimensions & Weights of LCRI, LCRN Pump

Pump type	Dimensions [mm]					Net weight [kg]	Gross weight [kg]	Gross volume [m ³]
	DIN flange		D1	D2	D3			
	B1	B1+B2						
LCRI, LCRN 45/1-1	559	863	194	140	-	80.0	138.0	0.3745
LCRI, LCRN 45/1	559	909	220	150	158	91.0	149.0	0.3745
LCRI, LCRN 45/2-2	639	1049	262	177	298	108.0	166.0	0.3745
LCRI, LCRN 45/2	639	1049	262	177	300	110.0	168.0	0.3745
LCRI, LCRN 45/3-2	829	1371	304	225	350	149.0	207.0	0.3745
LCRI, LCRN 45/3	829	1371	304	225	350	149.0	219.0	0.4495
LCRI, LCRN 45/4-2	909	1451	304	225	350	169.0	239.0	0.4495
LCRI, LCRN 45/4	909	1451	304	225	350	169.0	239.0	0.4495
LCRI, LCRN 45/5-2	989	1531	304	225	350	204.0	274.0	0.4495
LCRI, LCRN 45/5	989	1531	304	225	350	204.0	274.0	0.4495
LCRI, LCRN 45/6-2	1069	1679	363	262	350	240.0	310.0	0.4495
LCRI, LCRN 45/6	1069	1679	363	262	350	240.0	310.0	0.4495
LCRI, LCRN 45/7-2	1149	1795	415	300	400	321.0	404.0	0.5370
LCRI, LCRN 45/7	1149	1795	415	300	400	321.0	404.0	0.5370
LCRI, LCRN 45/8-2	1229	1875	415	300	400	336.0	419.0	0.5370
LCRI, LCRN 45/8	1229	1875	415	300	400	336.0	419.0	0.5370
LCRI, LCRN 45/9-2	1309	1955	415	300	400	341.0	424.0	0.5370
LCRI, LCRN 45/9	1309	2012	415	300	400	361.0	444.0	0.5370
LCRI, LCRN 45/10-2	1389	2092	415	300	400	366.0	463.0	0.6245
LCRI, LCRN 45/10	1389	2092	415	300	400	366.0	463.0	0.6245
LCRI, LCRN 45/11-2	1469	2178	442	325	450	478.0	575.0	0.6245
LCRI, LCRN 45/11	1469	2178	442	325	450	478.0	575.0	0.6245
LCRI, LCRN 45/12-2	1549	2258	442	325	450	483.0	580.0	0.6245
LCRI, LCRN 45/12	1549	2258	442	325	450	483.0	580.0	0.6245
LCRI, LCRN 45/13-2	1629	2338	442	325	450	488.0	585.0	0.6245

Performance Curves

Vertical multistage centrifugal pumps

LCRI, LCRN 45

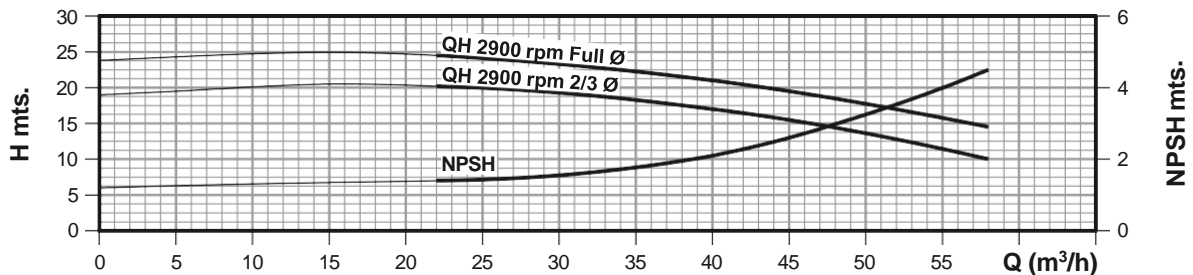
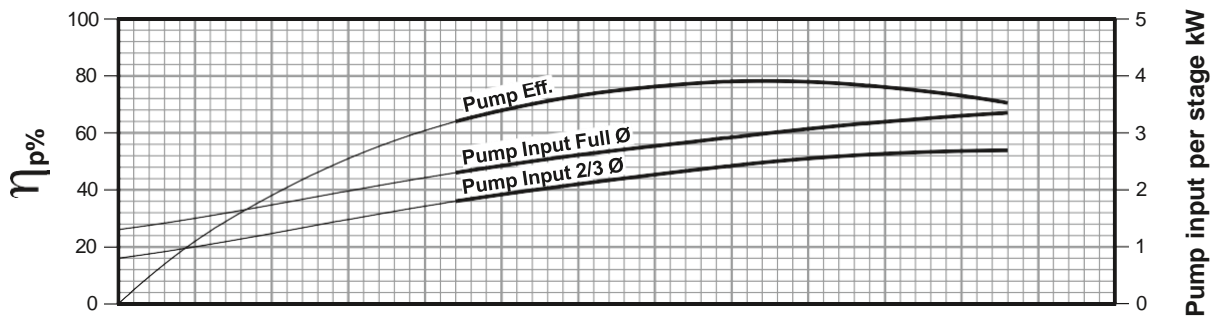
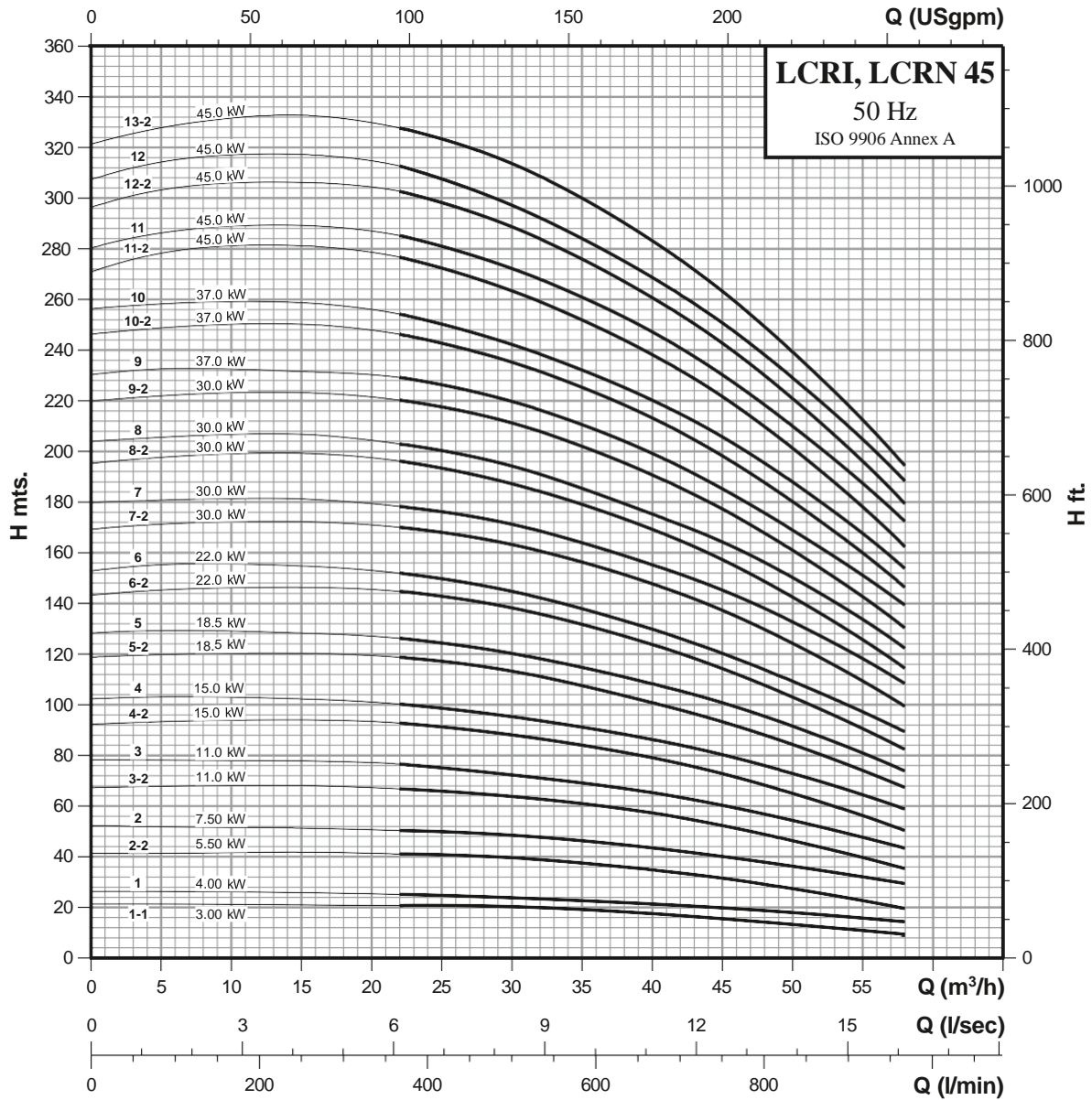

Technical Data

Vertical multistage centrifugal pumps

LCR 64

Performance Chart

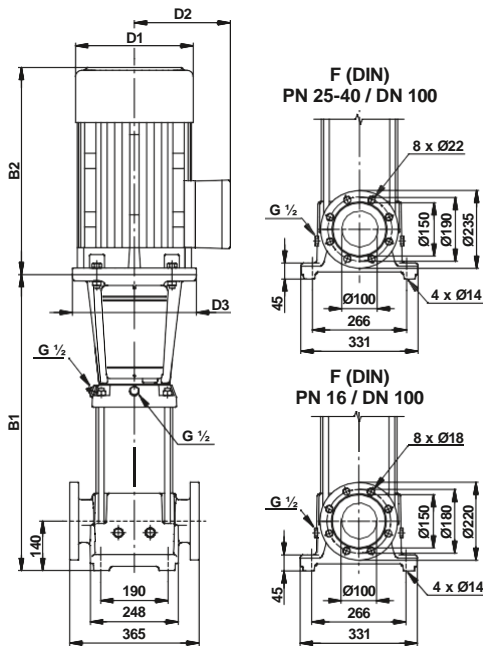

Pump Type	H.P.	kW	Q l/min m ³ /h	n = 2900 rpm					
				666.7	833.3	1000.0	1083.4	1166.7	1333.4
				40.0	50.0	60.0	65.0	70.0	80.0
LCR 64/1-1	5.50	4.00	H mts.	19	17	14	13	12	8
LCR 64/1	7.50	5.50		27	25	22	21	20	17
LCR 64/2-2	10.0	7.50		38	36	32	30	26	20
LCR 64/2-1	15.0	11.0		46	43	39	37	36	29
LCR 64/2	15.0	11.0		53	50	46	44	42	37
LCR 64/3-2	20.0	15.0		65	61	56	53	50	41
LCR 64/3-1	20.0	15.0		72	68	62	59	56	47
LCR 64/3	25.0	18.5		81	76	71	68	65	57
LCR 64/4-2	25.0	18.5		92	87	79	75	70	60
LCR 64/4-1	30.0	22.0		100	95	87	82	77	66
LCR 64/4	30.0	22.0		108	102	94	90	85	75
LCR 64/5-2	40.0	30.0		122	115	105	100	94	81
LCR 64/5-1	40.0	30.0		130	123	113	108	102	88
LCR 64/5	40.0	30.0		137	130	120	115	109	96
LCR 64/6-2	40.0	30.0		148	140	129	123	116	99
LCR 64/6-1	50.0	37.0		156	149	137	131	124	108
LCR 64/6	50.0	37.0		164	156	144	138	131	116
LCR 64/7-2	50.0	37.0		176	167	154	146	138	120
LCR 64/7-1	50.0	37.0		183	174	161	154	145	128
LCR 64/7	60.0	45.0		194	185	172	165	157	138
LCR 64/8-2	60.0	45.0	206	195	181	173	163	141	
LCR 64/8-1	60.0	45.0	214	203	188	180	170	148	

Dimensions & Weights of LCR Pump

Pump type	Dimensions [mm]					Net weight [kg]	Gross weight [kg]	Gross volume [m ³]
	DIN flange		D1	D2	D3			
	B1	B1+B2						
LCR 64/1-1	561	911	220	150	158	91.0	149.0	0.3745
LCR 64/1	561	971	262	177	298	102.0	160.0	0.3745
LCR 64/2-2	644	1054	262	177	298	114.0	172.0	0.3745
LCR 64/2-1	754	1296	304	225	350	149.0	207.0	0.3745
LCR 64/2	754	1296	304	225	350	149.0	207.0	0.3745
LCR 64/3-2	836	1378	304	225	350	174.0	232.0	0.3745
LCR 64/3-1	836	1378	304	225	350	174.0	232.0	0.3745
LCR 64/3	836	1378	304	225	350	204.0	262.0	0.3745
LCR 64/4-2	919	1461	304	225	350	214.0	284.0	0.4495
LCR 64/4-1	919	1529	363	262	350	245.0	315.0	0.4495
LCR 64/4	919	1529	363	262	350	245.0	315.0	0.4495
LCR 64/5-2	1001	1647	415	300	400	316.0	386.0	0.4495
LCR 64/5-1	1001	1647	415	300	400	316.0	386.0	0.4495
LCR 64/5	1001	1647	415	300	400	316.0	386.0	0.4495
LCR 64/6-2	1084	1730	415	300	400	336.0	419.0	0.5370
LCR 64/6-1	1084	1787	415	300	400	356.0	439.0	0.5370
LCR 64/6	1084	1787	415	300	400	356.0	439.0	0.5370
LCR 64/7-2	1166	1869	415	300	400	376.0	459.0	0.5370
LCR 64/7-1	1166	1869	415	300	400	376.0	459.0	0.5370
LCR 64/7	1166	1875	442	325	450	440.0	523.0	0.5370
LCR 64/8-2	1249	1958	442	325	450	473.0	556.0	0.5370
LCR 64/8-1	1249	1958	442	325	450	473.0	556.0	0.5370

Performance Curves

Vertical multistage centrifugal pumps

LCR 64

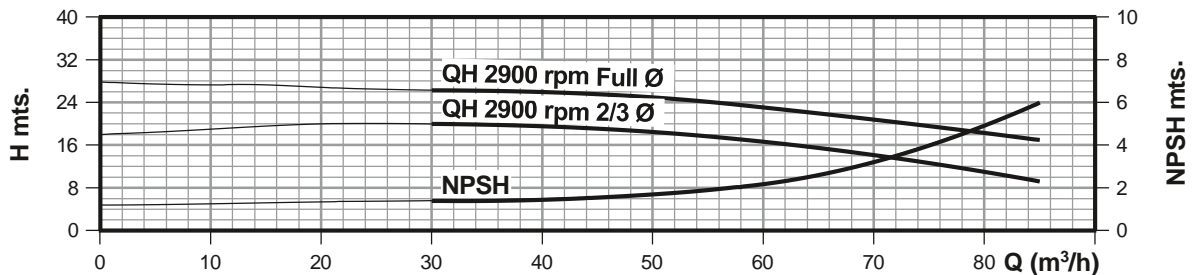
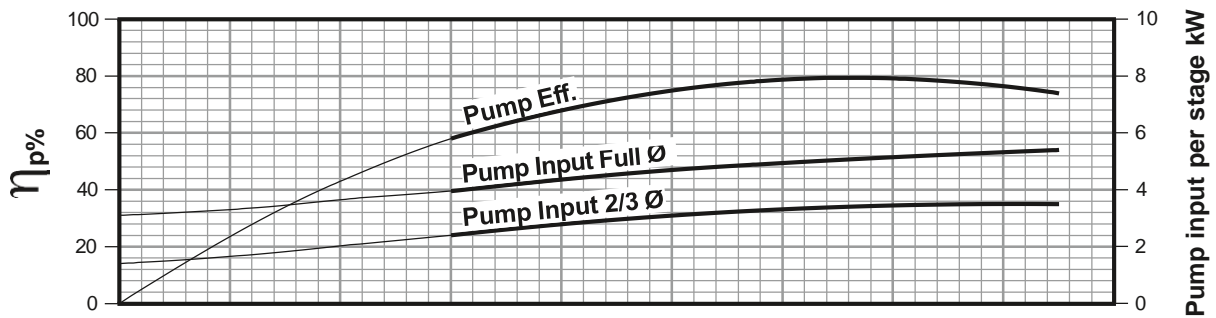
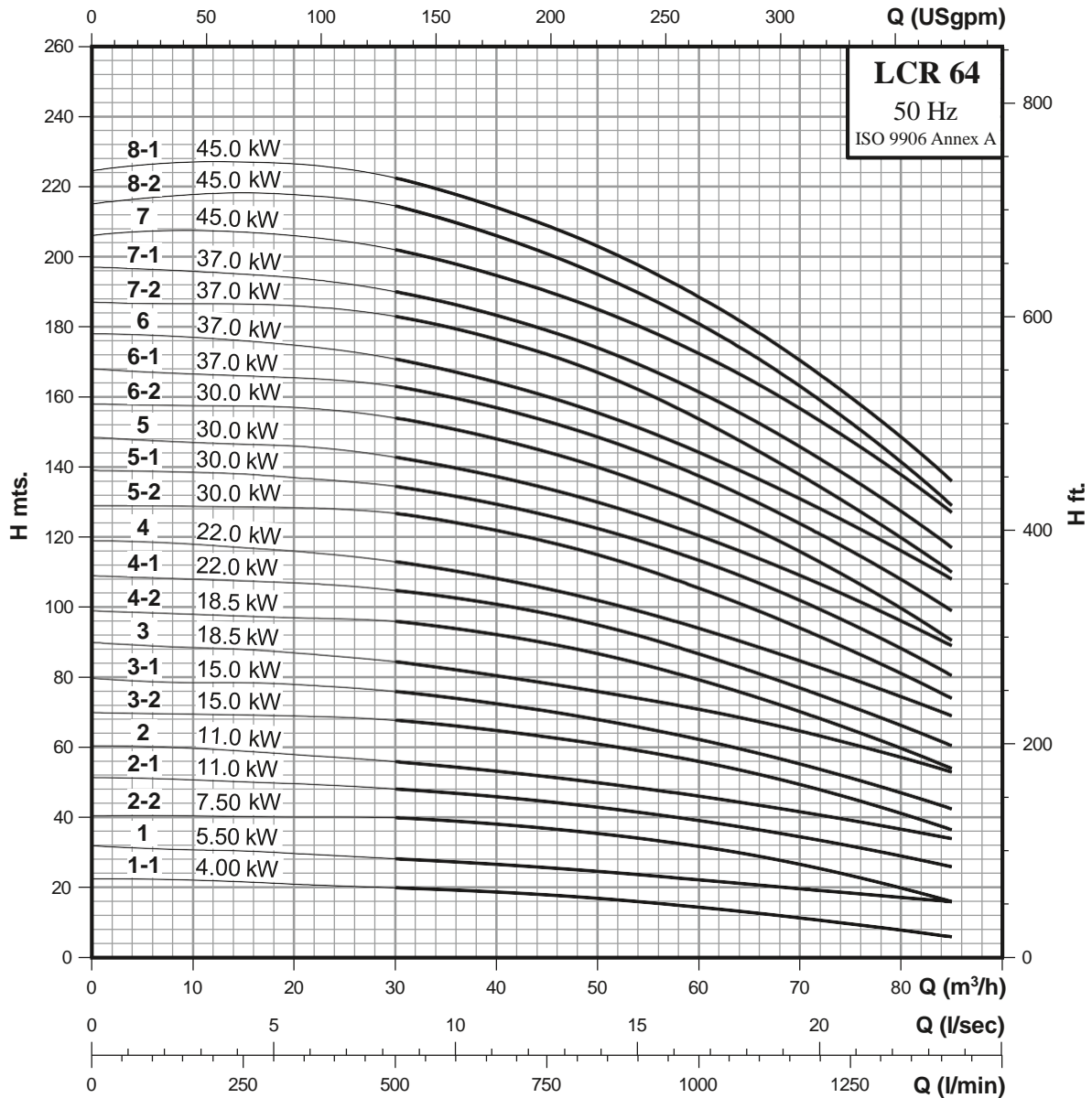

Technical Data

Vertical multistage centrifugal pumps

LCRI, LCRN 64

Performance Chart

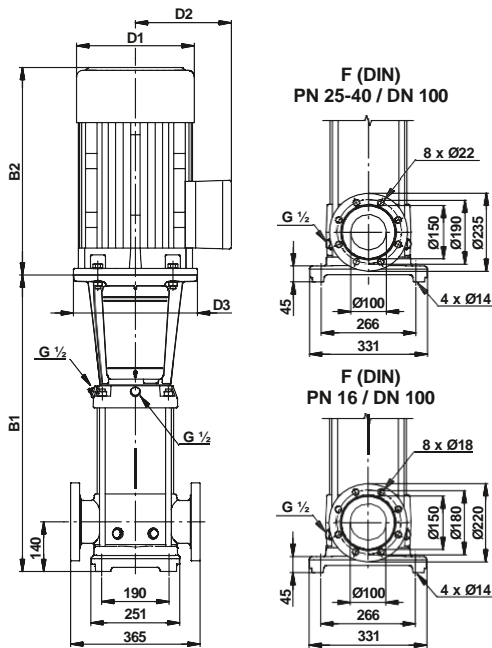

Pump Type	H.P.	kW	Q l/min m ³ /h	n = 2900 rpm					
				666.7	833.3	1000.0	1083.4	1166.7	1333.4
				40.0	50.0	60.0	65.0	70.0	80.0
LCRI, LCRN 64/1-1	5.50	4.00	H mts.	19	17	14	13	12	8
LCRI, LCRN 64/1	7.50	5.50		27	25	22	21	20	17
LCRI, LCRN 64/2-2	10.0	7.50		38	36	32	30	26	20
LCRI, LCRN 64/2-1	15.0	11.0		46	43	39	37	36	29
LCRI, LCRN 64/2	15.0	11.0		53	50	46	44	42	37
LCRI, LCRN 64/3-2	20.0	15.0		65	61	56	53	50	41
LCRI, LCRN 64/3-1	20.0	15.0		72	68	62	59	56	47
LCRI, LCRN 64/3	25.0	18.5		81	76	71	68	65	57
LCRI, LCRN 64/4-2	25.0	18.5		92	87	79	75	70	60
LCRI, LCRN 64/4-1	30.0	22.0		100	95	87	82	77	66
LCRI, LCRN 64/4	30.0	22.0		108	102	94	90	85	75
LCRI, LCRN 64/5-2	40.0	30.0		122	115	105	100	94	81
LCRI, LCRN 64/5-1	40.0	30.0		130	123	113	108	102	88
LCRI, LCRN 64/5	40.0	30.0		137	130	120	115	109	96
LCRI, LCRN 64/6-2	40.0	30.0		148	140	129	123	116	99
LCRI, LCRN 64/6-1	50.0	37.0		156	149	137	131	124	108
LCRI, LCRN 64/6	50.0	37.0		164	156	144	138	131	116
LCRI, LCRN 64/7-2	50.0	37.0		176	167	154	146	138	120
LCRI, LCRN 64/7-1	50.0	37.0		183	174	161	154	145	128
LCRI, LCRN 64/7	60.0	45.0		194	185	172	165	157	138
LCRI, LCRN 64/8-2	60.0	45.0	206	195	181	173	163	141	
LCRI, LCRN 64/8-1	60.0	45.0	214	203	188	180	170	148	

Dimensions & Weights of LCRI, LCRN Pump

Pump type	Dimensions [mm]					Net weight [kg]	Gross weight [kg]	Gross volume [m ³]
	DIN flange		D1	D2	D3			
	B1	B1+B2						
LCRI, LCRN 64/1-1	561	911	220	150	158	91.0	149.0	0.3745
LCRI, LCRN 64/1	561	971	262	177	298	102.0	160.0	0.3745
LCRI, LCRN 64/2-2	644	1054	262	177	298	114.0	172.0	0.3745
LCRI, LCRN 64/2-1	754	1296	304	225	350	149.0	207.0	0.3745
LCRI, LCRN 64/2	754	1296	304	225	350	149.0	207.0	0.3745
LCRI, LCRN 64/3-2	836	1378	304	225	350	174.0	232.0	0.3745
LCRI, LCRN 64/3-1	836	1378	304	225	350	174.0	232.0	0.3745
LCRI, LCRN 64/3	836	1378	304	225	350	204.0	262.0	0.3745
LCRI, LCRN 64/4-2	919	1461	304	225	350	214.0	284.0	0.4495
LCRI, LCRN 64/4-1	919	1529	363	262	350	245.0	315.0	0.4495
LCRI, LCRN 64/4	919	1529	363	262	350	245.0	315.0	0.4495
LCRI, LCRN 64/5-2	1001	1647	415	300	400	316.0	386.0	0.4495
LCRI, LCRN 64/5-1	1001	1647	415	300	400	316.0	386.0	0.4495
LCRI, LCRN 64/5	1001	1647	415	300	400	316.0	386.0	0.4495
LCRI, LCRN 64/6-2	1084	1730	415	300	400	336.0	419.0	0.5370
LCRI, LCRN 64/6-1	1084	1787	415	300	400	356.0	439.0	0.5370
LCRI, LCRN 64/6	1084	1787	415	300	400	356.0	439.0	0.5370
LCRI, LCRN 64/7-2	1166	1869	415	300	400	376.0	459.0	0.5370
LCRI, LCRN 64/7-1	1166	1869	415	300	400	376.0	459.0	0.5370
LCRI, LCRN 64/7	1166	1875	442	325	450	440.0	523.0	0.5370
LCRI, LCRN 64/8-2	1249	1958	442	325	450	473.0	556.0	0.5370
LCRI, LCRN 64/8-1	1249	1958	442	325	450	473.0	556.0	0.5370

Performance Curves

Vertical multistage centrifugal pumps

LCRI, LCRN 64

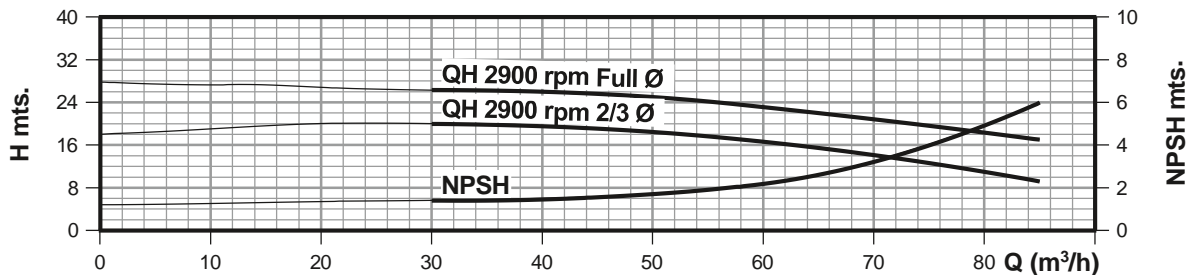
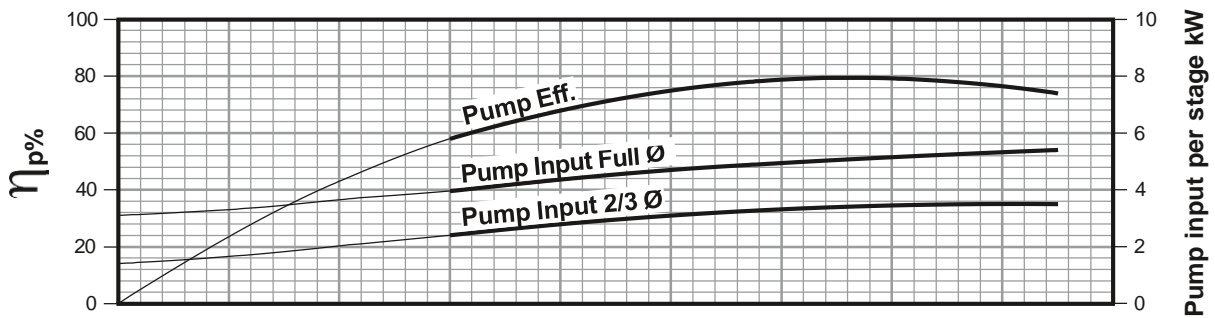
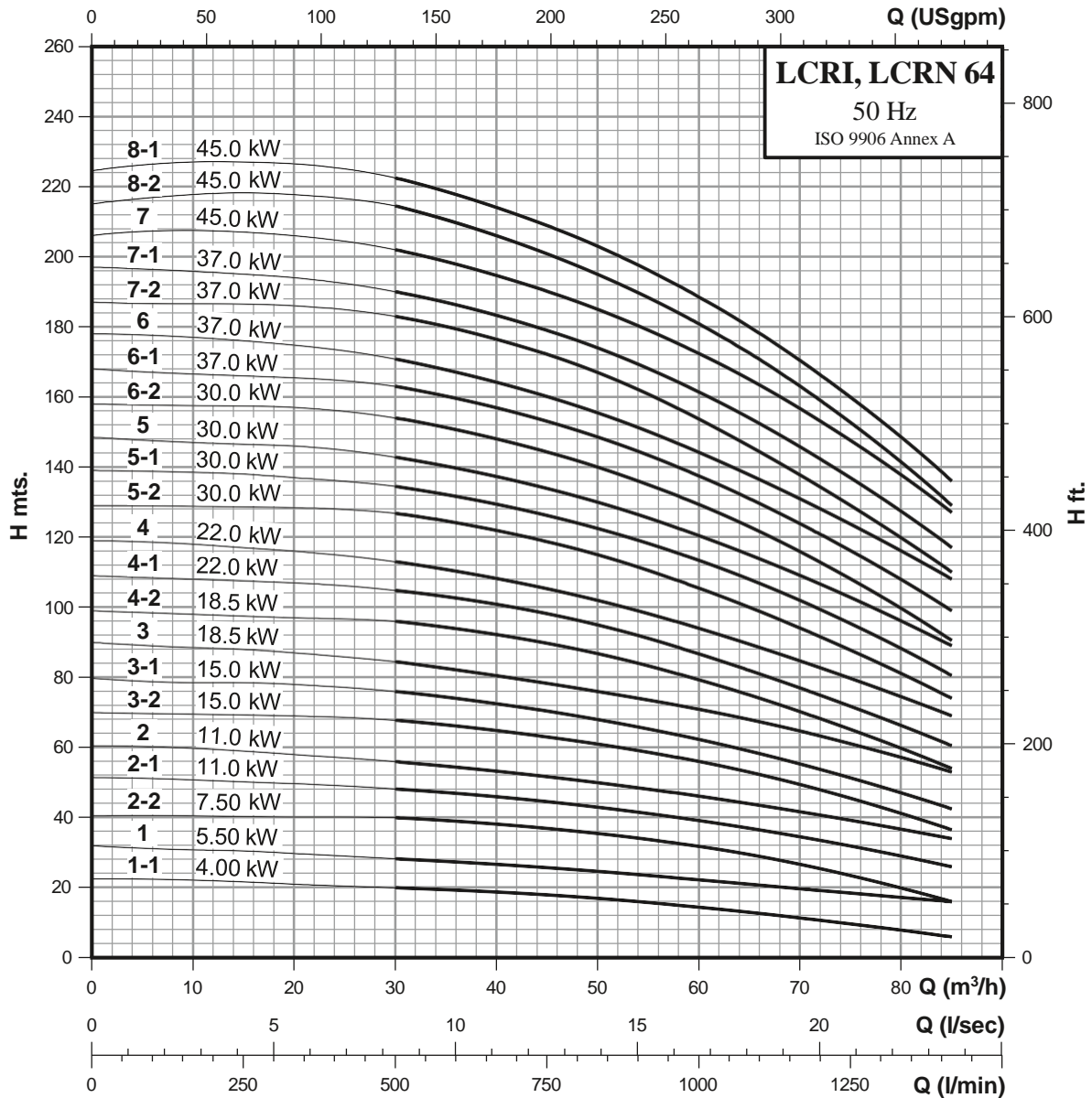

Technical Data

Vertical multistage centrifugal pumps

LCR 90

Performance Chart

Pump Type	H.P.	kW	Q l/min m ³ /h	n = 2900 rpm					
				1000.0	1250.0	1416.7	1500.0	1666.7	1833.4
				60.0	75.0	85.0	90.0	100.0	110.0
LCR 90/1-1	7.50	5.50	H mts.	20	17	15	14	11	7
LCR 90/1	10.0	7.50		25	23	22	20	18	14
LCR 90/2-2	15.0	11.0		42	37	34	31	24	17
LCR 90/2	20.0	15.0		53	48	45	43	37	32
LCR 90/3-2	25.0	18.5		68	61	55	52	44	35
LCR 90/3	30.0	22.0		80	73	68	65	59	50
LCR 90/4-2	40.0	30.0		97	88	81	77	67	55
LCR 90/4	40.0	30.0		109	99	93	89	81	69
LCR 90/5-2	50.0	37.0		125	112	104	98	87	72
LCR 90/5	50.0	37.0		137	125	116	111	100	87
LCR 90/6-2	60.0	45.0		154	140	130	123	109	92
LCR 90/6	60.0	45.0		166	152	142	136	123	108

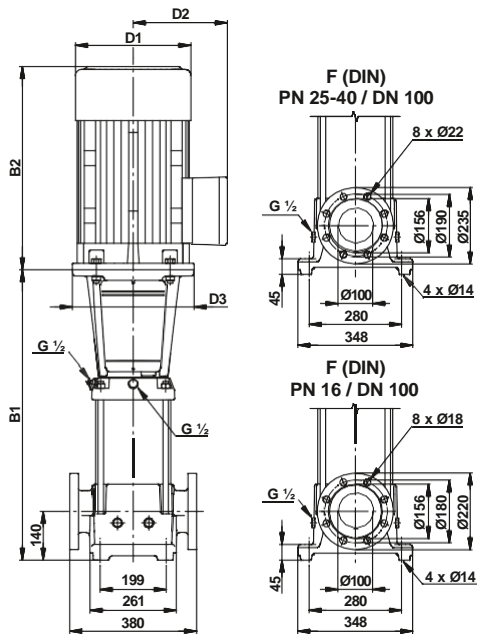

Dimensions & Weights of LCR Pump

Pump type	Dimensions [mm]					Net weight [kg]	Gross weight [kg]	Gross volume [m ³]
	DIN flange		D1	D2	D3			
	B1	B1+B2						
LCR 90/1-1	571	981	262	177	298	107.0	165.0	0.3745
LCR 90/1	571	981	262	177	298	109.0	167.0	0.3745
LCR 90/2-2	773	1315	304	225	350	150.0	208.0	0.3745
LCR 90/2	773	1315	304	225	350	164.0	222.0	0.3745
LCR 90/3-2	865	1407	304	225	350	214.0	284.0	0.4495
LCR 90/3	865	1475	363	262	350	245.0	315.0	0.4495
LCR 90/4-2	957	1603	415	300	400	326.0	396.0	0.4495
LCR 90/4	957	1603	415	300	400	326.0	396.0	0.4495
LCR 90/5-2	1049	1752	415	300	400	366.0	449.0	0.5370
LCR 90/5	1049	1752	415	300	400	366.0	449.0	0.5370
LCR 90/6-2	1141	1850	442	325	450	437.0	520.0	0.5370
LCR 90/6	1141	1850	442	325	450	437.0	520.0	0.5370

Performance Curves

Vertical multistage centrifugal pumps

LCR 90

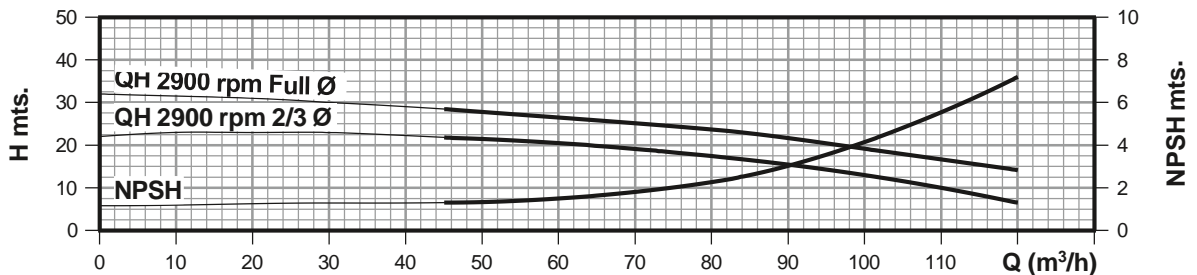
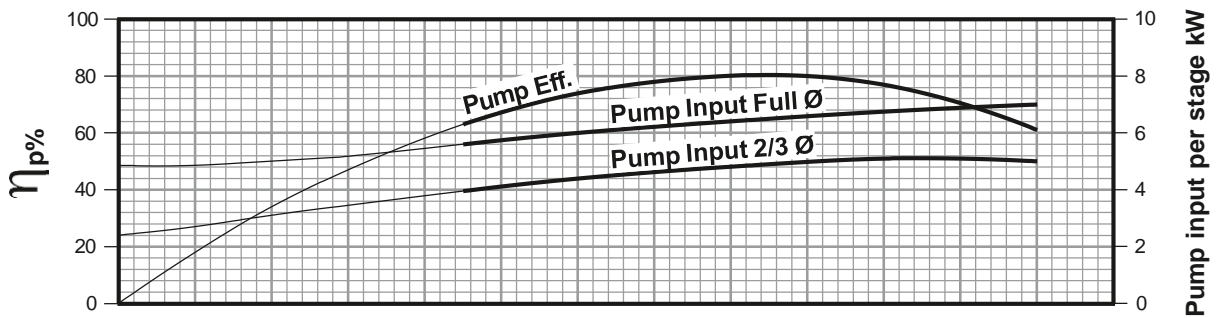
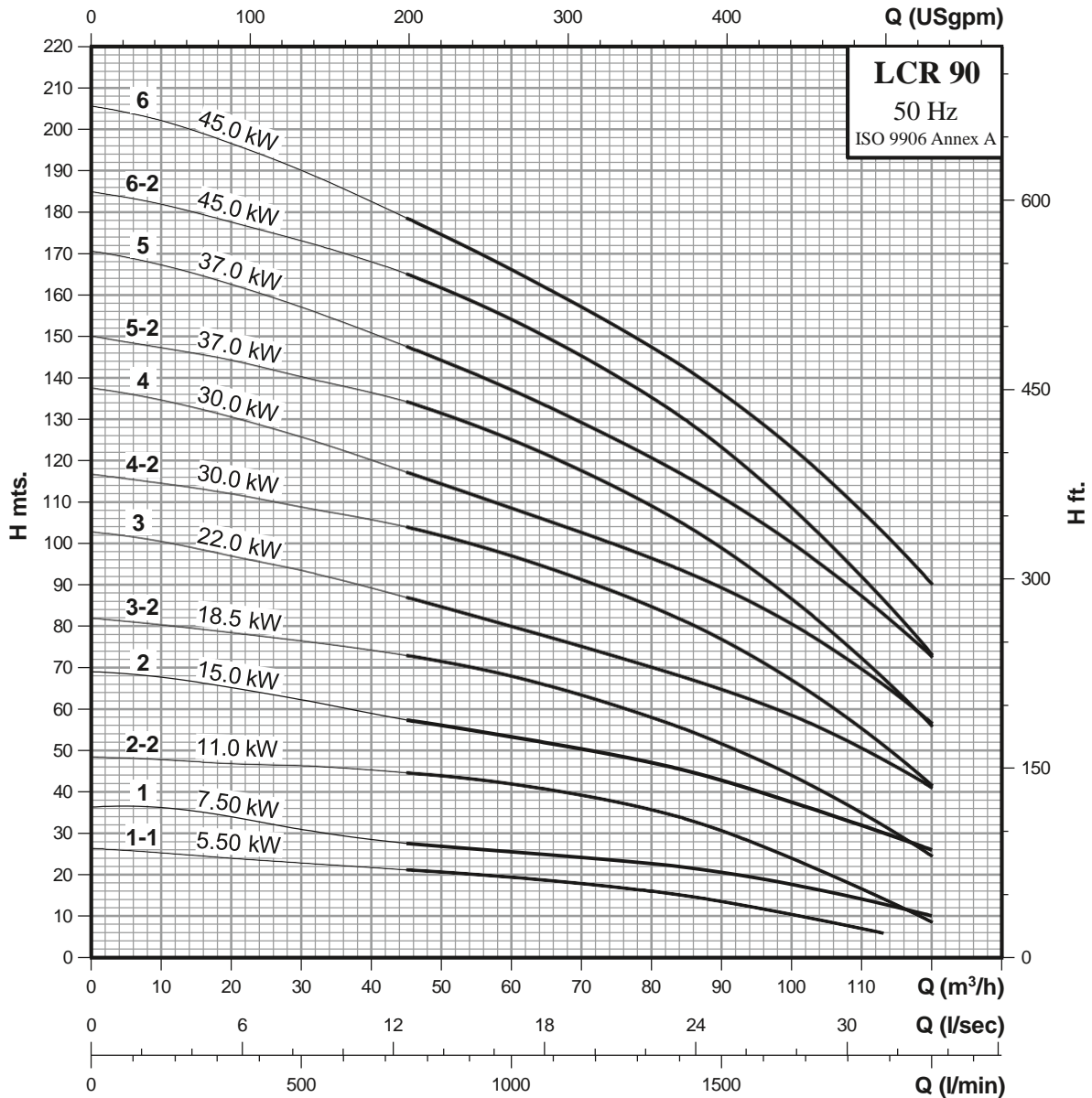

Technical Data

Vertical multistage centrifugal pumps

LCRI, LCRN 90

Performance Chart

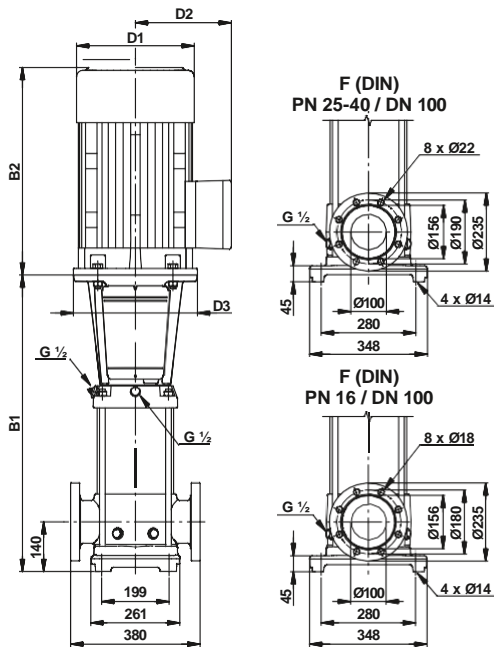

Pump Type	H.P.	kW	Q l/min m ³ /h	n = 2900 rpm					
				1000.0	1250.0	1416.7	1500.0	1666.7	1833.4
				60.0	75.0	85.0	90.0	100.0	110.0
LCRI, LCRN 90/1-1	7.50	5.50	H mts.	20	17	15	14	11	7
LCRI, LCRN 90/1	10.0	7.50		25	23	22	20	18	14
LCRI, LCRN 90/2-2	15.0	11.0		42	37	34	31	24	17
LCRI, LCRN 90/2	20.0	15.0		53	48	45	43	37	32
LCRI, LCRN 90/3-2	25.0	18.5		68	61	55	52	44	35
LCRI, LCRN 90/3	30.0	22.0		80	73	68	65	59	50
LCRI, LCRN 90/4-2	40.0	30.0		97	88	81	77	67	55
LCRI, LCRN 90/4	40.0	30.0		109	99	93	89	81	69
LCRI, LCRN 90/5-2	50.0	37.0		125	112	104	98	87	72
LCRI, LCRN 90/5	50.0	37.0		137	125	116	111	100	87
LCRI, LCRN 90/6-2	60.0	45.0		154	140	130	123	109	92
LCRI, LCRN 90/6	60.0	45.0		166	152	142	136	123	108

Dimensions & Weights of LCRI, LCRN Pump

Pump type	Dimensions [mm]					Net weight [kg]	Gross weight [kg]	Gross volume [m ³]
	DIN flange		D1	D2	D3			
	B1	B1+B2						
LCRI, LCRN 90/1-1	571	981	262	177	298	107.0	165.0	0.3745
LCRI, LCRN 90/1	571	981	262	177	298	109.0	167.0	0.3745
LCRI, LCRN 90/2-2	773	1315	304	225	350	150.0	208.0	0.3745
LCRI, LCRN 90/2	773	1315	304	225	350	164.0	222.0	0.3745
LCRI, LCRN 90/3-2	865	1407	304	225	350	214.0	284.0	0.4495
LCRI, LCRN 90/3	865	1475	363	262	350	245.0	315.0	0.4495
LCRI, LCRN 90/4-2	957	1603	415	300	400	326.0	396.0	0.4495
LCRI, LCRN 90/4	957	1603	415	300	400	326.0	396.0	0.4495
LCRI, LCRN 90/5-2	1049	1752	415	300	400	366.0	449.0	0.5370
LCRI, LCRN 90/5	1049	1752	415	300	400	366.0	449.0	0.5370
LCRI, LCRN 90/6-2	1141	1850	442	325	450	437.0	520.0	0.5370
LCRI, LCRN 90/6	1141	1850	442	325	450	437.0	520.0	0.5370

Performance Curves

Vertical multistage centrifugal pumps

LCRI, LCRN 90

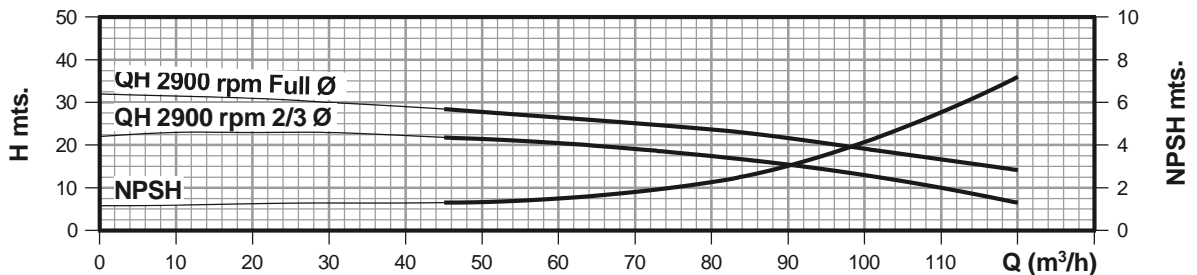
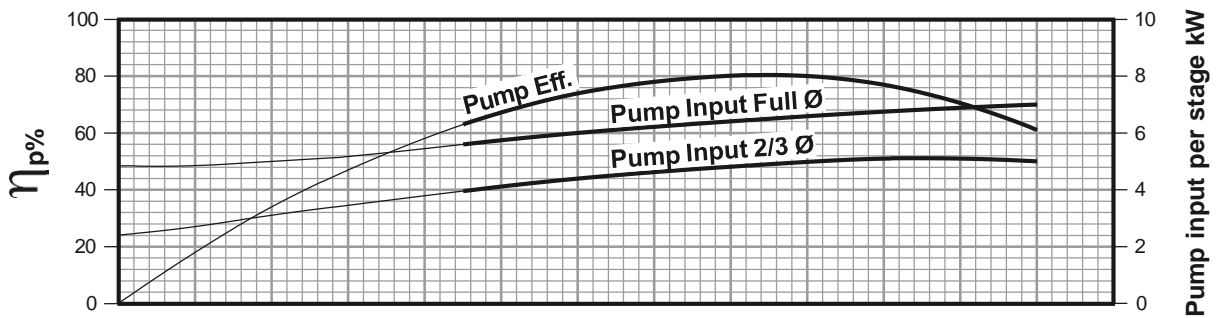
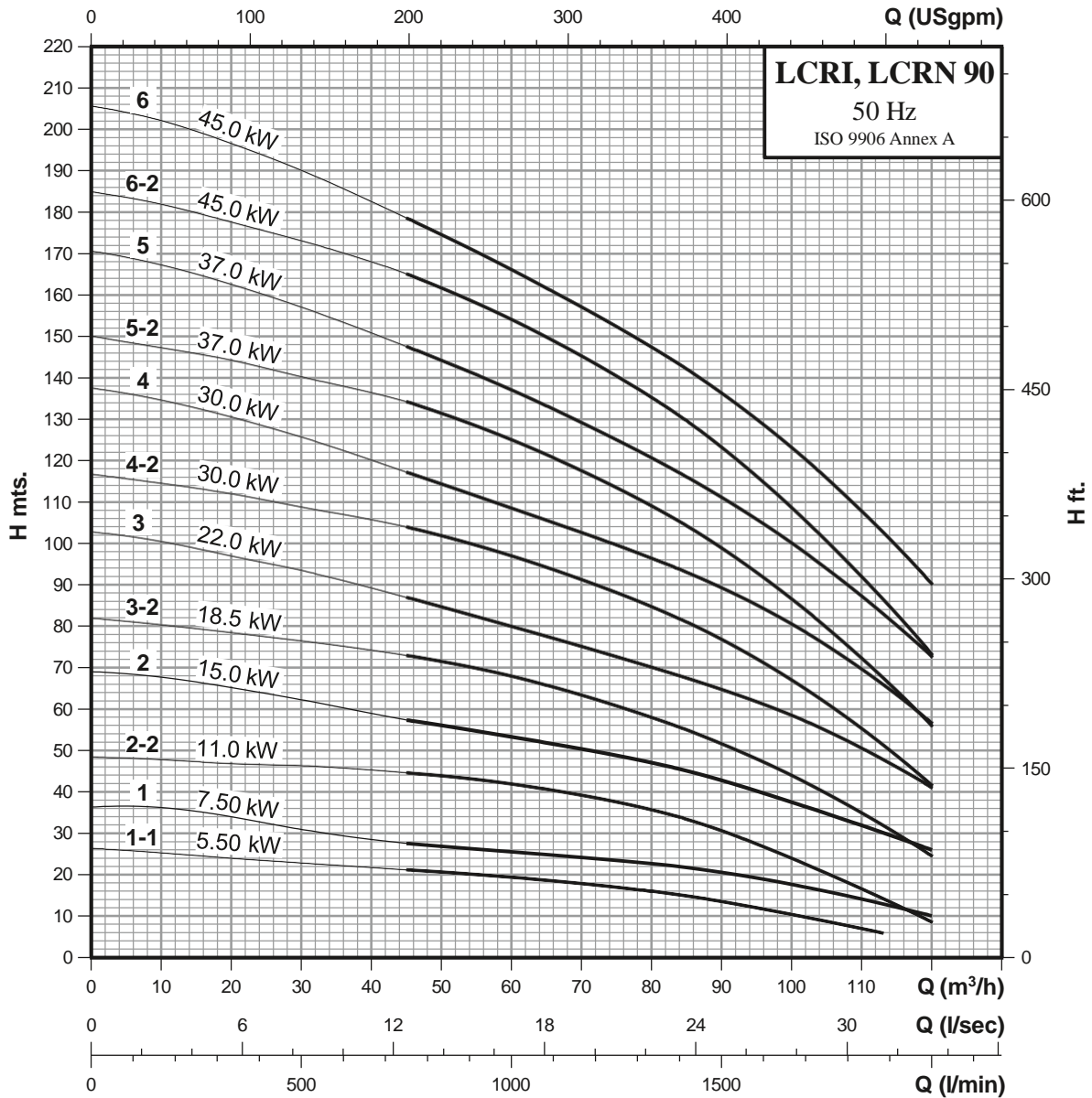

Technical Data

Vertical multistage centrifugal pumps

LCR 120

Performance Chart

Pump Type	H.P.	kW	Q l/min m ³ /h	n = 2900 rpm					
				1333.4	1666.7	2000.0	2166.7	2333.4	2666.7
				80.0	100.0	120.0	130.0	140.0	160.0
LCR 120/1	15.0	11.0	H	24	22	19	17	15	10
LCR 120/2-1	25.0	18.5	mts.	44	40	35	32	28	19
LCR 120/2	30.0	22.0		53	48	42	39	35	26
LCR 120/3	40.0	30.0		78	72	64	59	55	42
LCR 120/4-1	50.0	37.0		101	93	83	77	71	53
LCR 120/5-1	60.0	45.0		124	114	103	96	88	68
LCR 120/6-1	75.0	55.0		156	146	133	125	116	92
LCR 120/7	100.0	75.0		190	177	162	153	143	113

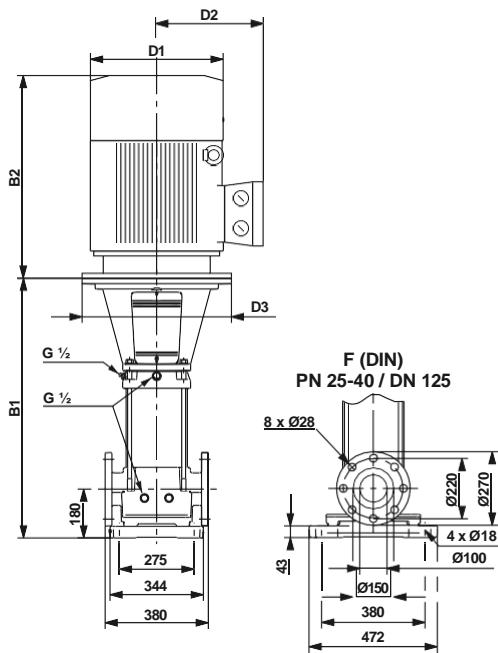

Dimensions & Weights of LCR Pump

Pump type	Dimensions [mm]					Net weight [kg]	Gross weight [kg]	Gross volume [m ³]
	DIN flange		D1	D2	D3			
	B1	B1+B2						
LCR 120/1	834	1376	304	225	350	191.0	291.0	0.2787
LCR 120/2-1	990	1532	304	225	350	227.0	327.0	0.2787
LCR 120/2	990	1600	363	262	350	240.0	360.0	0.5872
LCR 120/3	1145	1791	415	300	400	368.0	488.0	0.5872
LCR 120/4-1	1301	2004	415	300	400	392.0	512.0	0.5872
LCR 120/5-1	1456	2165	442	325	450	487.0	627.0	1.3716
LCR 120/6-1	1642	2440	493	414	550	627.0	767.0	1.3716
LCR 120/7	1797	2682	548	445	550	741.0	881.0	1.3716

Performance Curves

Vertical multistage centrifugal pumps

LCR 120

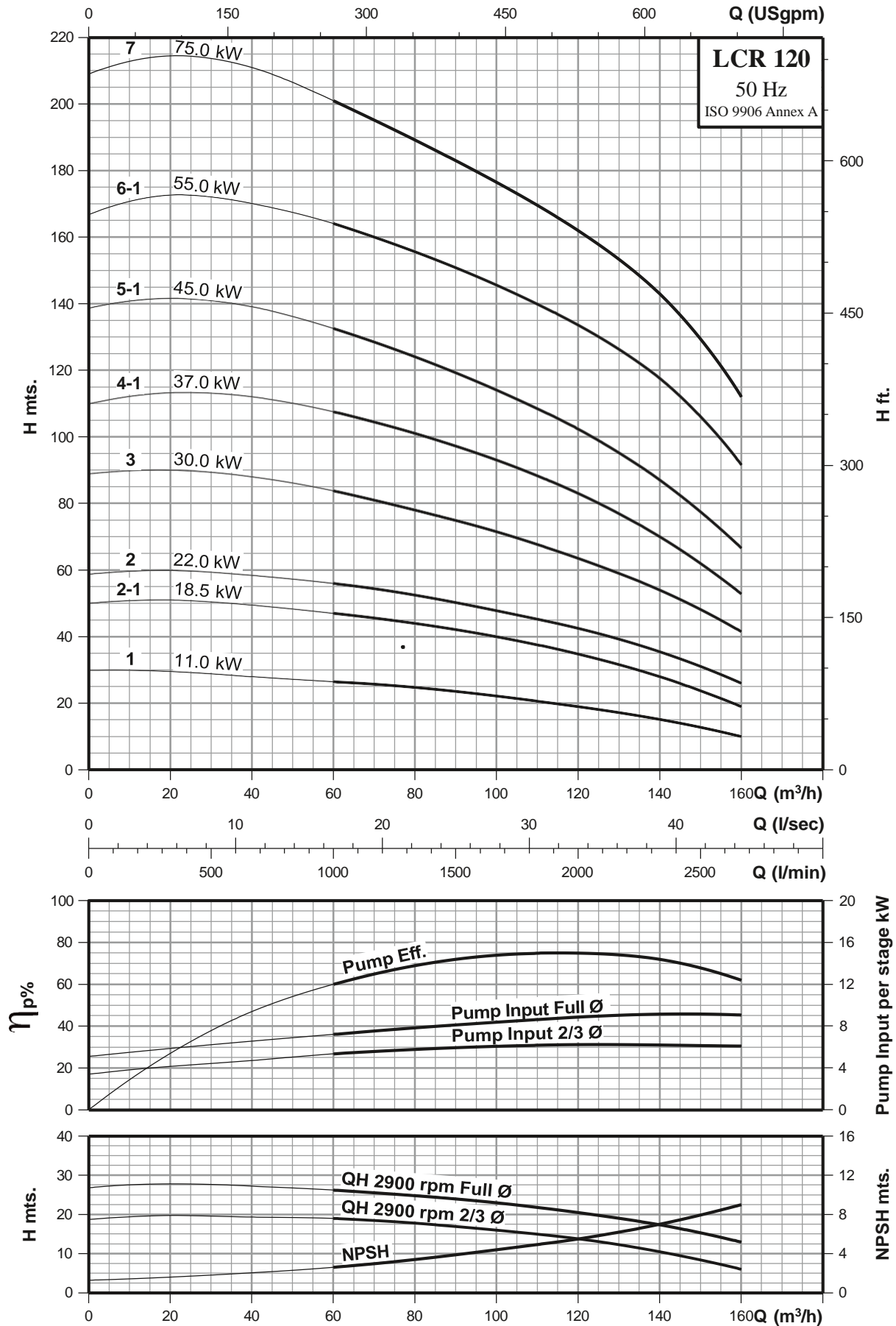

Technical Data

Vertical multistage centrifugal pumps

LCRN 120

Performance Chart

Pump Type	H.P.	kW	Q l/min m ³ /h	n = 2900 rpm					
				1333.4	1666.7	2000.0	2166.7	2333.4	2666.7
				80.0	100.0	120.0	130.0	140.0	160.0
LCRN 120/1	15.0	11.0	H	24	22	19	17	15	10
LCRN 120/2-1	25.0	18.5	mts.	44	40	35	32	28	19
LCRN 120/2	30.0	22.0		53	48	42	39	35	26
LCRN 120/3	40.0	30.0		78	72	64	59	55	42
LCRN 120/4-1	50.0	37.0		101	93	83	77	71	53
LCRN 120/5-1	60.0	45.0		124	114	103	96	88	68
LCRN 120/6-1	75.0	55.0		156	146	133	125	116	92
LCRN 120/7	100.0	75.0		190	177	162	153	143	113

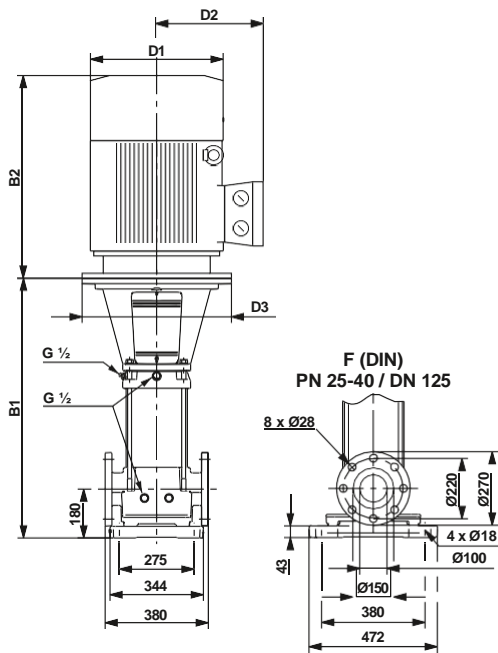

Dimensions & Weights of LCRN Pump

Pump type	Dimensions [mm]					Net weight [kg]	Gross weight [kg]	Gross volume [m ³]
	DIN flange		D1	D2	D3			
	B1	B1+B2						
LCRN 120/1	834	1376	304	225	350	191.0	291.0	0.2787
LCRN 120/2-1	990	1532	304	225	350	227.0	327.0	0.2787
LCRN 120/2	990	1600	363	262	350	240.0	360.0	0.5872
LCRN 120/3	1145	1791	415	300	400	368.0	488.0	0.5872
LCRN 120/4-1	1301	2004	415	300	400	392.0	512.0	0.5872
LCRN 120/5-1	1456	2165	442	325	450	487.0	627.0	1.3716
LCRN 120/6-1	1642	2440	493	414	550	627.0	767.0	1.3716
LCRN 120/7	1797	2682	548	445	550	741.0	881.0	1.3716

Performance Curves

Vertical multistage centrifugal pumps

LCRN 120

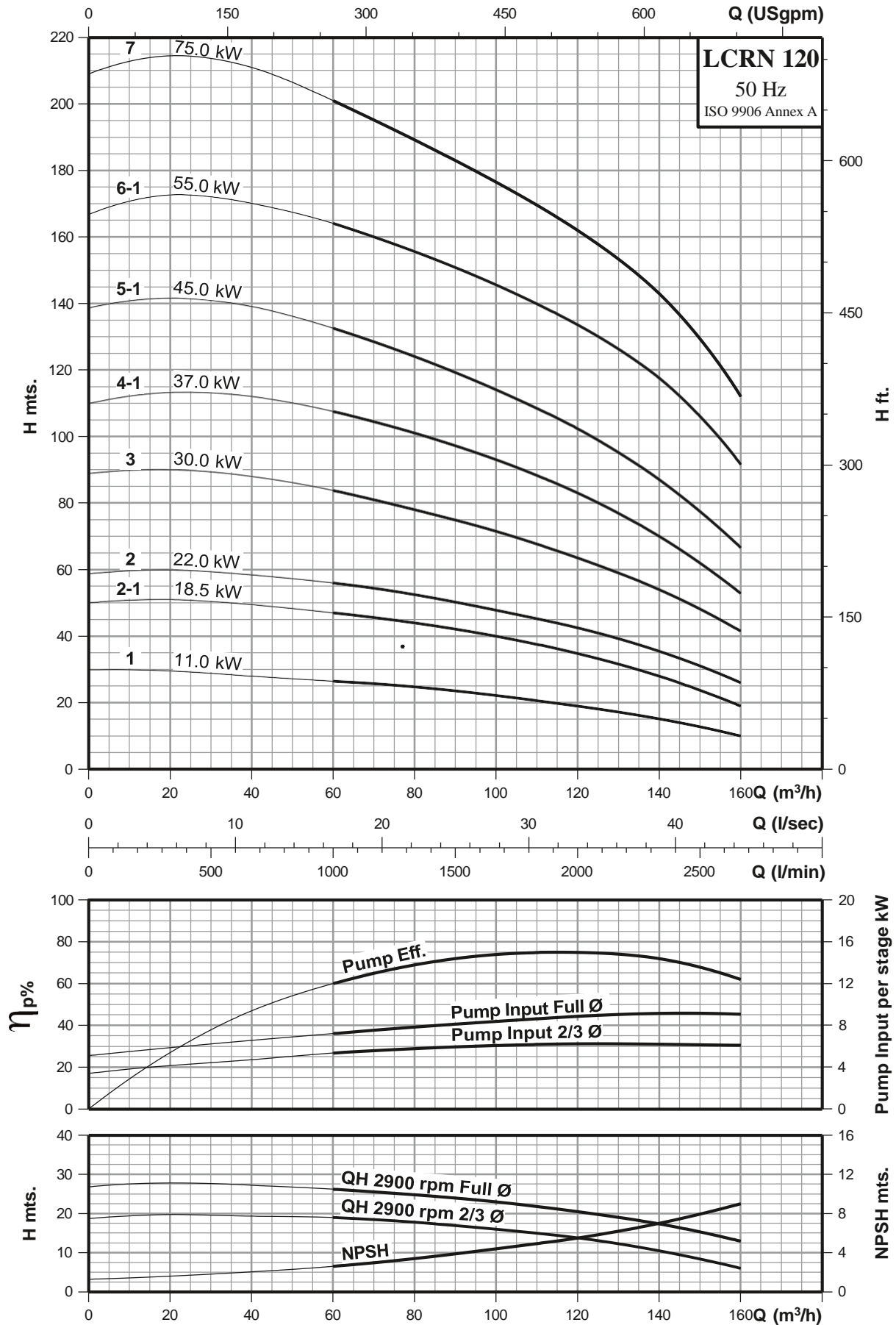

Technical Data

Vertical multistage centrifugal pumps

LCR 150

Performance Chart

Pump Type	H.P.	kW	Q l/min m ³ /h	n = 2900 rpm					
				1666.7	2000.0	2333.4	2500.1	2666.7	3000.1
				100.0	120.0	140.0	150.0	160.0	180.0
LCR 150/1-1	15.0	11.0	H mts.	18	16	14	13	11	8
LCR 150/1	20.0	15.0		25	22	20	19	18	15
LCR 150/2-1	30.0	22.0		45	42	39	37	35	28
LCR 150/3-2	40.0	30.0		64	59	55	53	49	39
LCR 150/3	50.0	37.0		78	71	65	62	58	49
LCR 150/4-1	60.0	45.0		97	90	84	81	78	64
LCR 150/5-2	75.0	55.0		119	110	102	98	93	80
LCR 150/6	100.0	75.0		163	152	143	138	134	121

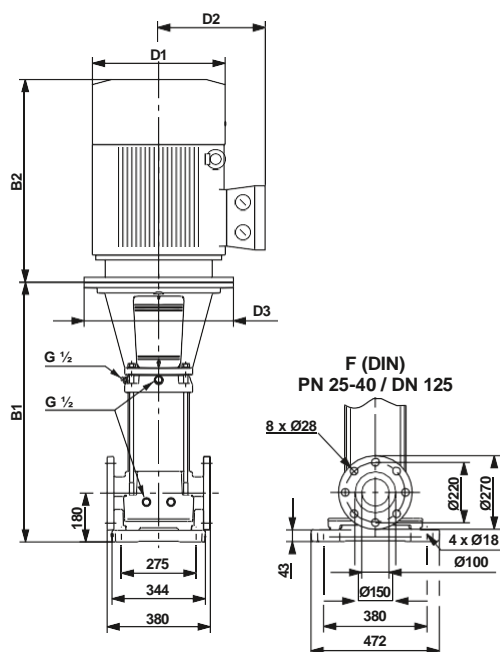

Dimensions & Weights of LCR Pump

Pump type	Dimensions [mm]					Net weight [kg]	Gross weight [kg]	Gross volume [m ³]
	DIN flange		D1	D2	D3			
	B1	B1+B2						
LCR 150/1-1	834	1376	304	225	350	191.0	291.0	0.2787
LCR 150/1	834	1376	304	225	350	204.0	304.0	0.2787
LCR 150/2-1	990	1600	363	262	350	241.0	361.0	0.5872
LCR 150/3-2	1145	1791	415	300	400	368.0	488.0	0.5872
LCR 150/3	1145	2004	415	300	400	383.0	503.0	0.5872
LCR 150/4-1	1301	2165	442	325	450	477.0	617.0	1.3716
LCR 150/5-2	1486	2284	493	414	550	617.0	757.0	1.3716
LCR 150/6	1642	2527	548	445	550	733.0	873.0	1.3716

Performance Curves

Vertical multistage centrifugal pumps

LCR 150

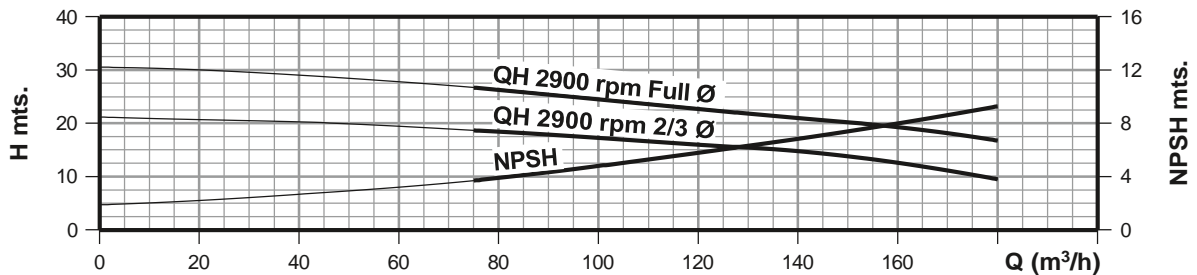
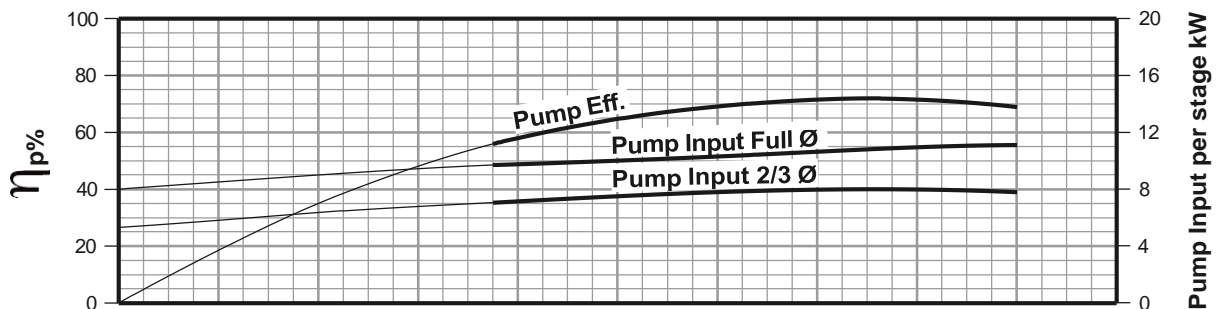
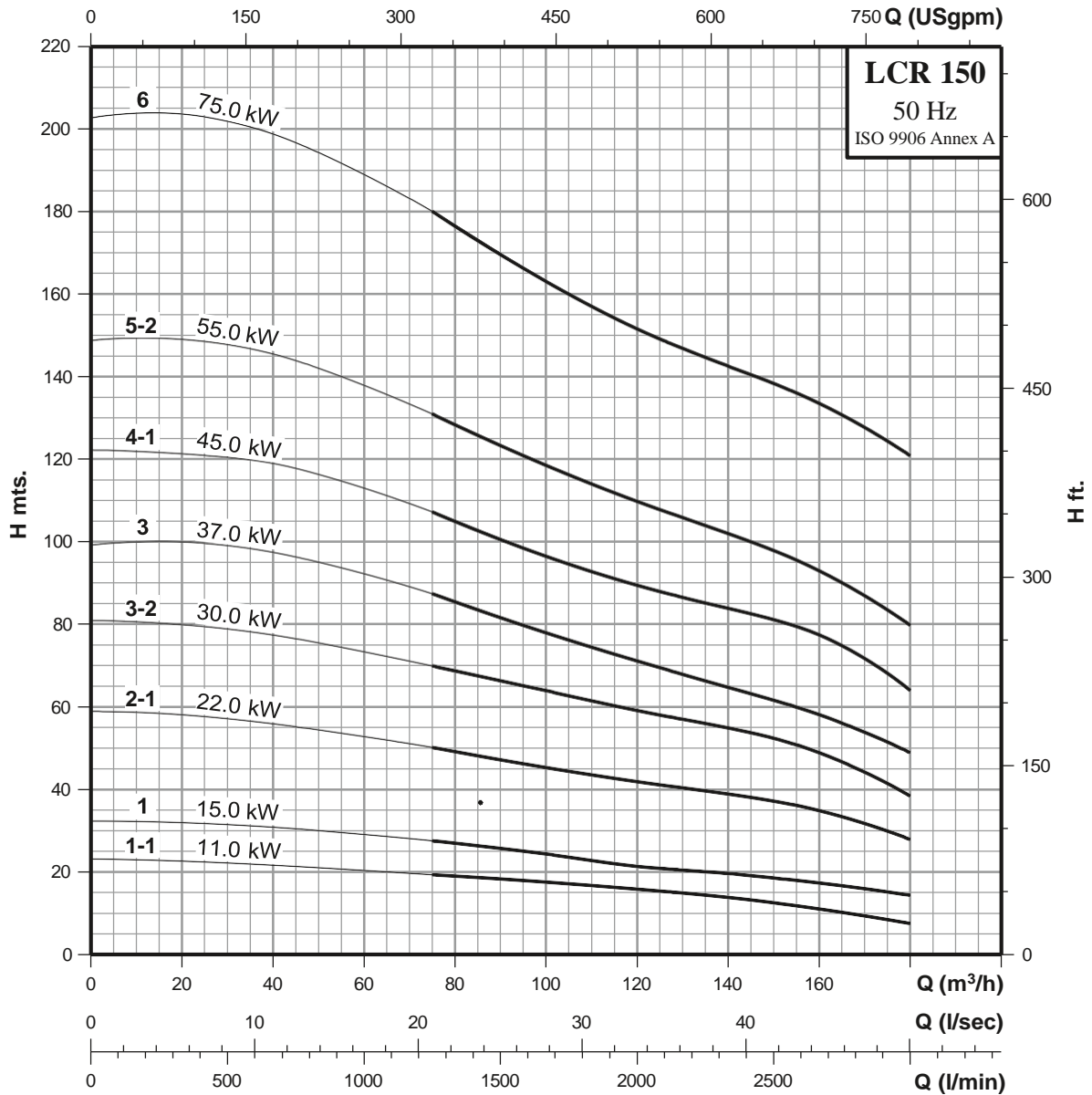

Technical Data

Vertical multistage centrifugal pumps

LCRN 150

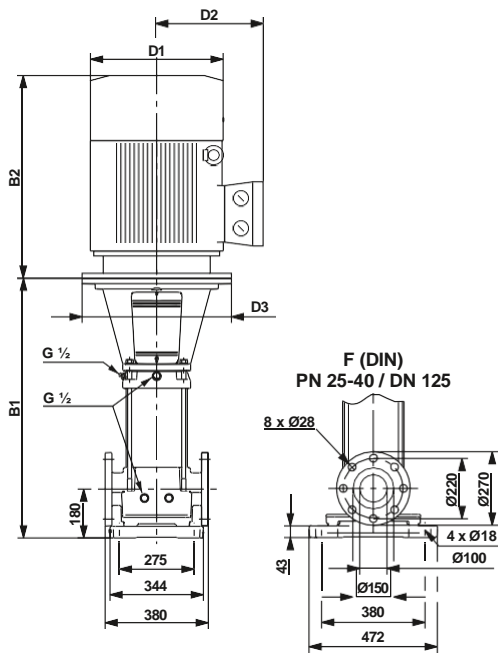

Pump Type	H.P.	kW	Q l/min m ³ /h	n = 2900 rpm					
				1666.7	2000.0	2333.4	2500.1	2666.7	3000.1
				100.0	120.0	140.0	150.0	160.0	180.0
LCRN 150/1-1	15.0	11.0	H mts.	18	16	14	13	11	8
LCRN 150/1	20.0	15.0		25	22	20	19	18	15
LCRN 150/2-1	30.0	22.0		45	42	39	37	35	28
LCRN 150/3-2	40.0	30.0		64	59	55	53	49	39
LCRN 150/3	50.0	37.0		78	71	65	62	58	49
LCRN 150/4-1	60.0	45.0		97	90	84	81	78	64
LCRN 150/5-2	75.0	55.0		119	110	102	98	93	80
LCRN 150/6	100.0	75.0		163	152	143	138	134	121

Dimensions & Weights of LCRN Pump

Pump type	Dimensions [mm]					Net weight [kg]	Gross weight [kg]	Gross volume [m ³]
	DIN flange		D1	D2	D3			
	B1	B1+B2						
LCRN 150/1-1	834	1376	304	225	350	191.0	291.0	0.2787
LCRN 150/1	834	1376	304	225	350	204.0	304.0	0.2787
LCRN 150/2-1	990	1600	363	262	350	241.0	361.0	0.5872
LCRN 150/3-2	1145	1791	415	300	400	368.0	488.0	0.5872
LCRN 150/3	1145	2004	415	300	400	383.0	503.0	0.5872
LCRN 150/4-1	1301	2165	442	325	450	477.0	617.0	1.3716
LCRN 150/5-2	1486	2284	493	414	550	617.0	757.0	1.3716
LCRN 150/6	1642	2527	548	445	550	733.0	873.0	1.3716

Performance Curves

Vertical multistage centrifugal pumps

LCRN 150

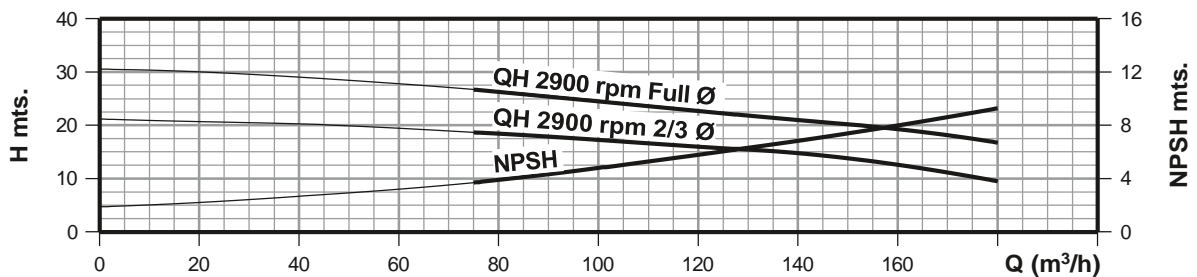
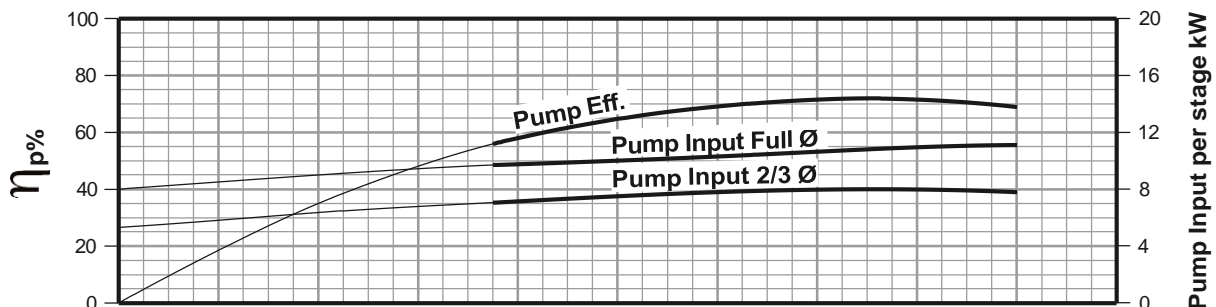
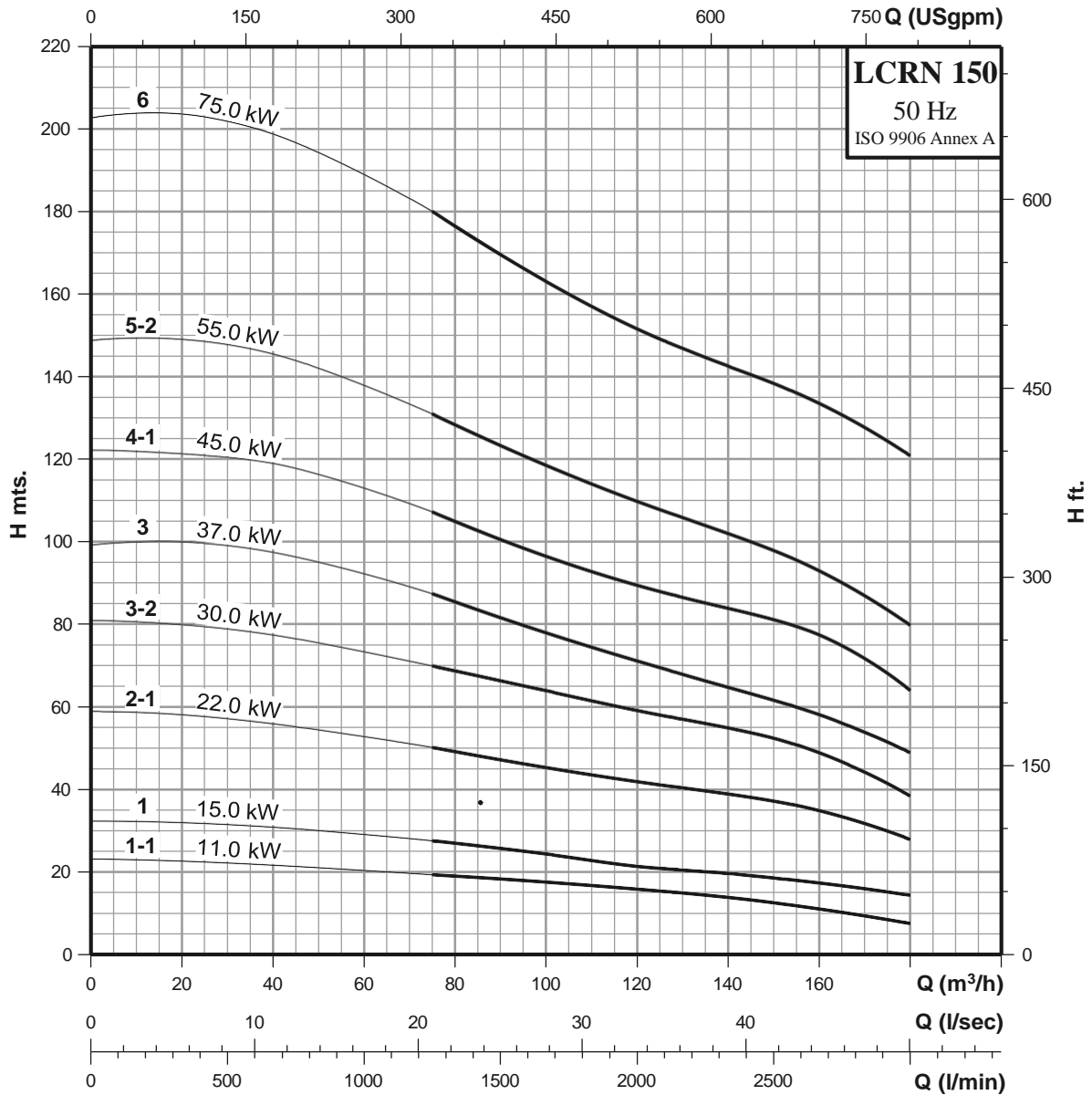

Available with Your Trusted Partner for Water Treatment Solutions:



Workshop: 14-15, Panchratna Industrial Estate, Opp Satyam Mall, Sumip Composite-3 Lane, B/h VR Pilsulfate, Changodar-382213

Office: B-214, Nilkanth Palace, 100 feet Anandnagar Road, Satelite, Ahmedabad-380015

Phone: 9227418504/7227061661 | Email: sales@fiplco.com | Website: www.fiplco.com