



THE ALL NEW
BOILER AUTO
DOSING SYSTEMS

MADE
IN
INDIA

BOILER FEED WATER CHEMICAL DOSING SYSTEMS

Boiler feed water, chemical need to be dosed and maintained at specific concentration for their desired effects to be achieved.

The object is to optimize the chemical dosing by employing our automatic chemical dosing system **OptiTherm** to achieve the best results.

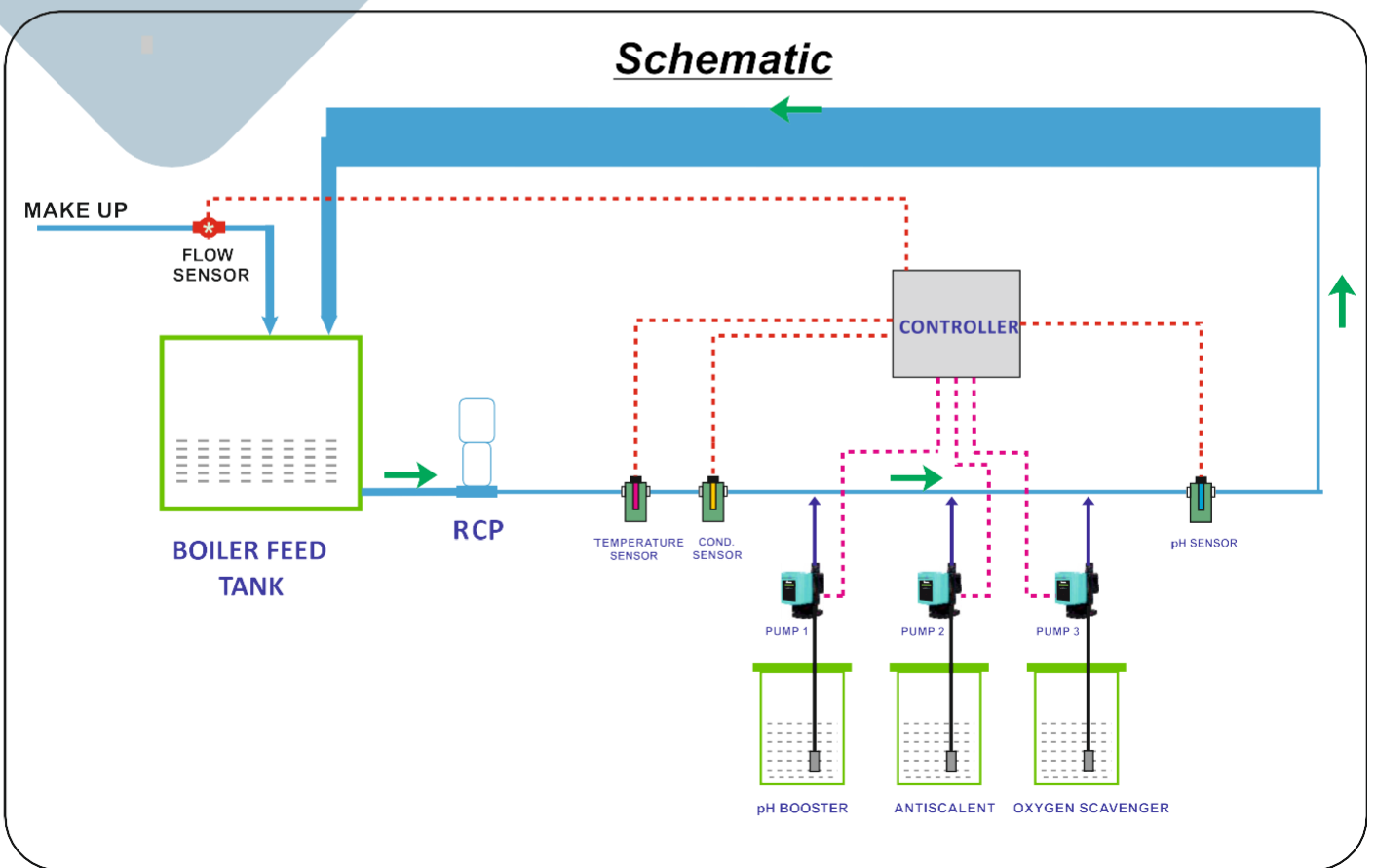

ADVANTAGES OF BOILER CHEMICAL DOSING SYSTEM

- TO PREVENT THE SCALE FORMATION IN THE BOILER AND FEED SYSTEM.
- TO PREVENT CORROSION IN BOILER AND FEED SYSTEM.
- TO MAINTAIN THE BOILER WATER IN ALKALINE CONDITION AND FREE FROM DISSOLVED GASES.
- TO REDUCE CHEMICAL HANDLING AND IMPROVE HEALTH AND SAFETY.



OPTION TO DOSE THREE CHEMICALS



AUTO/MANUAL SELECTION IS AVAILABLE



TEMPERATURE COMPENSATED READINGS FOR pH & CONDUCTIVITY



PROPORTIONAL/FUZZY CONTROL LOGIC FOR pH BOOSTER



DATA LOGGING VIA USB/RS485



TIME PROPORTIONAL DOSING

DIMENSIONS- 2230L X 820H X 350W



BRIGHT BACKLIT WITH LARGER DISPLAY

LOW LEVEL INTERLOCK

BACKLIT INDICATION FOR PUMP ON/OFF

KEYPAD LOCK FOR AVOIDING INTERFERENCE



LIVE DASHBOARD AND MIMIC

- Dashboard for live status of all parameters.
- MIMIC status of Running operation.

FUNCTION ALARM

- Facility to generate alarm on faulty condition and send notification or alert through email/SMS.
- Facility to export in to Excel sheet.

CHEMICAL CONSUMPTION AND AVAILABILITY

- Available with daily , weekly, monthly, yearly chemical consumption details.
- Chemical storage tanks level monitoring

STREAMLINE MAINTENANCE

- It's of critical importance that all systems, programs and applications are well-maintained and kept up-to-date with overall health checks. Remote monitoring keeps track of the status of all of your technology to ensure that any issues that arise are promptly addressed.

MAINTENANCE ALERT

- having facility to generate maintenance alert for technician through Email.
- Reminder for sensor calibration

Available with Your Trusted Partner for Water Treatment Solutions:

